

Protocol for Selective Activation of GABA-C Receptors Using CACA

Author: BenchChem Technical Support Team. **Date:** December 2025

Compound of Interest

Compound Name: 4-Aminocrotonic acid

Cat. No.: B3425015

[Get Quote](#)

For Researchers, Scientists, and Drug Development Professionals

Application Notes and Protocols for Utilizing cis-4-aminocrotonic acid (CACA) as a Selective Agonist for Gamma-Aminobutyric Acid Type C (GABA-C) Receptors

This document provides a comprehensive guide for the use of cis-4-aminocrotonic acid (CACA), a conformationally restricted analog of the neurotransmitter gamma-aminobutyric acid (GABA), to selectively activate GABA-C receptors. GABA-C receptors, a subtype of ionotropic GABA receptors, are ligand-gated chloride channels.[1] Their distinct pharmacology and localization in the central nervous system, particularly the retina, make them a target of interest for neuroscience research and drug development.

CACA serves as a potent and selective partial agonist for GABA-C receptors, exhibiting minimal to no activity at GABA-A and GABA-B receptors.[2] This selectivity allows for the precise investigation of GABA-C receptor function and the screening of novel therapeutic agents targeting this receptor subtype.

Data Presentation: Quantitative Comparison of CACA Activity at GABA Receptor Subtypes

The following table summarizes the quantitative data on the potency and affinity of CACA at GABA-A, GABA-B, and GABA-C receptors. The data highlights the selectivity of CACA for the GABA-C receptor subtype.

Receptor Subtype	Ligand	Parameter	Value (μM)	Notes
GABA-C	CACA	EC50	~1	Highly sensitive to CACA.[3]
GABA-A	CACA	Affinity (Kd)	>1000	CACA does not significantly bind to GABA-A receptors.
GABA-B	CACA	Affinity (Kd)	>1000	CACA does not significantly bind to GABA-B receptors.

Experimental Protocols

I. Preparation of *Xenopus laevis* Oocytes for GABA-C Receptor Expression

This protocol describes the preparation of *Xenopus laevis* oocytes for the expression of GABA-C receptors, a common system for studying ion channel function.

Materials:

- Mature female *Xenopus laevis*
- Collagenase solution (e.g., 2 mg/mL in calcium-free oocyte Ringer's solution)
- Calcium-free oocyte Ringer's (OR-2) solution: 82.5 mM NaCl, 2.5 mM KCl, 1 mM MgCl₂, 5 mM HEPES, pH 7.5

- Oocyte Ringer's (ND96) solution: 96 mM NaCl, 2 mM KCl, 1.8 mM CaCl₂, 1 mM MgCl₂, 5 mM HEPES, pH 7.5
- cRNA encoding the desired GABA-C receptor subunit (e.g., $\rho 1$)

Procedure:

- Surgically remove a portion of the ovary from an anesthetized *Xenopus laevis*.
- Isolate oocytes by gentle dissection.
- Treat the oocytes with collagenase solution for 1-2 hours at room temperature with gentle agitation to defolliculate.
- Wash the oocytes thoroughly with calcium-free OR-2 solution.
- Select healthy, stage V-VI oocytes.
- Inject each oocyte with 50 nL of GABA-C receptor subunit cRNA (e.g., 0.1-1 ng/oocyte).
- Incubate the injected oocytes in ND96 solution supplemented with antibiotics at 16-18°C for 2-7 days to allow for receptor expression.

II. Two-Electrode Voltage Clamp (TEVC) Electrophysiology for Measuring CACA-induced Currents

This protocol details the use of two-electrode voltage clamp electrophysiology to record the currents elicited by the application of CACA to GABA-C receptor-expressing *Xenopus* oocytes.

Materials:

- GABA-C receptor-expressing *Xenopus* oocytes
- Two-electrode voltage clamp amplifier and data acquisition system
- Glass microelectrodes (0.5-2 M Ω resistance) filled with 3 M KCl

- Recording chamber
- Perfusion system
- ND96 solution (as the external recording solution)
- CACA stock solution (e.g., 100 mM in water) and serial dilutions in ND96

Procedure:

- Place a GABA-C receptor-expressing oocyte in the recording chamber and continuously perfuse with ND96 solution.
- Impale the oocyte with two microelectrodes, one for voltage clamping and the other for current recording.
- Clamp the oocyte membrane potential at a holding potential of -70 mV.
- Establish a stable baseline current recording.
- Apply increasing concentrations of CACA to the oocyte via the perfusion system, with washout periods in between applications to allow for receptor recovery.
- Record the inward chloride current elicited by CACA at each concentration.
- Construct a dose-response curve by plotting the peak current amplitude against the CACA concentration to determine the EC50 value.

Mandatory Visualizations

GABA-C Receptor Signaling Pathway

The activation of GABA-C receptors by CACA leads to the opening of an integrated chloride ion channel. This results in an influx of chloride ions into the neuron, causing hyperpolarization of the cell membrane and subsequent inhibition of neuronal excitability.

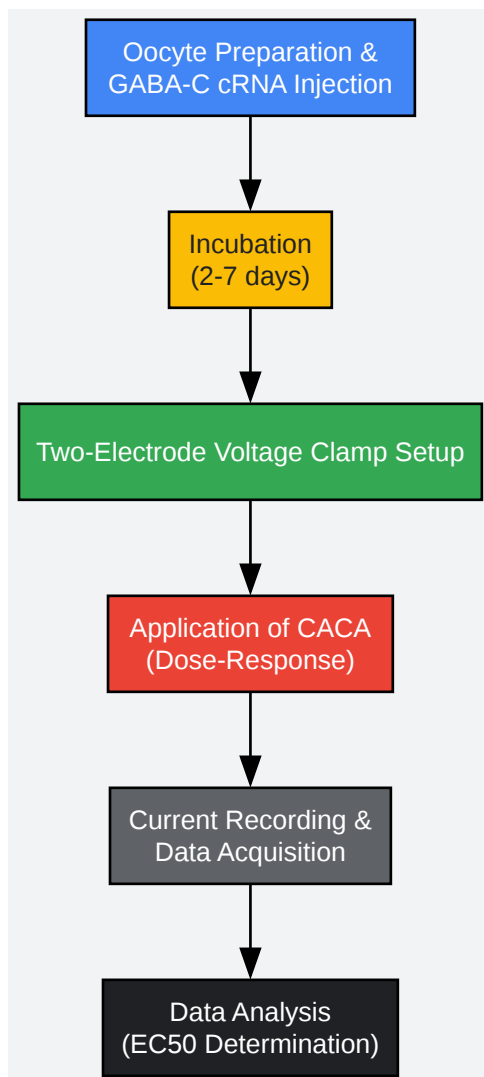
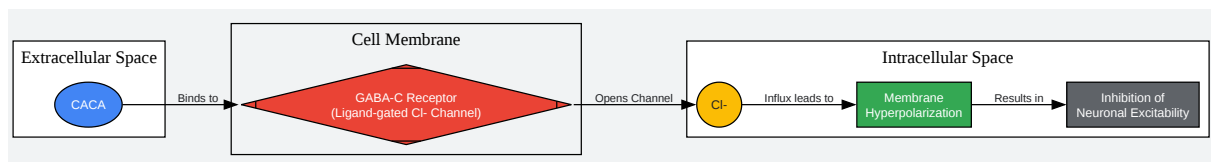

[Click to download full resolution via product page](#)

Need Custom Synthesis?

BenchChem offers custom synthesis for rare earth carbides and specific isotopic labeling.

Email: info@benchchem.com or [Request Quote Online](#).

References

- 1. youtube.com [youtube.com]
- 2. researchgate.net [researchgate.net]
- 3. GABAC Receptors [sigmaaldrich.com]
- To cite this document: BenchChem. [Protocol for Selective Activation of GABA-C Receptors Using CACA]. BenchChem, [2025]. [Online PDF]. Available at: [https://www.benchchem.com/product/b3425015#protocol-for-using-caca-to-selectively-activate-gabac-receptors]

Disclaimer & Data Validity:

The information provided in this document is for Research Use Only (RUO) and is strictly not intended for diagnostic or therapeutic procedures. While BenchChem strives to provide accurate protocols, we make no warranties, express or implied, regarding the fitness of this product for every specific experimental setup.

Technical Support: The protocols provided are for reference purposes. Unsure if this reagent suits your experiment? [[Contact our Ph.D. Support Team for a compatibility check](#)]

Need Industrial/Bulk Grade? [Request Custom Synthesis Quote](#)

BenchChem

Our mission is to be the trusted global source of essential and advanced chemicals, empowering scientists and researchers to drive progress in science and industry.

Contact

Address: 3281 E Guasti Rd
Ontario, CA 91761, United States
Phone: (601) 213-4426
Email: info@benchchem.com