

Introduction: The 6-Hydroxy-4H-Chromen-4-one Scaffold as a Privileged Structure

Author: BenchChem Technical Support Team. **Date:** April 2026

Compound of Interest

Compound Name: 6-hydroxy-4H-chromen-4-one

CAS No.: 38445-24-8

Cat. No.: B3425073

[Get Quote](#)

The 4H-chromen-4-one (chromone) framework is a cornerstone in medicinal chemistry and natural product synthesis, with derivatives exhibiting a vast spectrum of biological activities. The strategic placement of a hydroxyl group at the C-6 position offers a versatile synthetic handle for molecular elaboration. Derivatization of this phenolic hydroxyl group is a critical strategy for modulating the physicochemical and pharmacological properties of the parent molecule. By converting the hydroxyl group into ethers, esters, or glycosides, researchers can fine-tune parameters such as lipophilicity, metabolic stability, aqueous solubility, and receptor-binding interactions. This guide provides a detailed overview of the primary synthetic techniques for derivatizing the **6-hydroxy-4H-chromen-4-one** core, complete with mechanistic insights and actionable laboratory protocols.

Core Derivatization Strategies

The derivatization of the 6-hydroxyl function primarily involves three robust and well-established classes of organic reactions: O-alkylation to form ethers, O-acylation to generate esters, and the Mitsunobu reaction for a range of functional group interconversions.

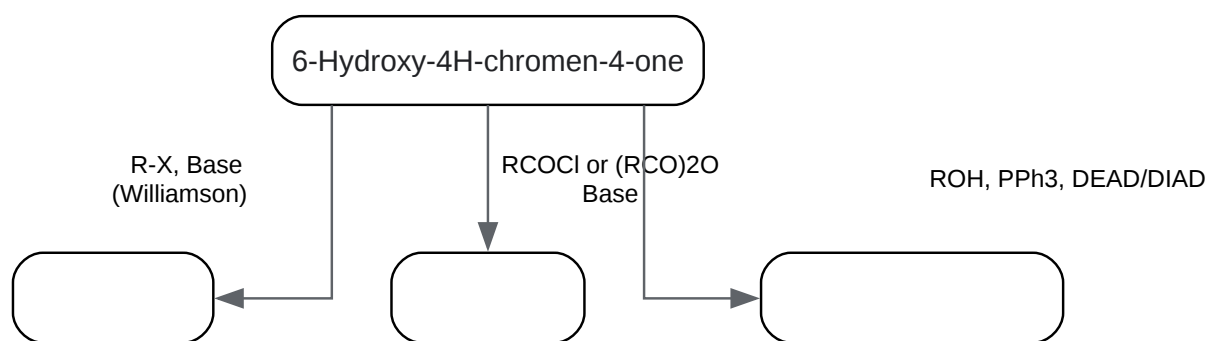

[Click to download full resolution via product page](#)

Caption: Key derivatization pathways for **6-hydroxy-4H-chromen-4-one**.

O-Alkylation: The Williamson Ether Synthesis

The Williamson ether synthesis is the most fundamental and widely applied method for preparing aryl ethers. The reaction proceeds via a bimolecular nucleophilic substitution (S_N2) mechanism.^{[1][2]}

Mechanistic Rationale: The reaction is initiated by the deprotonation of the weakly acidic phenolic hydroxyl group using a suitable base to form a potent nucleophile, the phenoxide anion. This anion then attacks the electrophilic carbon of an alkyl halide (or other alkylating agent with a good leaving group, like a tosylate), displacing the leaving group and forming the ether bond.^{[1][3]}

Causality in Experimental Design:

- **Choice of Base:** The pK_a of a phenol is approximately 10. Therefore, a base strong enough to deprotonate it is required. While strong bases like sodium hydride (NaH) are effective, milder bases such as potassium carbonate (K₂CO₃) or cesium carbonate (Cs₂CO₃) are often preferred for their ease of handling and are particularly effective in polar aprotic solvents.^[3]
- **Alkylating Agent:** The S_N2 mechanism is highly sensitive to steric hindrance.^[2] Therefore, primary alkyl halides are the ideal substrates. Secondary halides may give a mixture of substitution and elimination products, while tertiary halides will almost exclusively yield the elimination product (alkene).^{[2][3]}

- Solvent Selection: Polar aprotic solvents like dimethylformamide (DMF), dimethyl sulfoxide (DMSO), or acetonitrile are optimal.[3][4] These solvents solvate the cation of the base, leaving a more reactive, "naked" phenoxide anion, which significantly accelerates the rate of substitution.[2]

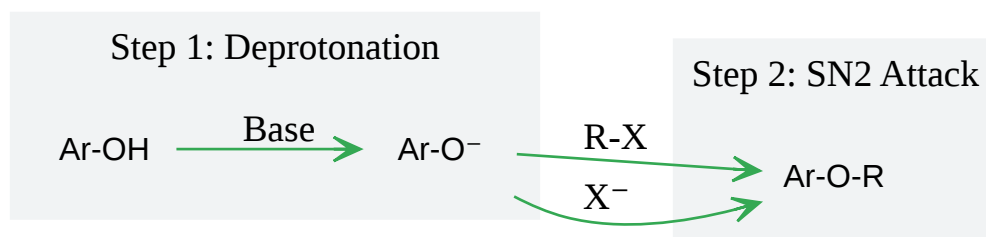

[Click to download full resolution via product page](#)

Caption: Mechanism of the Williamson Ether Synthesis.

Protocol 1: General Procedure for O-Alkylation of 6-Hydroxy-4H-chromen-4-one

This protocol is adapted from general procedures for the O-alkylation of phenolic compounds.
[5][6]

Materials and Reagents:

- **6-Hydroxy-4H-chromen-4-one**
- Alkyl halide (e.g., iodomethane, benzyl bromide) (1.2 equivalents)
- Potassium carbonate (K₂CO₃), anhydrous (1.5 equivalents)
- Dimethylformamide (DMF), anhydrous
- Dichloromethane (DCM)
- Water
- Brine (saturated NaCl solution)

- Anhydrous sodium sulfate (Na_2SO_4) or magnesium sulfate (MgSO_4)
- Round-bottom flask, magnetic stirrer, condenser, and standard glassware

Procedure:

- To a round-bottom flask under an inert atmosphere (e.g., nitrogen or argon), add **6-hydroxy-4H-chromen-4-one** (1.0 eq) and anhydrous potassium carbonate (1.5 eq).
- Add anhydrous DMF to dissolve/suspend the solids (a concentration of ~ 0.1 M is typical).
- Stir the suspension at room temperature for 15-20 minutes to facilitate phenoxide formation.
- Add the alkyl halide (1.2 eq) dropwise to the stirring suspension.
- Heat the reaction mixture to a temperature between 50-80 °C. The optimal temperature may vary depending on the reactivity of the alkyl halide.
- Monitor the reaction progress by Thin Layer Chromatography (TLC) until the starting material is consumed (typically 4-24 hours).
- After completion, cool the reaction to room temperature and pour it into a separatory funnel containing water.
- Extract the aqueous layer with dichloromethane (3 x volume of DMF).
- Combine the organic layers and wash with water, followed by brine.
- Dry the organic phase over anhydrous Na_2SO_4 , filter, and concentrate under reduced pressure.
- Purify the crude product by flash column chromatography (e.g., using a hexane/ethyl acetate gradient) to yield the desired 6-alkoxy-4H-chromen-4-one derivative.

O-Acylation: Ester Synthesis

The formation of esters from the 6-hydroxyl group is readily achieved by reaction with an acylating agent, such as an acyl chloride or a carboxylic anhydride.

Mechanistic Rationale: This reaction is a nucleophilic acyl substitution. The phenolic oxygen attacks the electrophilic carbonyl carbon of the acylating agent. In the case of acyl chlorides, a tetrahedral intermediate is formed, which then collapses, expelling a chloride ion. A base is required to neutralize the HCl byproduct, which would otherwise protonate the starting phenol, deactivating it.[7]

Causality in Experimental Design:

- **Acylating Agent:** Both acyl chlorides and anhydrides are highly effective. Acyl chlorides are generally more reactive.
- **Base:** A non-nucleophilic organic base like pyridine or triethylamine (TEA) is commonly used. Pyridine can also act as a nucleophilic catalyst. In the Schotten-Baumann reaction, an aqueous base like NaOH is used in a two-phase system.[7]
- **Phase-Transfer Catalysis (PTC):** For biphasic systems, a phase-transfer catalyst (e.g., tetrabutylammonium chloride) can be employed to shuttle the phenoxide anion from the aqueous phase to the organic phase containing the acyl chloride, dramatically increasing reaction rates and yields.[7] This method is efficient, often complete in minutes at 0°C, and avoids the need for anhydrous conditions.[7]

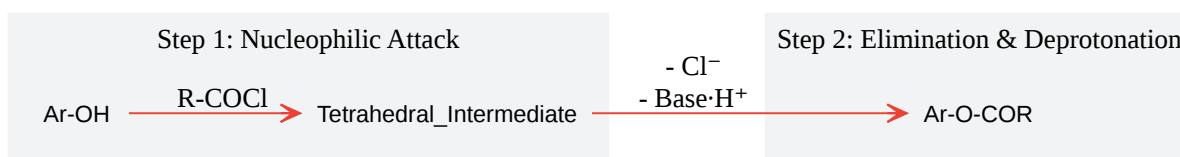

[Click to download full resolution via product page](#)

Caption: Mechanism of O-Acylation with an Acyl Chloride.

Protocol 2: General Procedure for O-Acylation using an Acyl Chloride

Materials and Reagents:

- **6-Hydroxy-4H-chromen-4-one**
- Acyl chloride (e.g., acetyl chloride, benzoyl chloride) (1.1 equivalents)
- Pyridine or Triethylamine (TEA) (1.5-2.0 equivalents)
- Dichloromethane (DCM) or Tetrahydrofuran (THF), anhydrous
- 1 M Hydrochloric acid (HCl)
- Saturated sodium bicarbonate (NaHCO₃) solution
- Brine, water, and anhydrous Na₂SO₄

Procedure:

- Dissolve **6-hydroxy-4H-chromen-4-one** (1.0 eq) in anhydrous DCM in a round-bottom flask under an inert atmosphere.
- Cool the solution to 0 °C using an ice bath.
- Add the base (pyridine or TEA, 1.5 eq) to the solution.
- Add the acyl chloride (1.1 eq) dropwise with vigorous stirring. A precipitate (pyridinium or triethylammonium hydrochloride) may form.
- Allow the reaction to warm to room temperature and stir for 2-16 hours, monitoring by TLC.
- Upon completion, dilute the reaction mixture with DCM.
- Wash the organic layer sequentially with water, 1 M HCl (to remove excess base), saturated NaHCO₃ solution (to remove any remaining acid), and finally brine.
- Dry the organic phase over anhydrous Na₂SO₄, filter, and concentrate under reduced pressure.
- Purify the crude product by flash column chromatography or recrystallization to obtain the pure 6-acyloxy-4H-chromen-4-one.

The Mitsunobu Reaction: A Versatile Alternative

The Mitsunobu reaction is a powerful tool for converting alcohols into a wide array of functional groups, including esters and ethers, under mild, neutral conditions.^{[8][9]} A key feature of this reaction is that it proceeds with a complete inversion of stereochemistry at the alcohol carbon, though this is not relevant for a planar phenol.^{[9][10]}

Mechanistic Rationale: The reaction begins with the nucleophilic attack of triphenylphosphine (PPh_3) on an azodicarboxylate, typically diethyl azodicarboxylate (DEAD) or diisopropyl azodicarboxylate (DIAD), to form a betaine intermediate.^{[9][10]} This intermediate deprotonates the acidic nucleophile (e.g., a carboxylic acid for esterification) and the alcohol (the 6-hydroxyl group) to form an alkoxyphosphonium salt. This salt activates the hydroxyl group, turning it into an excellent leaving group. Finally, the conjugate base of the acidic nucleophile performs an $\text{S}_{\text{N}}2$ displacement on the carbon, yielding the product, triphenylphosphine oxide (TPPO), and a hydrazine byproduct.^[10]

Causality in Experimental Design:

- **Order of Addition:** The order of reagent addition can be critical. Typically, the alcohol, nucleophile (e.g., carboxylic acid), and PPh_3 are dissolved first, and the DEAD is added dropwise at a low temperature ($0\text{ }^\circ\text{C}$).^{[9][11]} This controls the initial exothermic reaction and prevents side reactions.
- **Nucleophile Acidity:** The nucleophile should be sufficiently acidic ($\text{pK}_\text{a} < 13$) to be deprotonated by the betaine intermediate.^[9] This prevents the azodicarboxylate itself from acting as the nucleophile.
- **Workup:** A major challenge of the Mitsunobu reaction is the removal of byproducts, particularly triphenylphosphine oxide (TPPO). Purification often requires careful chromatography.

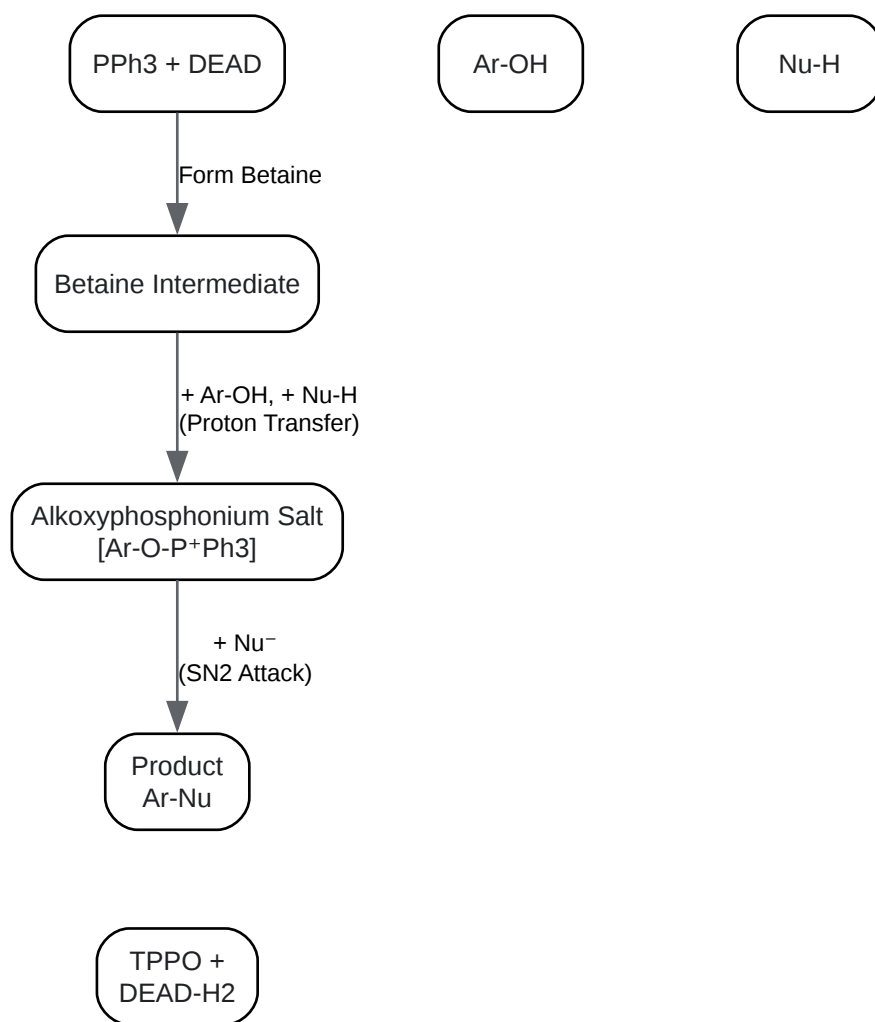

[Click to download full resolution via product page](#)

Caption: Simplified workflow of the Mitsunobu Reaction.

Protocol 3: General Procedure for Mitsunobu Esterification

Materials and Reagents:

- **6-Hydroxy-4H-chromen-4-one** (1.0 eq)
- Carboxylic acid (1.2-1.5 eq)
- Triphenylphosphine (PPh₃) (1.5 eq)

- Diethyl azodicarboxylate (DEAD) or Diisopropyl azodicarboxylate (DIAD) (1.5 eq), typically as a 40% solution in toluene
- Tetrahydrofuran (THF), anhydrous
- Standard workup and purification reagents

Procedure:

- In a flame-dried, round-bottom flask under an inert atmosphere, dissolve **6-hydroxy-4H-chromen-4-one** (1.0 eq), the carboxylic acid (1.2 eq), and triphenylphosphine (1.5 eq) in anhydrous THF.
- Cool the solution to 0 °C in an ice bath.
- Slowly add the DEAD or DIAD solution (1.5 eq) dropwise via syringe over 10-15 minutes. The solution may turn from colorless to a yellow or orange hue.
- Allow the reaction to stir at 0 °C for 30 minutes, then warm to room temperature.
- Monitor the reaction by TLC. The reaction is often complete within 2-8 hours. The formation of a white precipitate (TPPO) is an indication of reaction progress.^[11]
- Once complete, remove the solvent under reduced pressure.
- The crude residue can be directly purified by flash column chromatography. Eluting with a non-polar solvent first can help remove some non-polar byproducts before eluting the desired ester product.

Comparative Summary of Derivatization Techniques

| Technique | Key Reagents | Advantages | Disadvantages | Best For |
|-----------------------------|---------------------------------------|--|---|--|
| Williamson Ether Synthesis | Base (K_2CO_3 , NaH), Alkyl Halide | Robust, scalable, widely applicable. | Requires strong base, limited to primary/methyl halides, can require heat. | Simple ether synthesis. ^{[1][2]} |
| O-Acylation (Acyl Chloride) | Acyl Chloride, Base (Pyridine, TEA) | Fast, high-yielding, uses common reagents. | Generates acidic byproduct, requires anhydrous conditions. | Straightforward ester synthesis. |
| Mitsunobu Reaction | PPh_3 , DEAD/DIAD, Nucleophile | Very mild, neutral conditions, wide substrate scope. | Stoichiometric byproducts (TPPO) can complicate purification. ^[10] | Ester or ether formation when other methods fail or when using sensitive substrates. |

Conclusion

The derivatization of the 6-hydroxyl group of 4H-chromen-4-one is a pivotal step in the synthesis of novel analogues for drug discovery and chemical biology. The choice of synthetic method—be it the classic Williamson ether synthesis, a straightforward acylation, or the versatile Mitsunobu reaction—should be guided by the desired final product, the availability of reagents, and the chemical tolerances of the substrate. By understanding the mechanistic underpinnings of each technique, researchers can make informed decisions to optimize reaction conditions and achieve their synthetic goals efficiently.

References

- Psotová, J., Lasovský, J., & Vicar, J. (2003). Phase-transfer catalytic determination of phenols as methylated derivatives by gas chromatography with flame ionization and mass-selective detection. *Journal of Chromatography A*, 983(1-2), 215-23. Available at: [\[Link\]](#)

- Jadhav, S. A., & Ganvir, V. N. (2014). Phase transfer catalysed esterification of phenols with aliphatic acid chlorides. *International Journal of Research in Engineering and Technology*, 3(2), 481-484.
- Kim, J. K., & Lee, J. W. (2009). O-ACYLATION MECHANISM OF p-SUBSTITUTED PHENOLS WITH VARIOUS ALKANOYL CHLORIDES UNDER PHASE TRANSFER CATALYSIS CONDITIONS. *Journal of the Korean Chemical Society*, 53(4), 453-457.
- Halpern, M. (n.d.). PTC Etherification of a Phenol. PTC Organics, Inc. Retrieved from [\[Link\]](#)
- Li, T., et al. (2023). Enantioselective Dearomatization of Substituted Phenols via Organocatalyzed Electrophilic Amination. *Organic Letters*, 25(32), 5964-5969. Available at: [\[Link\]](#)
- Cambridge University Press. (n.d.). Williamson Ether Synthesis. In *Name Reactions in Organic Synthesis*. Available at: [\[Link\]](#)
- Kumar, P., & Bodas, M. S. (2000). A Novel Synthesis of 4H-Chromen-4-ones via Intramolecular Wittig Reaction. *Organic Letters*, 2(24), 3821–3823. Available at: [\[Link\]](#)
- Wikipedia. (n.d.). Mitsunobu reaction. Retrieved from [\[Link\]](#)
- O'Meara, J. A., et al. (2012). Synthesis and Evaluation of Substituted Chroman-4-one and Chromone Derivatives as Sirtuin 2-Selective Inhibitors. *Journal of Medicinal Chemistry*, 55(14), 6482–6500. Available at: [\[Link\]](#)
- Santos, C. M. M., & Silva, A. M. S. (2022). Recent advances in the synthesis of 4H-chromen-4-ones (2012–2021). In *Advances in Heterocyclic Chemistry* (Vol. 136, pp. 159-241). Elsevier.
- Wikipedia. (n.d.). Williamson ether synthesis. Retrieved from [\[Link\]](#)
- Organic Chemistry Portal. (n.d.). Mitsunobu Reaction. Retrieved from [\[Link\]](#)
- Organic Synthesis. (n.d.). Mitsunobu reaction. Retrieved from [\[Link\]](#)
- Fletcher, S. P. (2015).
- Kumar, P., & Bodas, M. S. (2000). A Novel Synthesis of 4H-Chromen-4-ones via Intramolecular Wittig Reaction. *Organic Letters*, 2(24), 3821–3823. Available at: [\[Link\]](#)

- de Oliveira, C. A., et al. (2023). Synthesis and Antimicrobial Evaluation of Chroman-4-One and Homoisoflavonoid Derivatives. *Molecules*, 28(14), 5543. Available at: [\[Link\]](#)
- Ashenhurst, J. (2014). The Williamson Ether Synthesis. *Master Organic Chemistry*. Retrieved from [\[Link\]](#)
- Li, J., et al. (2023).
- O'Meara, J. A., et al. (2012). Synthesis and Evaluation of Substituted Chroman-4-one and Chromone Derivatives as Sirtuin 2-Selective Inhibitors. *Journal of Medicinal Chemistry*, 55(14), 6482-6500. Available at: [\[Link\]](#)
- Escrig-Doménech, A., Simó-Alfonso, E. F., & Ramis-Ramos, G. (2013). Derivatization of hydroxyl functional groups for liquid chromatography and capillary electroseparation. *Journal of Chromatography A*, 1296, 1-20. Available at: [\[Link\]](#)
- Regis Technologies. (n.d.). GC Derivatization. Retrieved from [\[Link\]](#)
- Escrig-Doménech, A., Simó-Alfonso, E., & Ramis-Ramos, G. (2013). Derivatization of hydroxyl functional groups for liquid chromatography and capillary electroseparation. *Journal of Chromatography A*, 1296, 1-20. Available at: [\[Link\]](#)
- Escrig-Doménech, A., Simó-Alfonso, E., & Ramis-Ramos, G. (2013). Derivatization of hydroxyl functional groups for liquid chromatography and capillary electroseparation. *Journal of Chromatography A*, 1296, 1-20. Available at: [\[Link\]](#)
- PubChem. (n.d.). 6-hydroxy-2-methyl-4h-chromen-4-one. Retrieved from [\[Link\]](#)
- ResearchGate. (n.d.). Synthesis of chromen-4-one ester 5 a. Retrieved from [\[Link\]](#)
- Deuther-Conrad, W., et al. (2021). Studies on the affinity of 6-[(n-(cyclo)aminoalkyl)oxy]-4 H-chromen-4-ones for sigma 1/2 receptors. *RSC Medicinal Chemistry*, 12(6), 1000-1004. Available at: [\[Link\]](#)
- Deuther-Conrad, W., et al. (2021). Studies on the affinity of 6-[(n-(cyclo)aminoalkyl)oxy]-4H-chromen-4-ones for sigma 1/2 receptors. *RSC Medicinal Chemistry*, 12(6), 1000-1004. Available at: [\[Link\]](#)

- Bouziane, A., et al. (2020). Review on 4-Hydroxycoumarin Chemistry: Synthesis, Acylation and Photochemical Properties. World Journal of Organic Chemistry, 8(1), 1-13. Available at: [\[Link\]](#)
- Royal Society of Chemistry. (n.d.). Organic & Biomolecular Chemistry. Retrieved from [\[Link\]](#)
- Royal Society of Chemistry. (n.d.). Facile construction of densely functionalized 4H-chromenes via three-component reactions catalyzed by L-proline. Green Chemistry. Retrieved from [\[Link\]](#)
- AA Blocks. (n.d.). 4H-Chromen-4-one. Retrieved from [\[Link\]](#)
- Ashenhurst, J. (2022). Fischer Esterification. Master Organic Chemistry. Retrieved from [\[Link\]](#)
- Zhao, L., et al. (2019). Discovery of 4 H-Chromen-4-one Derivatives as a New Class of Selective Rho Kinase (ROCK) Inhibitors, which Showed Potent Activity in ex Vivo Diabetic Retinopathy Models. Journal of Medicinal Chemistry, 62(23), 10691-10710. Available at: [\[Link\]](#)
- de Oliveira, C. A., et al. (2023). Synthesis and Antimicrobial Evaluation of Chroman-4-One and Homoisoflavonoid Derivatives. Molecules, 28(14), 5543. Available at: [\[Link\]](#)
- The Organic Chemistry Tutor. (2019, January 15). Mechanism of ester hydrolysis. YouTube. Retrieved from [\[Link\]](#)
- Zhang, Y., et al. (2021). Deciphering the O-Glycosylation of HKU1 Spike Protein With the Dual-Functional Hydrophilic Interaction Chromatography Materials. Frontiers in Chemistry, 9, 709653. Available at: [\[Link\]](#)

Need Custom Synthesis?

BenchChem offers custom synthesis for rare earth carbides and specific isotopic labeling.

Email: info@benchchem.com or [Request Quote Online](#).

Sources

- [1. Williamson ether synthesis - Wikipedia \[en.wikipedia.org\]](#)
- [2. masterorganicchemistry.com \[masterorganicchemistry.com\]](#)
- [3. jk-sci.com \[jk-sci.com\]](#)
- [4. Williamson Ether Synthesis \(Chapter 116\) - Name Reactions in Organic Synthesis \[cambridge.org\]](#)
- [5. Synthesis and Antimicrobial Evaluation of Chroman-4-One and Homoisoflavonoid Derivatives - PMC \[pmc.ncbi.nlm.nih.gov\]](#)
- [6. mdpi.com \[mdpi.com\]](#)
- [7. revroum.lew.ro \[revroum.lew.ro\]](#)
- [8. alfa-chemistry.com \[alfa-chemistry.com\]](#)
- [9. Mitsunobu reaction - Wikipedia \[en.wikipedia.org\]](#)
- [10. Mitsunobu Reaction \[organic-chemistry.org\]](#)
- [11. organic-synthesis.com \[organic-synthesis.com\]](#)
- [To cite this document: BenchChem. \[Introduction: The 6-Hydroxy-4H-Chromen-4-one Scaffold as a Privileged Structure\]. BenchChem, \[2026\]. \[Online PDF\]. Available at: \[https://www.benchchem.com/product/b3425073/docs#introduction-the-6-hydroxy-4h-chromen-4-one-scaffold-as-a-privileged-structure\]](#)

Disclaimer & Data Validity:

The information provided in this document is for Research Use Only (RUO) and is strictly not intended for diagnostic or therapeutic procedures. While BenchChem strives to provide accurate protocols, we make no warranties, express or implied, regarding the fitness of this product for every specific experimental setup.

Technical Support: The protocols provided are for reference purposes. Unsure if this reagent suits your experiment?

Need Industrial/Bulk Grade? [Request Custom Synthesis Quote](#)

BenchChem

Our mission is to be the trusted global source of essential and advanced chemicals, empowering scientists and researchers to drive progress in science and industry.

Contact

Address: 3281 E Guasti Rd
Ontario, CA 91761, United States
Phone: (601) 213-4426
Email: info@benchchem.com

[Contact our Ph.D. Support Team for a compatibility check](#)