

# Troubleshooting Tebufloquin bioassay variability

**Author:** BenchChem Technical Support Team. **Date:** December 2025

## Compound of Interest

Compound Name: *Tebufloquin*

Cat. No.: *B3424904*

[Get Quote](#)

## Tebufloquin Bioassay Troubleshooting Center

Welcome to the technical support center for **tebufloquin** bioassays. This resource is designed for researchers, scientists, and drug development professionals to help troubleshoot variability and ensure the accuracy and reproducibility of your experimental results.

### Frequently Asked Questions (FAQs)

Q1: What is **tebufloquin** and what is its primary mechanism of action?

A1: **Tebufloquin** is a quinoline-based fungicide and acaricide.<sup>[1][2][3]</sup> Its primary mode of action is the inhibition of the mitochondrial electron transport chain (ETC) at Complex I (NADH:ubiquinone oxidoreductase).<sup>[3][4]</sup> By blocking this complex, **tebufloquin** disrupts the production of ATP, the main energy currency of the cell, leading to cellular death.<sup>[3]</sup>

Q2: Why am I seeing high variability in my IC50/EC50 values for **tebufloquin** between experiments?

A2: High variability in IC50 values is a common issue in bioassays and can stem from multiple sources.<sup>[5][6][7]</sup> For mitochondrial inhibitors like **tebufloquin**, factors such as the physiological state of the test organism, subtle differences in assay conditions, and the chemical properties of the compound itself can significantly influence the outcome. It is common to see 2- to 5-fold variations in IC50 values even when using the same cell line or organism.<sup>[6]</sup>

Q3: Can the choice of bioassay method affect the results for **tebufloquin**?

A3: Absolutely. The methodology used to assess the efficacy of **tebufloquin** can lead to different IC50 values.[5][7] For example, a whole-organism assay (e.g., fungal growth inhibition on agar) may yield different results compared to an in vitro assay using isolated mitochondria due to factors like compound uptake, metabolism, and distribution in the whole organism.

Q4: How does the health and life stage of the target organism impact bioassay results?

A4: The health, age, and developmental stage of the test organisms are critical factors that can introduce variability.[8] For instance, different life stages of fungi or mites may exhibit varying sensitivity to **tebufloquin**. Ensuring a consistent and healthy population of test subjects is crucial for reproducible results.

Q5: Could resistance development be a reason for observing higher than expected IC50 values?

A5: Yes, if the organism you are testing has been previously exposed to **tebufloquin** or other Complex I inhibitors, it may have developed resistance.[9][10] Resistance can arise from target-site mutations or metabolic degradation of the compound.[11] It is advisable to use a well-characterized, susceptible strain as a control in your experiments.

## Troubleshooting Guide

### Problem 1: High Variability in IC50 Values Between Replicates

- Possible Cause: Inconsistent experimental setup.
  - Solution: Ensure all reagents are properly stored and equilibrated to the assay temperature before use.[12] Use calibrated pipettes and ensure thorough mixing of all solutions. Run a standard compound with a known IC50 to validate the assay setup.
- Possible Cause: Fluctuation in initial cell/organism density.
  - Solution: Standardize the initial number of cells, spores, or organisms in each well or plate.[5] High cell densities can lead to an artificially high IC50 value.
- Possible Cause: Inaccurate drug dilutions.

- Solution: Prepare fresh serial dilutions of **tebufloquin** for each experiment from a well-characterized stock solution.[5] Given that **tebufloquin** is insoluble in water, ensure it is fully dissolved in a suitable solvent like ethanol or acetone before preparing aqueous dilutions.[4]

## Problem 2: Poor Dose-Response Curve

- Possible Cause: Inappropriate concentration range.
  - Solution: The concentration range of **tebufloquin** tested may be too high or too low to generate a complete sigmoidal curve. Conduct a preliminary range-finding experiment to determine the optimal concentration range for your specific assay.
- Possible Cause: Compound precipitation.
  - Solution: **Tebufloquin** has low water solubility.[4] Visually inspect your assay plates for any signs of precipitation, especially at higher concentrations. If precipitation occurs, you may need to adjust the solvent concentration or use a different formulation.

## Problem 3: IC50 Values Differ Significantly from Published Data

- Possible Cause: Differences in assay protocols.
  - Solution: Carefully compare your protocol with the published literature.[13] Pay close attention to details such as incubation time, temperature, media composition, and the method used for data analysis.[5][7]
- Possible Cause: Different strains or isolates of the test organism.
  - Solution: The susceptibility to fungicides can vary significantly between different strains of the same species. Ensure you are using the same strain as cited in the literature, or characterize the susceptibility of your strain.

## Data Presentation

The variability in reported efficacy values for mitochondrial inhibitors is a known challenge. The following table is a conceptual representation of how to structure your experimental data to track and identify sources of variability.

Parameter	Experiment 1	Experiment 2	Experiment 3	Literature Value
Organism/Cell Line	Aspergillus nidulans	Aspergillus nidulans	Botrytis cinerea	Aspergillus nidulans
Assay Type	Mitochondrial Respiration	Fungal Growth Inhibition	Fungal Growth Inhibition	Mitochondrial Respiration
Media/Buffer	YPD Broth	Potato Dextrose Agar	Potato Dextrose Agar	Minimal Media
Incubation Time (hr)	2	72	72	2
Temperature (°C)	30	25	25	30
IC50 (µM)	0.5	1.2	2.5	0.4
Standard Deviation	0.05	0.2	0.4	N/A

## Experimental Protocols

### Protocol: Mitochondrial Complex I Activity Assay

This protocol is adapted for measuring the effect of **tebufloquin** on mitochondrial Complex I activity in isolated mitochondria.

#### 1. Isolation of Mitochondria:

- Isolate mitochondria from your target organism (e.g., fungal mycelia, cultured cells) using a suitable protocol, such as differential centrifugation with a mitochondria isolation kit.[\[14\]](#)
- Determine the protein concentration of the mitochondrial suspension.

#### 2. Assay Procedure:

- Prepare a reaction buffer (e.g., 25 mM potassium phosphate, 5 mM MgCl<sub>2</sub>, pH 7.2).

- In a 96-well plate, add the reaction buffer, isolated mitochondria (e.g., 5-10  $\mu\text{g}$  of protein), and various concentrations of **tebufloquin** (dissolved in a suitable solvent). Include a solvent-only control.
- To measure specific Complex I activity, prepare a parallel set of wells containing a known Complex I inhibitor, such as rotenone, for background subtraction.[15]
- Initiate the reaction by adding NADH (final concentration  $\sim 0.2$  mM) and a suitable electron acceptor like decylubiquinone.[15]
- Immediately measure the decrease in absorbance at 340 nm (due to NADH oxidation) over several minutes using a microplate reader in kinetic mode.[16]

### 3. Data Analysis:

- Calculate the rate of NADH oxidation ( $\Delta A_{340}/\text{min}$ ) for each concentration of **tebufloquin**.
- Subtract the rate observed in the presence of rotenone to get the specific Complex I activity.
- Plot the specific Complex I activity against the **tebufloquin** concentration and fit the data to a dose-response curve to determine the IC<sub>50</sub> value.

## Visualizations

### Tebufloquin's Mechanism of Action

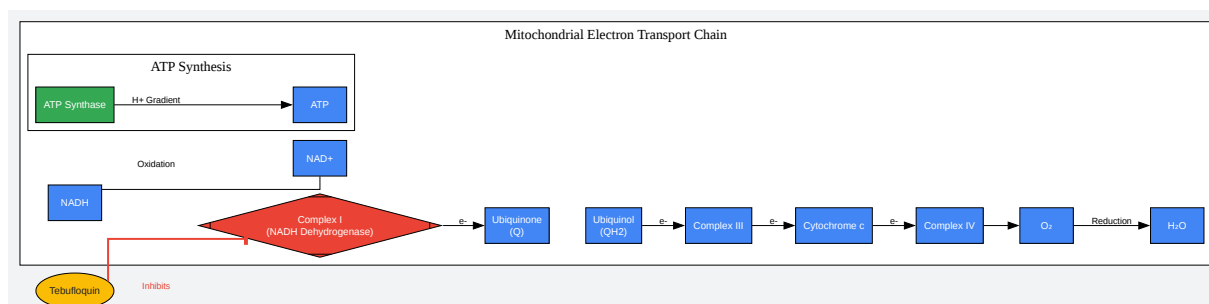

[Click to download full resolution via product page](#)

Caption: **Tebufloquin** inhibits Complex I of the mitochondrial electron transport chain.

## General Bioassay Workflow

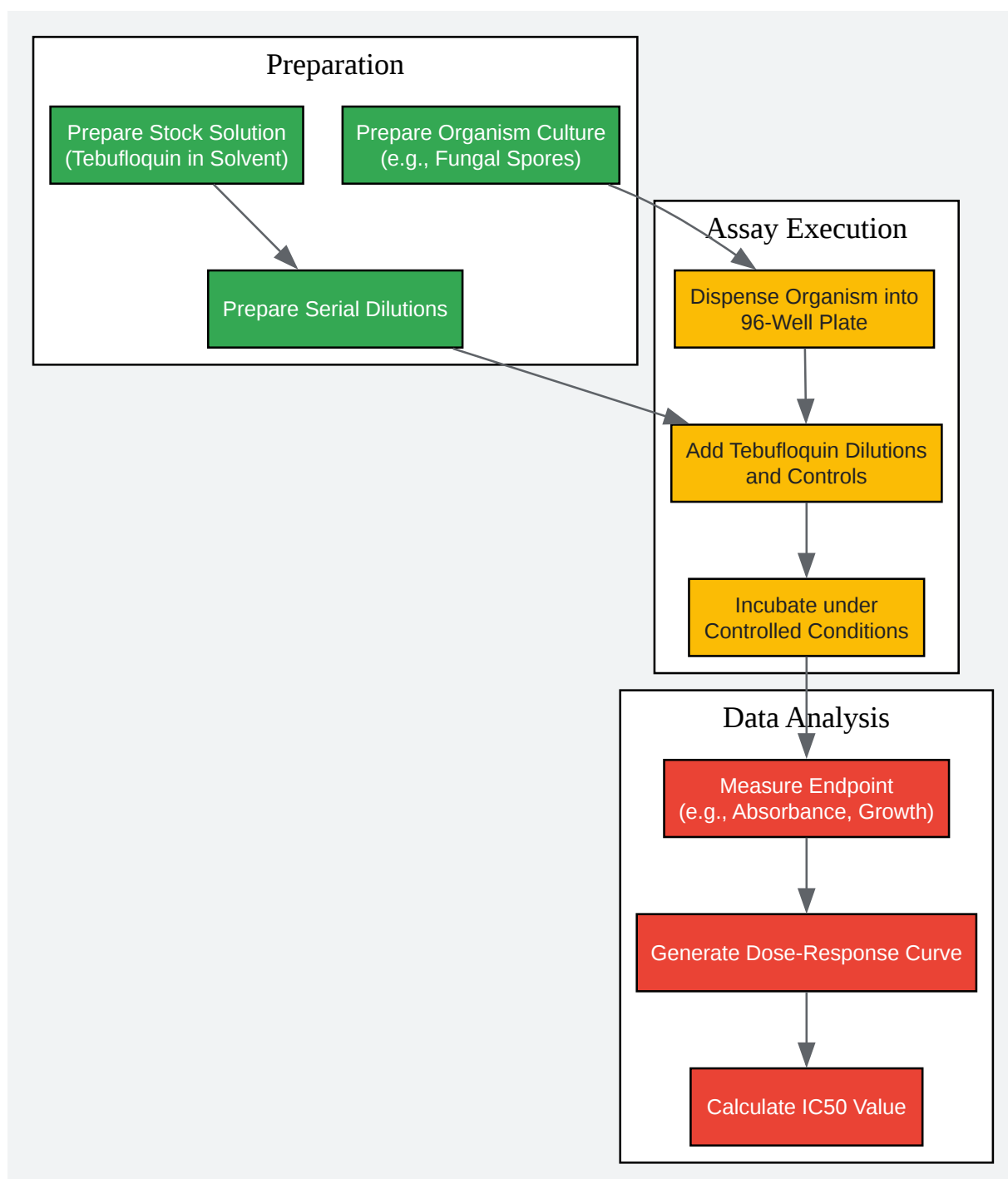

[Click to download full resolution via product page](#)

Caption: A generalized workflow for determining the IC50 of **tebufloquin**.

## Troubleshooting Logic

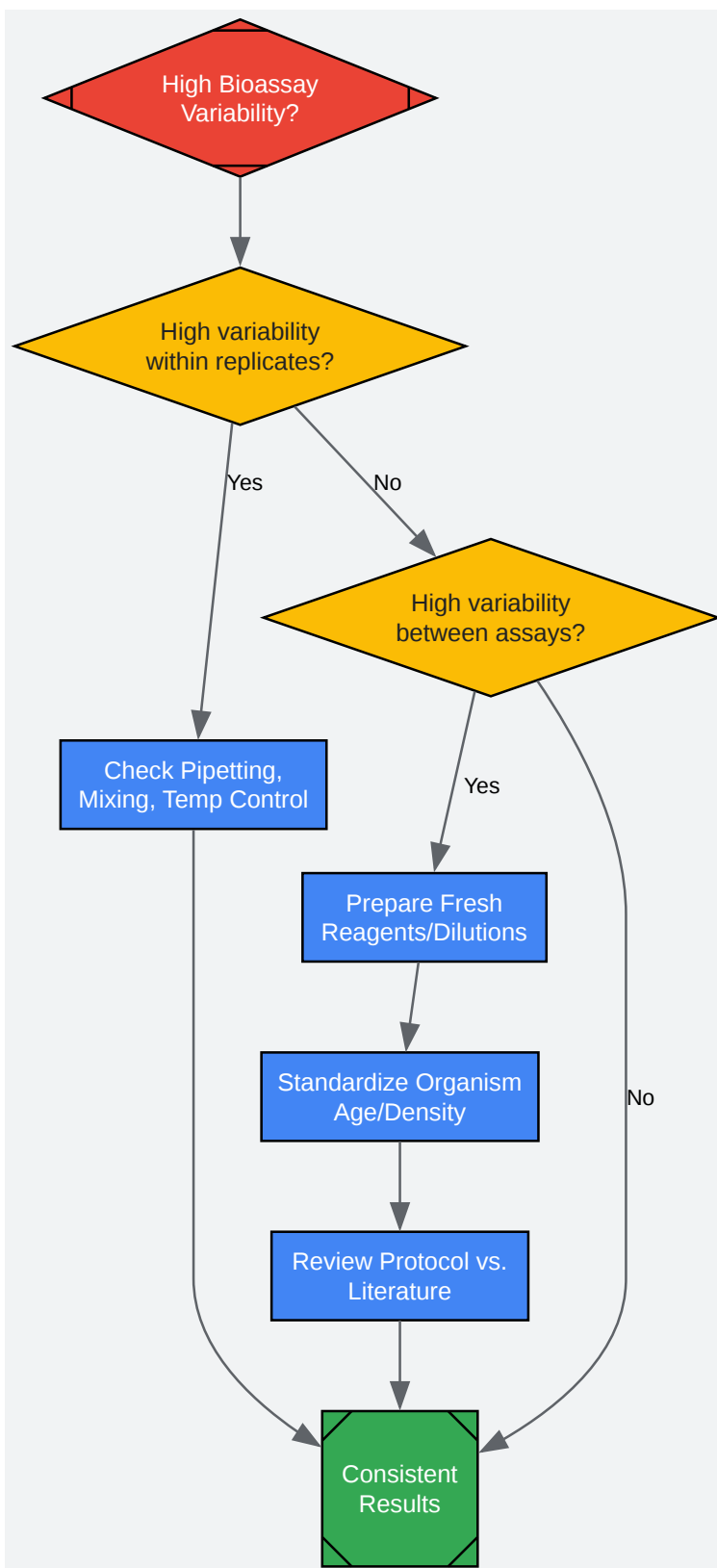

[Click to download full resolution via product page](#)

Caption: A decision tree for troubleshooting common sources of bioassay variability.



### Need Custom Synthesis?

BenchChem offers custom synthesis for rare earth carbides and specific isotopic labeling.

Email: [info@benchchem.com](mailto:info@benchchem.com) or [Request Quote Online](#).

## References

- 1. Tebufloquin | C17H20FNO2 | CID 11629002 - PubChem [pubchem.ncbi.nlm.nih.gov]
- 2. Page loading... [guidechem.com]
- 3. Tebufloquin [item.herts.ac.uk]
- 4. 376645-78-2 · Tebufloquin Standard · 206-20621[Detail Information][Laboratory Chemicals-FUJIFILM Wako Pure Chemical Corporation [labchem-wako.fujifilm.com]
- 5. benchchem.com [benchchem.com]
- 6. researchgate.net [researchgate.net]
- 7. Use of Different Parameters and Equations for Calculation of IC50 Values in Efflux Assays: Potential Sources of Variability in IC50 Determination - PMC [pmc.ncbi.nlm.nih.gov]
- 8. journals.rdagriculture.in [journals.rdagriculture.in]
- 9. researchgate.net [researchgate.net]
- 10. Acaricides Resistance in Ticks: Selection, Diagnosis, Mechanisms, and Mitigation - PMC [pmc.ncbi.nlm.nih.gov]
- 11. Mechanisms of evolved herbicide resistance - PMC [pmc.ncbi.nlm.nih.gov]
- 12. bioassaysys.com [bioassaysys.com]
- 13. Combining IC50 or Ki Values from Different Sources Is a Source of Significant Noise - PMC [pmc.ncbi.nlm.nih.gov]
- 14. protocols.io [protocols.io]
- 15. sigmaaldrich.com [sigmaaldrich.com]
- 16. Cell Mitochondrial Complex I (NADH-CoQ Reductase) Activity Assay Kit - Elabscience® [elabscience.com]
- To cite this document: BenchChem. [Troubleshooting Tebufloquin bioassay variability]. BenchChem, [2025]. [Online PDF]. Available at: [https://www.benchchem.com/product/b3424904#troubleshooting-tebufloquin-bioassay-variability]

**Disclaimer & Data Validity:**

The information provided in this document is for Research Use Only (RUO) and is strictly not intended for diagnostic or therapeutic procedures. While BenchChem strives to provide accurate protocols, we make no warranties, express or implied, regarding the fitness of this product for every specific experimental setup.

**Technical Support:** The protocols provided are for reference purposes. Unsure if this reagent suits your experiment? [[Contact our Ph.D. Support Team for a compatibility check](#)]

**Need Industrial/Bulk Grade?** [Request Custom Synthesis Quote](#)

## BenchChem

Our mission is to be the trusted global source of essential and advanced chemicals, empowering scientists and researchers to drive progress in science and industry.

### Contact

Address: 3281 E Guasti Rd  
Ontario, CA 91761, United States  
Phone: (601) 213-4426  
Email: [info@benchchem.com](mailto:info@benchchem.com)