

Technical Support Center: Industrial Production of Ethylstyrene

Author: BenchChem Technical Support Team. **Date:** April 2026

Compound of Interest

Compound Name: 2-Ethylstyrene

CAS No.: 28106-30-1

Cat. No.: B3423024

[Get Quote](#)

This technical support center provides troubleshooting guidance and frequently asked questions for researchers, scientists, and drug development professionals engaged in the industrial production of ethylstyrene, primarily through the dehydrogenation of ethylbenzene.

Troubleshooting Guides

This section addresses common issues encountered during the synthesis of ethylstyrene. Each problem is presented with potential causes and recommended solutions in a question-and-answer format.

Issue 1: Low Ethylbenzene Conversion Rate

- **Question:** Our ethylbenzene conversion rate is significantly lower than the expected equilibrium conversion of around 80%. What are the potential causes and how can we troubleshoot this?
- **Answer:** A low conversion rate can be attributed to several factors, primarily related to catalyst activity and reaction conditions.

Potential Causes:

- Catalyst Deactivation: The potassium-promoted iron oxide catalyst is susceptible to deactivation.[1][2][3]
 - Coke Formation: Carbonaceous deposits (coke) can block active sites on the catalyst surface.[1][4] This is often a rapid initial deactivation process.[1]
 - Potassium Promoter Loss: Migration, redistribution, or volatilization of the potassium promoter can severely reduce catalyst activity over the long term.[1][2][3] In fact, potassium loss has been identified as a dominant degradation mechanism.[1]
 - Changes in Iron Oxidation State: Reduction of the active Fe^{3+} sites to less active Fe^{2+} can decrease catalytic performance.[2]
 - Physical Degradation: The catalyst structure can physically degrade over time.[1][3]
- Suboptimal Reaction Temperature: The dehydrogenation of ethylbenzene is highly endothermic, requiring temperatures around 620°C . [5][6] Insufficient temperature will lead to lower conversion.
- Inadequate Steam to Ethylbenzene Ratio: Steam plays a crucial role in the process.[5][6] It supplies heat for the endothermic reaction, lowers the partial pressure of ethylbenzene to shift the equilibrium towards styrene, and helps clean the catalyst by reacting with coke. [5] An incorrect ratio can hinder these functions.
- Reactor Feed Impurities: Contaminants in the ethylbenzene feed can poison the catalyst.

Troubleshooting Steps:

- Verify Operating Temperatures: Ensure that the reactor inlet and bed temperatures are within the optimal range (typically around 620°C). [5] To compensate for catalyst deactivation over time, a gradual increase in reactor inlet temperatures is a common practice.[1]
- Analyze Catalyst Activity:

- Take a sample of the catalyst and perform characterization analyses (e.g., X-ray fluorescence (XRF), X-ray diffraction (XRD), scanning electron microscopy (SEM)) to check for coke deposition, potassium levels, and changes in the iron oxide phase.[2]
- Compare the performance of the current catalyst to a fresh catalyst under identical conditions.
- Check Steam to Ethylbenzene Ratio: Verify that the molar ratio of steam to ethylbenzene in the feed meets the process specifications.
- Analyze Feed Purity: Test the ethylbenzene feed for any potential catalyst poisons.
- Catalyst Regeneration/Replacement: If catalyst deactivation is confirmed to be the primary issue, consider regeneration or replacement. While coke deposition can be reversible, potassium loss is a key factor in irreversible deactivation.[2] A typical catalyst life is about two years.[5]

Issue 2: Poor Styrene Selectivity and High By-product Formation

- Question: We are observing a decrease in styrene selectivity and an increase in by-products like benzene and toluene. What could be causing this and what are the solutions?
- Answer: Poor selectivity indicates that side reactions are becoming more prominent.

Potential Causes:

- High Reaction Temperatures: While high temperatures favor the endothermic dehydrogenation of ethylbenzene, excessively high temperatures can promote thermal cracking, leading to the formation of benzene, toluene, and other by-products.[5][7]
- Catalyst Deactivation: A deactivated catalyst can lose its selectivity for the desired reaction.[4] For instance, changes in the catalyst's active sites can enhance coking activity.[2]
- Incorrect Residence Time: If the reactants spend too much time in the reactor, the probability of side reactions increases.

- Low Steam to Ethylbenzene Ratio: Insufficient steam can lead to higher partial pressures of hydrocarbons, favoring side reactions.[5]

Troubleshooting Steps:

- Optimize Reaction Temperature: Carefully control the reactor temperature to balance conversion and selectivity. Avoid temperature excursions above the recommended operating window.
- Evaluate Catalyst Performance: As with low conversion, assess the health of your catalyst. A fresh or regenerated catalyst will generally offer better selectivity.
- Adjust Feed Flow Rate: Ensure the space velocity is appropriate for the desired conversion and selectivity.
- Verify Steam to Ethylbenzene Ratio: Maintain the correct steam to ethylbenzene ratio to suppress side reactions.[5]

Issue 3: Difficulties in Styrene Purification

- Question: We are struggling to achieve high-purity styrene due to the presence of unreacted ethylbenzene. What are the challenges and recommended purification methods?
- Answer: The separation of styrene from ethylbenzene is a significant challenge due to their very close boiling points (145.2°C for styrene and 136.2°C for ethylbenzene).[8]

Challenges:

- Close Boiling Points: Conventional distillation is difficult and energy-intensive.[8]
- Styrene Polymerization: Styrene can polymerize at the high temperatures required for distillation, leading to product loss and equipment fouling.[9]

Recommended Purification Methods:

- Vacuum Distillation: Operating the distillation columns under vacuum lowers the boiling points of the components, reducing the risk of styrene polymerization.[5][9]

- Extractive Distillation: This is a common industrial technique where a solvent is added to the mixture to alter the relative volatilities of styrene and ethylbenzene, making separation easier.[8]
- Use of Polymerization Inhibitors: During distillation, inhibitors such as dinitrophenols or phenylenediamines are added to prevent the polymerization of styrene.[8]
- Alternative Separation Technologies: For very high purity requirements, advanced techniques like stripping crystallization are being explored.[10][11]

Frequently Asked Questions (FAQs)

1. What is the typical catalyst used for ethylbenzene dehydrogenation?

The most common catalyst is potassium-promoted iron oxide, often with other promoters like chromium oxide.[1][5] The active sites are believed to be KFeO_2 . [1]

2. Why is steam used in the process?

Steam serves three main purposes[5][6] :

- It provides the necessary heat for the endothermic reaction.
- It lowers the partial pressure of ethylbenzene, which shifts the reaction equilibrium to favor the formation of styrene.
- It helps to remove coke deposits from the catalyst surface through the water-gas shift reaction.

3. What are the main by-products of ethylstyrene production?

The primary by-products from the dehydrogenation of ethylbenzene are benzene and toluene. [7][12] These are formed through side reactions like thermal cracking.[5]

4. What are the typical operating conditions for the dehydrogenation reactor?

Industrial reactors typically operate at temperatures around 620°C and at the lowest practicable pressure to favor the forward reaction.[5]

5. How is the catalyst regenerated?

While coke deposition is a reversible deactivation mechanism that can be addressed by gasification with steam, the loss of the potassium promoter is largely irreversible and is a key factor limiting the catalyst's lifetime.[1][2] Therefore, the catalyst is typically replaced after its operational life, which is approximately two years.[5]

6. What are the safety concerns associated with ethylstyrene (styrene) production?

Styrene is a flammable liquid and its vapors can form explosive mixtures with air. Acute exposure can cause irritation to the mucous membranes and eyes, as well as gastrointestinal effects.[13] Chronic exposure can affect the central nervous system.[13] It is also important to prevent unwanted polymerization, which can be exothermic and lead to a runaway reaction. Proper handling procedures, ventilation, and the use of personal protective equipment are essential.[14]

Quantitative Data

Table 1: Typical Operating Conditions and Performance

Parameter	Value	Reference
Reactor Temperature	~ 620 °C	[5]
Pressure	As low as practicable	[5]
Steam to Ethylbenzene Molar Ratio	~ 11	[15]
Ethylbenzene Conversion (at equilibrium)	~ 80%	[5]
Styrene Yield	88% - 93%	[12]
Catalyst Lifespan	~ 2 years	[5]

Table 2: Catalyst Deactivation Factors

Deactivation Mechanism	Impact on Catalyst Activity	Reference
Coke Formation (1st month)	Activity reduced to 50% of fresh catalyst	[1]
Coke Formation (30th month)	Activity reduced to 40% of fresh catalyst	[1]
Potassium Loss (end of 30-month operation)	Activity reduced to less than 10% of initial value	[1]

Experimental Protocols

Protocol 1: Catalytic Dehydrogenation of Ethylbenzene (Laboratory Scale)

This protocol outlines a general procedure for the dehydrogenation of ethylbenzene in a laboratory setting.

Materials and Equipment:

- Fixed-bed tubular reactor
- Furnace with temperature controller
- Mass flow controllers for gases and liquids
- Syringe pump for liquid feed
- Potassium-promoted iron oxide catalyst
- Ethylbenzene (high purity)
- Deionized water
- Nitrogen or other inert gas for purging
- Condenser and collection vessel
- Gas chromatograph (GC) for product analysis

Procedure:

- **Catalyst Loading:** Pack a known amount of the catalyst into the tubular reactor, securing it with quartz wool plugs.
- **System Purge:** Purge the reactor system with an inert gas (e.g., nitrogen) for at least 30 minutes to remove any air.
- **Heating:** Heat the reactor to the desired reaction temperature (e.g., 620°C) under a continuous flow of inert gas.
- **Feed Introduction:**
 - Once the temperature is stable, stop the inert gas flow.
 - Introduce the water feed using a syringe pump and vaporize it before it enters the reactor to generate steam.
 - Introduce the ethylbenzene feed using a separate syringe pump and vaporize it.
 - Mix the vaporized ethylbenzene and steam before they enter the reactor. The molar ratio should be carefully controlled (e.g., 11:1 steam to ethylbenzene).[\[15\]](#)
- **Reaction:** Allow the reaction to proceed for a set period.
- **Product Collection:** The reactor effluent is passed through a condenser to liquefy the organic and aqueous phases. The non-condensable gases (mainly hydrogen) can be vented or collected for analysis.
- **Product Analysis:** Analyze the collected liquid sample using a gas chromatograph (GC) to determine the conversion of ethylbenzene and the selectivity to styrene and by-products.
- **Shutdown:** After the experiment, stop the ethylbenzene and water feeds and cool the reactor down to room temperature under a flow of inert gas.

Visualizations

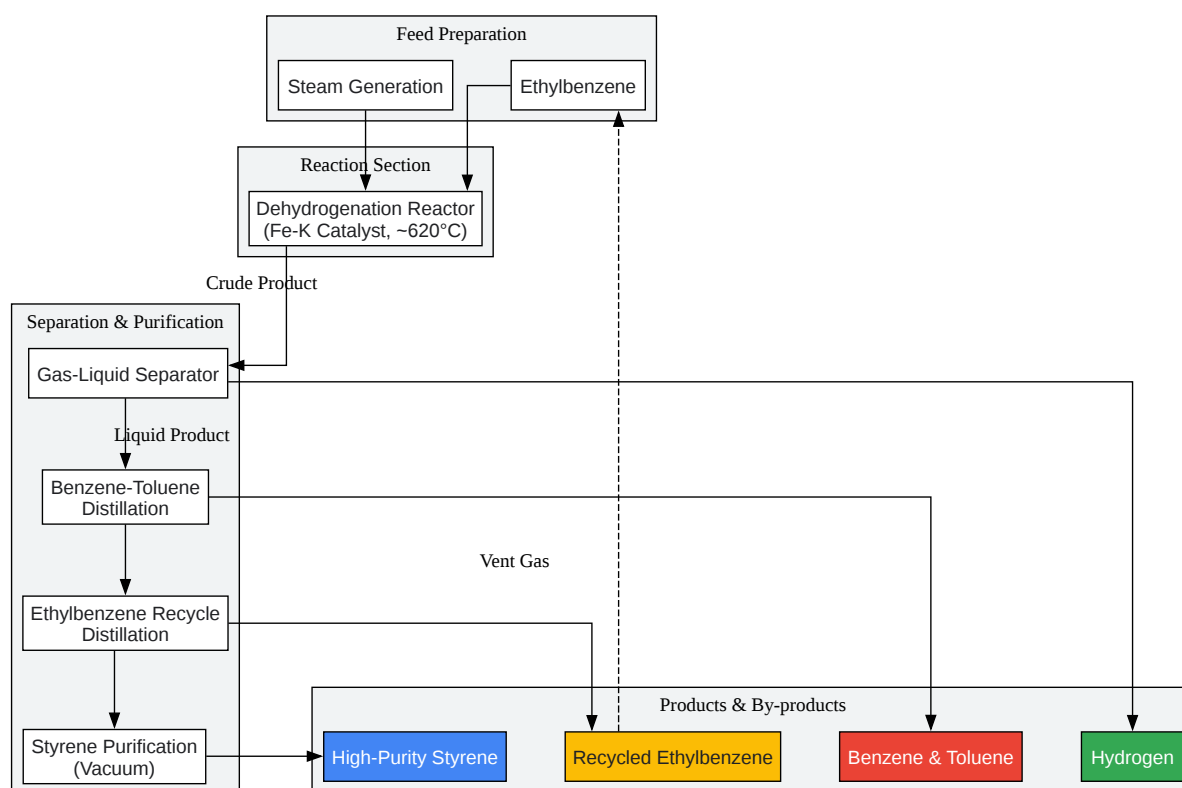

[Click to download full resolution via product page](#)

Caption: Workflow for the industrial production of ethylstyrene.

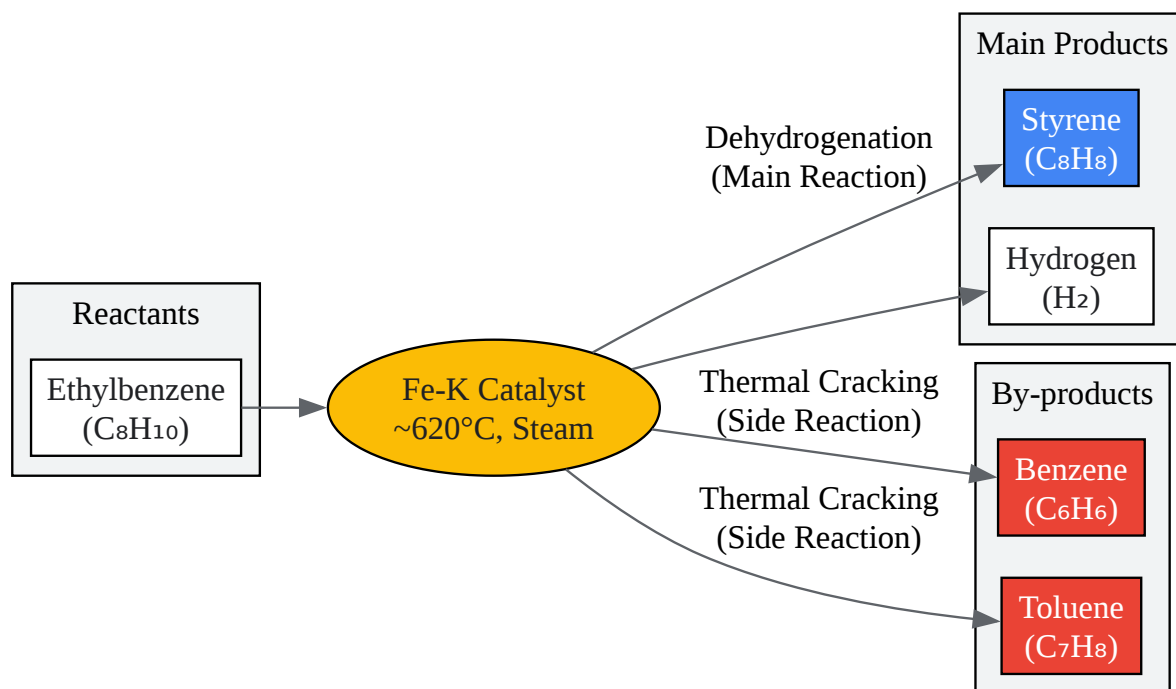

[Click to download full resolution via product page](#)

Caption: Chemical reaction pathways in ethylstyrene synthesis.

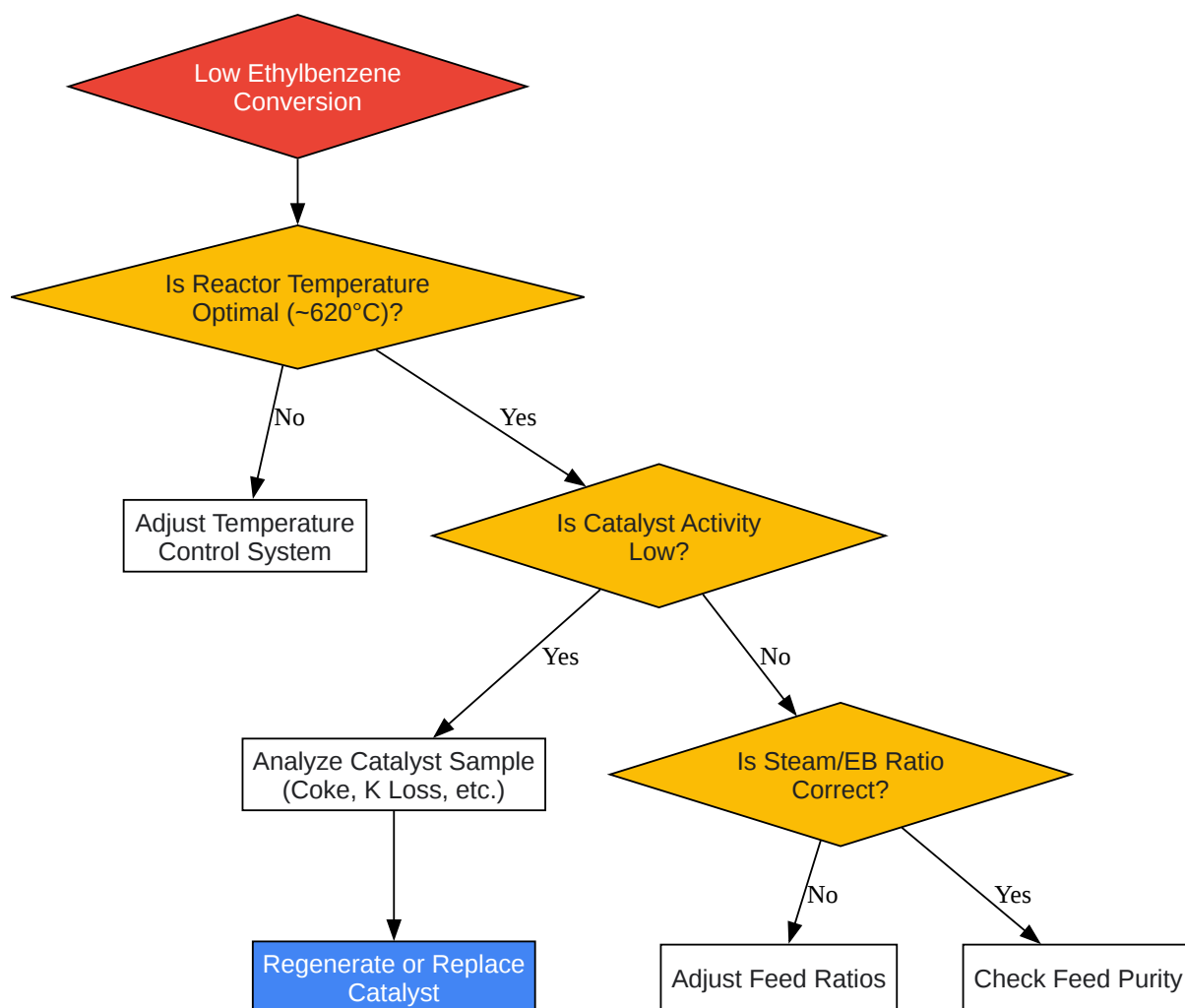

[Click to download full resolution via product page](#)

Caption: Troubleshooting decision tree for low conversion.

Need Custom Synthesis?

BenchChem offers custom synthesis for rare earth carbides and specific isotopic labeling.

Email: info@benchchem.com or [Request Quote Online](#).

References

- 1. (28e) Modeling Catalyst Deactivation In Dehydrogenation of Ethylbenzene to Styrene | AIChE [proceedings.aiche.org]
- 2. researchgate.net [researchgate.net]
- 3. researchgate.net [researchgate.net]
- 4. researchgate.net [researchgate.net]
- 5. michiganfoam.com [michiganfoam.com]
- 6. ecoquery.ecoinvent.org [ecoquery.ecoinvent.org]
- 7. researchgate.net [researchgate.net]
- 8. Styrene Purification by Guest-Induced Restructuring of Pillar[6]arene - PMC [pubmed.ncbi.nlm.nih.gov]
- 9. Simulation of the styrene production process via catalytic dehydrogenation of ethylbenzene using CHEMCAD® process simulator [redalyc.org]
- 10. pure.lib.cgu.edu.tw [pure.lib.cgu.edu.tw]
- 11. researchgate.net [researchgate.net]
- 12. Styrene Production Process: Key Routes and Industrial Efficiency [chemanalyst.com]
- 13. [19january2017snapshot.epa.gov](https://www.epa.gov/19january2017snapshot) [[19january2017snapshot.epa.gov](https://www.epa.gov/19january2017snapshot)]
- 14. niehs.nih.gov [niehs.nih.gov]
- 15. files.core.ac.uk [files.core.ac.uk]
- To cite this document: BenchChem. [Technical Support Center: Industrial Production of Ethylstyrene]. BenchChem, [2026]. [Online PDF]. Available at: [<https://www.benchchem.com/product/b3423024/docs#technical-support-center-industrial-production-of-ethylstyrene>]

Disclaimer & Data Validity:

The information provided in this document is for Research Use Only (RUO) and is strictly not intended for diagnostic or therapeutic procedures. While BenchChem strives to provide accurate protocols, we make no warranties, express or implied, regarding the fitness of this product for every specific experimental setup.

Technical Support: The protocols provided are for reference purposes. Unsure if this reagent suits your experiment?

Need Industrial/Bulk Grade? [Request Custom Synthesis Quote](#)

BenchChem

Our mission is to be the trusted global source of essential and advanced chemicals, empowering scientists and researchers to drive progress in science and industry.

Contact

Address: 3281 E Guasti Rd
Ontario, CA 91761, United States
Phone: (601) 213-4426
Email: info@benchchem.com

[Contact our Ph.D. Support Team for a compatibility check](#)