

Spectroscopic Characterization of 1,3-Cyclohexadiene: A Technical Guide

Author: BenchChem Technical Support Team. **Date:** May 2026

Compound of Interest

Compound Name:	1,3-Cyclohexadiene
CAS No.:	29797-09-9
Cat. No.:	B3423345

[Get Quote](#)

Executive Summary

1,3-Cyclohexadiene (1,3-CHD) represents a canonical conjugated diene system embedded within a cyclic framework. Unlike its acyclic counterparts, 1,3-CHD is locked in a cis-diene conformation, making it a critical substrate for cycloaddition reactions (e.g., Diels-Alder) and a model system for studying electrocyclic ring-opening mechanisms (e.g., Vitamin D synthesis).

This guide provides a rigorous, self-validating framework for the spectroscopic identification and quality control of 1,3-CHD. By synthesizing experimental data with theoretical causality, we establish a multi-modal characterization protocol ensuring sample integrity and high-fidelity data acquisition.

Critical Handling & Sample Preparation (The "Zero Step")

Before any spectroscopic analysis, the integrity of 1,3-CHD must be assured. This molecule is highly susceptible to auto-oxidation and dimerization.

Causality & Protocol

- Oxidation Risk: The conjugated system lowers the bond dissociation energy of the allylic C-H bonds (C5/C6), facilitating radical formation and subsequent peroxidation.
- Dimerization: Spontaneous Diels-Alder dimerization occurs at ambient temperatures.

Self-Validating Protocol:

- Storage: Store at -20°C under Argon. Commercial samples are typically stabilized with BHT (Butylated hydroxytoluene).
- Purification: If high-purity spectroscopy is required (e.g., for photophysical studies), distill under reduced pressure into a liquid nitrogen-cooled receiver immediately prior to use.
- Solvent Choice: Use degassed spectroscopic-grade solvents (e.g., Cyclohexane for UV, CDCl₃ for NMR) to prevent oxygen quenching or radical initiation.

UV-Visible Spectroscopy: The Hallmark of Conjugation

UV-Vis spectroscopy provides the primary confirmation of the conjugated

-system. The rigid s-cis conformation of the diene within the ring results in a bathochromic shift compared to acyclic analogs.

Woodward-Fieser Analysis vs. Experimental Data[1]

We validate the structure by comparing the theoretical absorbance maximum (

) with experimental observation.[1]

Parameter	Value	Contribution
Base Value	Homoannular Diene	253 nm
Substituents	2 x Ring Residues (at C1, C4)	2 x 5 = 10 nm
Calculated	263 nm	
Experimental	(in Ethanol)	~256 - 260 nm

Note: The slight discrepancy typically arises from solvent corrections and the specific ring strain affecting orbital overlap.

Photochemical Validity Check

Irradiation of 1,3-CHD results in electrocyclic ring opening. A "self-validating" check for photo-stability involves monitoring the disappearance of the 260 nm band and the appearance of structured bands associated with 1,3,5-hexatriene.

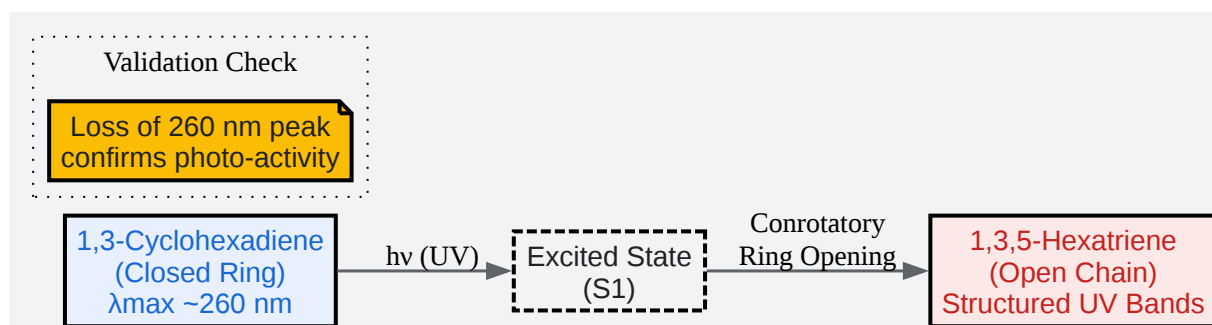

[Click to download full resolution via product page](#)

Caption: Photochemical pathway utilized for stability validation. 1,3-CHD undergoes electrocyclic ring opening to hexatriene upon UV exposure.

Vibrational Spectroscopy (IR)

Infrared spectroscopy distinguishes the conjugated diene from isolated alkene impurities (e.g., 1,4-cyclohexadiene or cyclohexene).

Key Diagnostic Bands

Mode	Frequency (cm ⁻¹)	Causality
=C-H Stretch	3030 - 3050	hybridized C-H bonds.
C=C Stretch	1570 - 1600	Conjugation lowers the force constant compared to isolated alkenes (typically ~1650 cm ⁻¹).
-CH ₂ - Stretch	2800 - 2950	hybridized C-H bonds at C5/C6.
=C-H Bend (oop)	~700 - 750	Out-of-plane bending, characteristic of cis-alkenes.

Expert Insight: The lowering of the C=C stretching frequency to near 1600 cm⁻¹ is a definitive marker of the conjugated system. If a strong band appears >1640 cm⁻¹, suspect contamination with non-conjugated isomers or oxidation products.

Nuclear Magnetic Resonance (NMR)[3][4][5][6]

NMR provides the most detailed structural proof. Due to the

symmetry of 1,3-CHD, the spectrum is simpler than the atom count suggests but shows complex higher-order coupling.

¹H NMR (Proton)

The spectrum is characterized by a "roofing" effect due to the AA'BB' spin system of the olefinic protons.

- Solvent: CDCl₃ (referenced to 7.26 ppm).
- Symmetry:
 - H1, H4 (Terminal Olefinic): Equivalent.
 - H2, H3 (Internal Olefinic): Equivalent.

- o H5, H6 (Methylene): Equivalent.

Proton Environment	Chemical Shift (, ppm)	Multiplicity	Interpretation
H2, H3	5.80 - 5.90	Multiplet	Internal protons of the diene system.
H1, H4	5.70 - 5.80	Multiplet	Terminal protons. Often overlap with H2/H3 to form a complex narrow multiplet.
H5, H6	2.10 - 2.20	Multiplet	Allylic methylene protons.

Expert Insight: Do not expect clean doublets or triplets for the olefinic region. The H1-H2 coupling (

) and long-range couplings create a complex second-order pattern.

¹³C NMR (Carbon)

Due to symmetry, only three distinct signals are observed.[2]

Carbon Environment	Chemical Shift (, ppm)	Assignment
C2, C3	~126 - 128	Internal olefinic carbons.
C1, C4	~124 - 126	Terminal olefinic carbons.
C5, C6	~22.0	Allylic methylene carbons.

Note: Exact shifts vary slightly with concentration and solvent. The key validation is the presence of exactly two signals in the alkene region and one in the aliphatic region.

Mass Spectrometry (MS)[8]

Mass spectrometry confirms the molecular weight and reveals characteristic fragmentation pathways driven by aromatization.

- Ionization Method: Electron Impact (EI, 70 eV).
- Molecular Ion (): m/z 80.

Fragmentation Pattern[8][9][10]

- Base Peak (m/z 79):
 - . The loss of a hydrogen atom is extremely favorable as it leads to the formation of the cyclohexadienyl cation, which has significant resonance stability and is a precursor to the benzene cation.
- Phenyl Cation (m/z 77):
 - . Further dehydrogenation leads to the phenyl cation.
- Retro-Diels-Alder (m/z 54): While less intense, the loss of acetylene (, 26 Da) or ethylene (, 28 Da) pathways are mechanistically relevant. Loss of ethylene from the parent ion via Retro-Diels-Alder yields the butadiene radical cation (m/z 54).

Integrated Characterization Workflow

The following diagram outlines the logical flow for validating a 1,3-CHD sample, prioritizing non-destructive methods first.

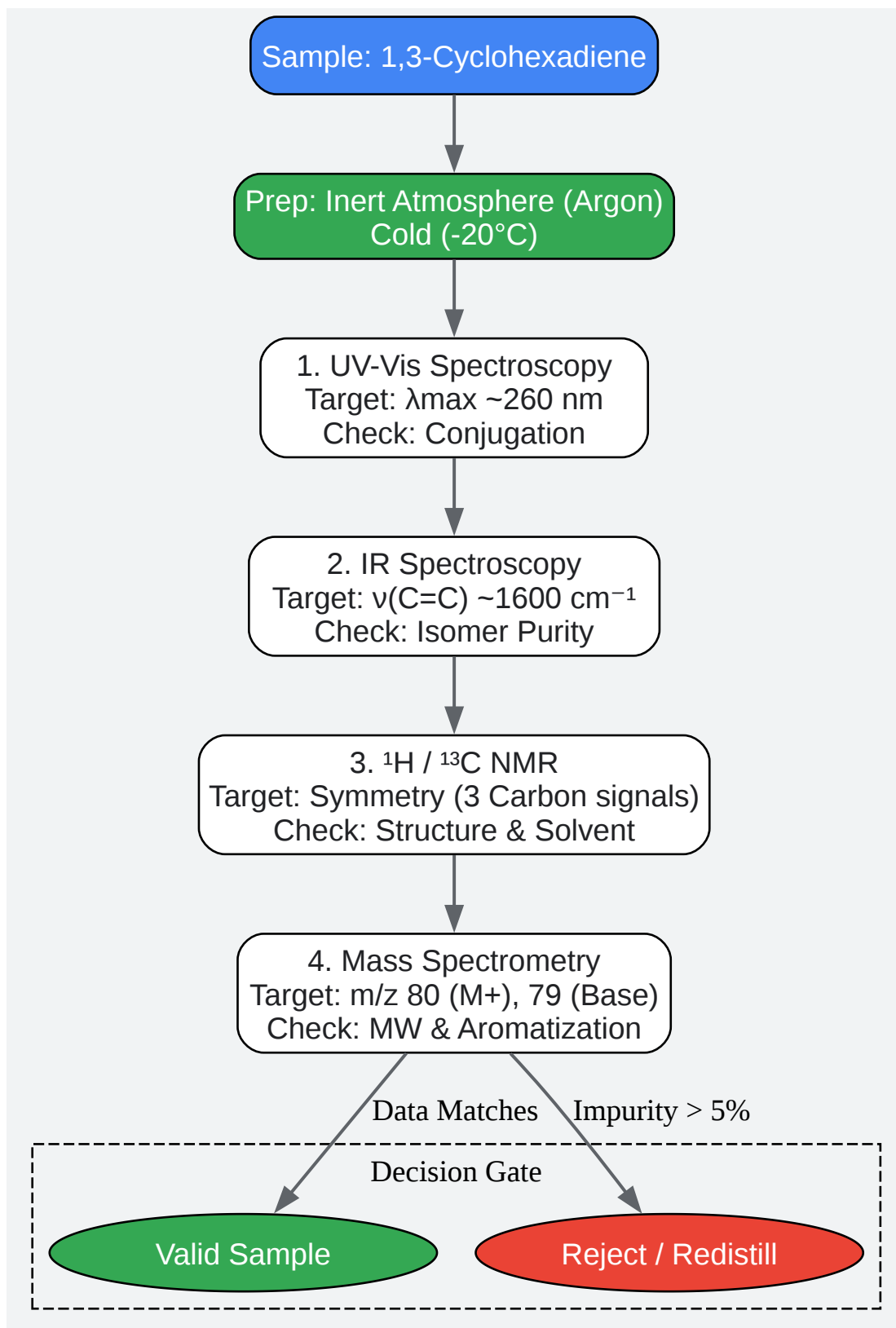

[Click to download full resolution via product page](#)

Caption: Step-by-step spectroscopic validation workflow ensuring sample integrity from preparation to final structural confirmation.

References

- NIST Mass Spectrometry Data Center. **1,3-Cyclohexadiene** Mass Spectrum. National Institute of Standards and Technology. [[Link](#)]
- NIST Infrared Spectroscopy Data. **1,3-Cyclohexadiene** IR Spectrum. National Institute of Standards and Technology. [[Link](#)]
- Woodward, R. B. Structure and the Absorption Spectra of -Unsaturated Ketones. J. Am. Chem. Soc. 1941, 63, 1123. (Foundational text for Woodward-Fieser Rules).^[3]
- SDBS. Spectral Database for Organic Compounds. **1,3-Cyclohexadiene** 1H and 13C NMR Data. [[Link](#)] (Search Index: **1,3-Cyclohexadiene**).
- Reich, H. J. Structure Determination Using NMR. University of Wisconsin-Madison. (Reference for AA'BB' splitting patterns in cyclic dienes). [[Link](#)]

Need Custom Synthesis?

BenchChem offers custom synthesis for rare earth carbides and specific isotopic labeling.

Email: info@benchchem.com or [Request Quote Online](#).

Sources

- 1. kdsfun.weebly.com [kdsfun.weebly.com]
- 2. brainly.com [brainly.com]
- 3. pharmaxchange.info [pharmaxchange.info]
- To cite this document: BenchChem. [Spectroscopic Characterization of 1,3-Cyclohexadiene: A Technical Guide]. BenchChem, [2026]. [Online PDF]. Available at: [<https://www.benchchem.com/product/b3423345/docs#spectroscopic-characterization-of-1-3-cyclohexadiene-a-technical-guide>]

Disclaimer & Data Validity:

The information provided in this document is for Research Use Only (RUO) and is strictly not intended for diagnostic or therapeutic procedures. While BenchChem strives to provide accurate protocols, we make no warranties, express or implied, regarding the fitness of this product for every specific experimental setup.

Technical Support: The protocols provided are for reference purposes. Unsure if this reagent suits your experiment?

Need Industrial/Bulk Grade? [Request Custom Synthesis Quote](#)

BenchChem

Our mission is to be the trusted global source of essential and advanced chemicals, empowering scientists and researchers to drive progress in science and industry.

Contact

Address: 3281 E Guasti Rd

Ontario, CA 91761, United States

Phone: (601) 213-4426

Email: info@benchchem.com

[Contact our Ph.D. Support Team for a compatibility check](#)