

# Reaction Kinetics of 2-Ethylstyrene Polymerization: Application Notes and Protocols

**Author:** BenchChem Technical Support Team. **Date:** April 2026

## Compound of Interest

Compound Name: 2-Ethylstyrene

CAS No.: 28106-30-1

Cat. No.: B3423024

[Get Quote](#)

For Researchers, Scientists, and Drug Development Professionals

This document provides a detailed overview of the reaction kinetics governing the polymerization of **2-ethylstyrene**. Due to a scarcity of specific kinetic data for **2-ethylstyrene** in publicly available literature, this guide focuses on the general principles and established protocols for the polymerization of substituted styrenes, using styrene as a primary reference point. The provided methodologies can be adapted by researchers to investigate and characterize the specific kinetic parameters of **2-ethylstyrene**.

## Introduction to 2-Ethylstyrene Polymerization

**2-Ethylstyrene** is a substituted styrene monomer with an ethyl group attached to the aromatic ring. This substitution influences the monomer's reactivity and the properties of the resulting polymer, poly(**2-ethylstyrene**). The polymerization of **2-ethylstyrene** can be achieved through various mechanisms, including free radical, anionic, and cationic polymerization. Each method offers distinct control over the polymerization process and the final polymer characteristics.

The ethyl group, being electron-donating, generally decreases the rate of free-radical polymerization compared to unsubstituted styrene.[1] Understanding the kinetics of these polymerization reactions is crucial for controlling the molecular weight, molecular weight distribution (polydispersity), and architecture of the polymer, which are critical parameters in applications such as drug delivery systems and advanced material development.

## Data Presentation: Kinetic Parameters for Styrene Polymerization

The following tables summarize key kinetic parameters for the polymerization of styrene, which can serve as a valuable reference for studies on **2-ethylstyrene**. It is important to note that these values will differ for **2-ethylstyrene** due to the electronic and steric effects of the ethyl substituent.

Table 1: Free Radical Polymerization of Styrene - Kinetic Parameters

Parameter	Symbol	Value	Units	Conditions
Propagation Rate Constant	$k_p$	$3.3 \times 10^2$	$L \text{ mol}^{-1} \text{ s}^{-1}$	60 °C
Termination Rate Constant	$k_t$	$7.2 \times 10^7$	$L \text{ mol}^{-1} \text{ s}^{-1}$	60 °C
Initiator Decomposition Rate Constant (AIBN)	$k_d$	$8.5 \times 10^{-6}$	$\text{s}^{-1}$	60 °C
Activation Energy for Propagation	$E_{a(p)}$	32.5	$\text{kJ mol}^{-1}$	Bulk
Activation Energy for Termination	$E_{a(t)}$	2.9 - 16.7	$\text{kJ mol}^{-1}$	Bulk

Note: AIBN refers to Azobisisobutyronitrile, a common free-radical initiator.

Table 2: Anionic Polymerization of Styrene in Tetrahydrofuran (THF) - Kinetic Parameters

Counter-ion	Propagation Rate Constant (k <sub>p</sub> )	Activation Energy (E <sub>a</sub> )
Li <sup>+</sup>	180	23.4
Na <sup>+</sup>	80	25.1
K <sup>+</sup>	60	25.5
Cs <sup>+</sup>	22	27.6

Values are given in L mol<sup>-1</sup> s<sup>-1</sup> for k<sub>p</sub> and kJ mol<sup>-1</sup> for E<sub>a</sub> at 25 °C.

Table 3: Cationic Polymerization of Styrene - Kinetic Parameters

Initiator System	Overall Rate Constant (k <sub>overall</sub> )	Overall Activation Energy (E <sub>a</sub> )
SnCl <sub>4</sub> /H <sub>2</sub> O	Varies with concentrations	Often negative, indicating faster rates at lower temperatures
BF <sub>3</sub> OEt <sub>2</sub> /H <sub>2</sub> O	Varies with concentrations	-

Cationic polymerization kinetics are highly sensitive to the specific initiator, co-initiator, solvent, and temperature, making it difficult to provide universal constants.

## Experimental Protocols

The following are detailed protocols for the primary methods of styrene polymerization, which can be adapted for **2-ethylstyrene**.

### Free Radical Polymerization (Bulk)

This protocol describes a conventional bulk free-radical polymerization of a styrene-type monomer.

## Materials:

- **2-Ethylstyrene** (inhibitor removed)
- Azobisisobutyronitrile (AIBN) (initiator)
- Nitrogen or Argon gas source
- Schlenk flask or reaction tube with a rubber septum
- Magnetic stirrer and stir bar
- Oil bath or heating mantle with temperature control
- Methanol (non-solvent for precipitation)
- Vacuum filtration apparatus
- Drying oven

## Procedure:

- **Monomer Purification:** Remove the inhibitor from **2-ethylstyrene** by passing it through a column of basic alumina.
- **Reaction Setup:** Place a magnetic stir bar in a clean, dry Schlenk flask. Add the desired amount of purified **2-ethylstyrene** and the initiator (e.g., AIBN, typically 0.1-1 mol% relative to the monomer).
- **Degassing:** Seal the flask with a rubber septum and deoxygenate the mixture by bubbling with nitrogen or argon for 15-20 minutes while stirring. Alternatively, perform three freeze-pump-thaw cycles.
- **Polymerization:** Immerse the flask in a preheated oil bath at the desired temperature (e.g., 60-80 °C).
- **Monitoring:** To determine reaction kinetics, withdraw samples at regular time intervals using a degassed syringe. Quench the polymerization in the sample by cooling and adding a small

amount of inhibitor (e.g., hydroquinone).

- **Analysis:** Determine the monomer conversion for each sample gravimetrically after precipitating the polymer in methanol, filtering, and drying. Analyze the molecular weight and polydispersity of the polymer samples by Gel Permeation Chromatography (GPC).
- **Termination and Isolation:** After the desired reaction time, cool the flask to room temperature to stop the polymerization. Dissolve the viscous polymer solution in a suitable solvent (e.g., toluene) and precipitate the polymer by slowly adding the solution to a stirred excess of a non-solvent (e.g., methanol).
- **Drying:** Collect the precipitated polymer by vacuum filtration and dry it in a vacuum oven at a moderate temperature until a constant weight is achieved.

## Anionic Polymerization

This protocol outlines the living anionic polymerization of a styrene-type monomer, which requires stringent anhydrous and anaerobic conditions.

Materials:

- **2-Ethylstyrene** (rigorously purified)
- Anhydrous tetrahydrofuran (THF) (solvent)
- sec-Butyllithium (s-BuLi) in cyclohexane (initiator)
- Methanol (terminating agent)
- High-vacuum line and glassware
- Magnetic stirrer and stir bar

Procedure:

- **Purification:** All glassware must be rigorously cleaned and flame-dried under vacuum. **2-Ethylstyrene** and THF must be purified to remove all traces of water and other protic

impurities. This is typically achieved by distillation from a suitable drying agent (e.g., sodium/benzophenone ketyl for THF, calcium hydride for the monomer).

- **Reaction Setup:** Assemble the reaction flask on a high-vacuum line. Introduce a magnetic stir bar and the desired amount of purified, anhydrous THF via cannula transfer under a positive pressure of inert gas.
- **Initiation:** Cool the solvent to the desired reaction temperature (e.g., -78 °C using a dry ice/acetone bath). Add a calculated amount of s-BuLi initiator via a gas-tight syringe. The appearance of a characteristic color (often orange or red for polystyryl anions) indicates the presence of active anionic centers.
- **Monomer Addition:** Slowly add the purified **2-ethylstyrene** to the initiator solution via a cannula. The polymerization is typically very fast.
- **Propagation:** Allow the reaction to proceed for the desired time. In a living polymerization, the reaction continues until all the monomer is consumed.
- **Termination:** Terminate the polymerization by adding a small amount of a protic agent, such as degassed methanol. The color of the solution will disappear upon termination.
- **Isolation and Analysis:** Precipitate the polymer in methanol, filter, and dry under vacuum. Analyze the polymer by GPC to determine the molecular weight and polydispersity. The polydispersity index (PDI) for a successful living anionic polymerization should be very low (typically < 1.1).

## Cationic Polymerization

This protocol provides a general procedure for the cationic polymerization of a styrene-type monomer. Cationic polymerizations are often rapid and sensitive to temperature and impurities.

Materials:

- **2-Ethylstyrene** (purified and dried)
- Dichloromethane (CH<sub>2</sub>Cl<sub>2</sub>) (dry, as solvent)
- Tin(IV) chloride (SnCl<sub>4</sub>) (initiator)

- Water or a protic acid (co-initiator)
- Methanol (terminating and precipitating agent)
- Inert atmosphere (nitrogen or argon)
- Dry glassware
- Low-temperature bath (e.g., ice-water or dry ice/acetone)

#### Procedure:

- **Purification:** The monomer and solvent must be thoroughly dried and purified to remove any water, which can act as a co-initiator in an uncontrolled manner.
- **Reaction Setup:** In a flame-dried, three-necked flask equipped with a stirrer, a nitrogen/argon inlet, and a septum, dissolve the purified **2-ethylstyrene** in dry dichloromethane.
- **Cooling:** Cool the solution to the desired polymerization temperature (e.g., 0 °C or -78 °C) using an appropriate cooling bath.
- **Initiation:** Prepare a solution of the initiator (e.g., SnCl<sub>4</sub>) in dichloromethane. Add the initiator solution dropwise to the cold, stirred monomer solution. A controlled amount of a co-initiator like water may be necessary to initiate the polymerization.
- **Polymerization:** The polymerization is often very rapid. Allow the reaction to proceed for the intended duration.
- **Termination:** Terminate the reaction by adding an excess of cold methanol.
- **Isolation and Analysis:** Precipitate the polymer by pouring the reaction mixture into a large volume of methanol. Collect the polymer by filtration, wash with fresh methanol, and dry under vacuum. Characterize the polymer using GPC.

## Visualizations

### General Free Radical Polymerization Workflow

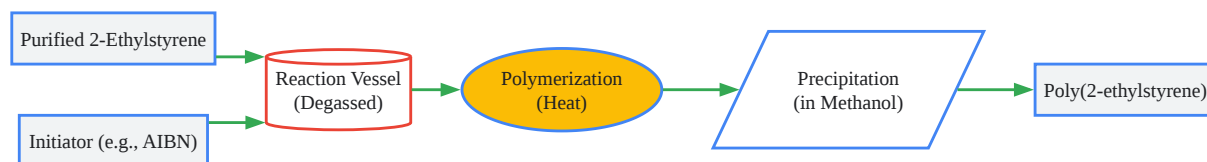

[Click to download full resolution via product page](#)

Caption: Workflow for free radical polymerization.

## Anionic Polymerization Logical Pathway

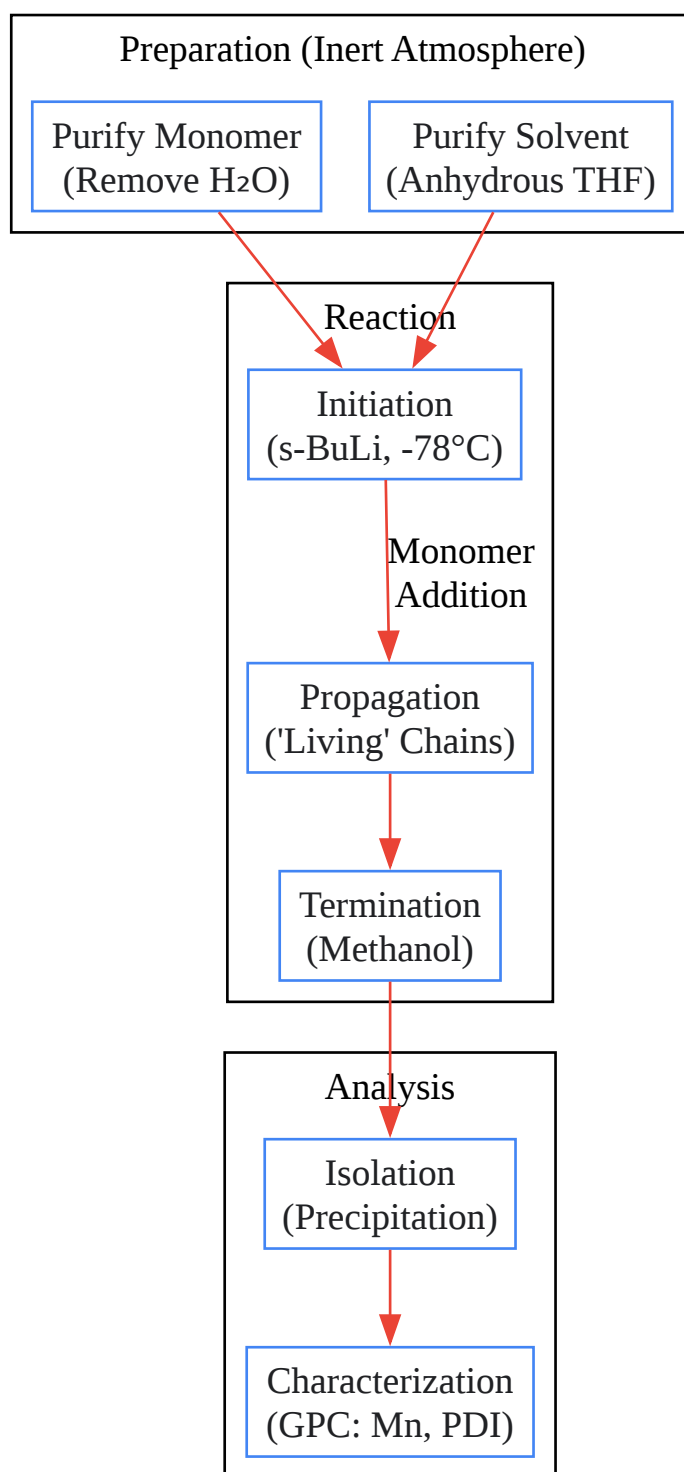

[Click to download full resolution via product page](#)

Caption: Key stages in anionic polymerization.

## Relationship of Polymerization Parameters

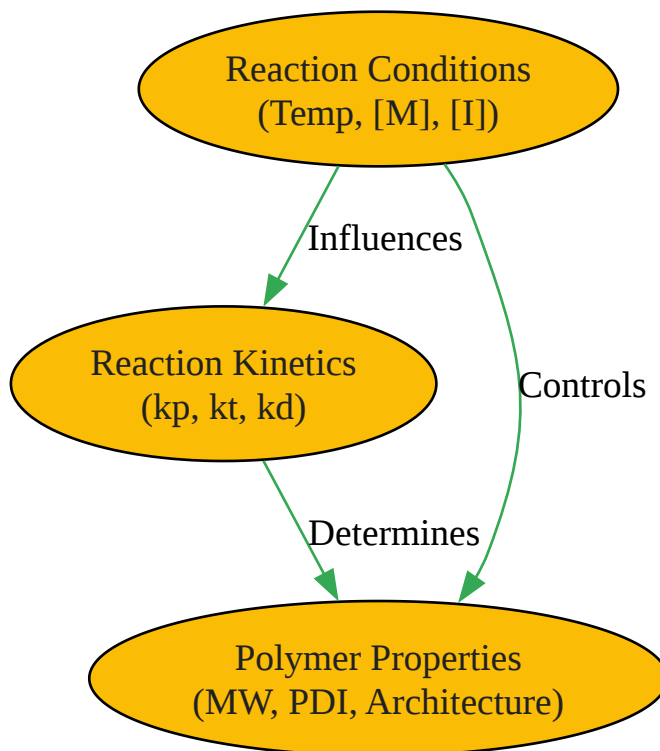

[Click to download full resolution via product page](#)

Caption: Interdependence of polymerization factors.

### Need Custom Synthesis?

BenchChem offers custom synthesis for rare earth carbides and specific isotopic labeling.

Email: [info@benchchem.com](mailto:info@benchchem.com) or [Request Quote Online](#).

## References

- 1. [polymer.chem.cmu.edu](http://polymer.chem.cmu.edu) [[polymer.chem.cmu.edu](http://polymer.chem.cmu.edu)]
- To cite this document: BenchChem. [Reaction Kinetics of 2-Ethylstyrene Polymerization: Application Notes and Protocols]. BenchChem, [2026]. [Online PDF]. Available at: [<https://www.benchchem.com/product/b3423024/docs#reaction-kinetics-of-2-ethylstyrene-polymerization-application-notes-and-protocols>]

**Disclaimer & Data Validity:**

The information provided in this document is for Research Use Only (RUO) and is strictly not intended for diagnostic or therapeutic procedures. While BenchChem strives to provide accurate protocols, we make no warranties, express or implied, regarding the fitness of this product for every specific experimental setup.

**Technical Support:** The protocols provided are for reference purposes. Unsure if this reagent suits your experiment?

**Need Industrial/Bulk Grade?** [Request Custom Synthesis Quote](#)

## BenchChem

Our mission is to be the trusted global source of essential and advanced chemicals, empowering scientists and researchers to drive progress in science and industry.

### Contact

Address: 3281 E Guasti Rd  
Ontario, CA 91761, United States  
Phone: (601) 213-4426  
Email: [info@benchchem.com](mailto:info@benchchem.com)

[Contact our Ph.D. Support Team for a compatibility check](#)