

Protocol for Utilizing Calcium Superphosphate in Hydroponic Nutrient Solutions

Author: BenchChem Technical Support Team. **Date:** May 2026

Compound of Interest

Compound Name: Calcium superphosphate

CAS No.: 301524-28-7

Cat. No.: B3423424

[Get Quote](#)

For Researchers, Scientists, and Drug Development Professionals

Introduction

Calcium superphosphate, a common agricultural fertilizer, can serve as a source of both phosphorus and calcium in hydroponic nutrient solutions. However, its application in soilless culture requires careful management to prevent the precipitation of calcium phosphates, which can lead to nutrient deficiencies and clog irrigation systems. This document provides detailed application notes and protocols for the successful incorporation of **calcium superphosphate** into hydroponic nutrient solutions for research and development purposes.

The two primary forms of **calcium superphosphate** are Single Superphosphate (SSP) and Triple Superphosphate (TSP). SSP is primarily composed of monocalcium phosphate ($\text{Ca}(\text{H}_2\text{PO}_4)_2$) and gypsum (calcium sulfate - $\text{CaSO}_4 \cdot 2\text{H}_2\text{O}$), while TSP consists mainly of monocalcium phosphate.^{[1][2]} The monocalcium phosphate component is the primary water-soluble source of phosphate.

A critical factor in using **calcium superphosphate** in hydroponics is the pH of the nutrient solution. The optimal pH range for most hydroponic crops is between 5.5 and 6.5 to ensure the availability of all essential nutrients.^{[3][4]} However, at a pH above 6.2, the risk of calcium and phosphate precipitating as insoluble dicalcium phosphate or other calcium phosphate compounds significantly increases.^{[5][6]}

Data Presentation

Chemical Composition of Calcium Superphosphates

Fertilizer Type	Primary Components	Phosphorus (P ₂ O ₅) Content (%)	Calcium (Ca) Content (%)	Sulfur (S) Content (%)
Single Superphosphate (SSP)	Monocalcium phosphate (Ca(H ₂ PO ₄) ₂ ·H ₂ O), Calcium sulfate (CaSO ₄ ·2H ₂ O)	16-22	18-21	11-12
Triple Superphosphate (TSP)	Monocalcium phosphate (Ca(H ₂ PO ₄) ₂)	43-48	12-14	1-3

Solubility of Monocalcium Phosphate in Water

The solubility of monocalcium phosphate, the active ingredient in superphosphate, is highly dependent on pH. While highly soluble in acidic conditions, its stability decreases as the pH approaches the typical hydroponic range. In aqueous solutions with a pH between approximately 2 and 5, dicalcium phosphates (e.g., brushite) are the more stable phases, leading to the precipitation of calcium and phosphate.

pH	Temperature (°C)	Approximate Solubility of Monocalcium Phosphate (g/L)	Remarks
< 2.0	25	High	Stable as monocalcium phosphate.
5.5	25	Limited	Increased risk of conversion to less soluble dicalcium phosphate.
6.0	25	Limited	Higher risk of precipitation compared to pH 5.5.
6.5	25	Very Limited	Significant risk of calcium phosphate precipitation.[6]

Recommended Nutrient Concentrations in Hydroponic Solutions

Nutrient	Concentration Range (ppm)
Calcium (Ca)	150 - 250
Phosphorus (P)	30 - 50

Experimental Protocols

Protocol for Preparing a Hydroponic Nutrient Solution Using a Three-Part Stock System with Superphosphate

Due to the incompatibility of concentrated calcium and phosphate, a three-part stock solution is recommended when using superphosphate. This method separates the calcium source, the phosphate source (from superphosphate), and the remaining sulfates and micronutrients.

Materials:

- Triple Superphosphate (TSP) (preferred for higher purity and no gypsum)
- Calcium Nitrate ($\text{Ca}(\text{NO}_3)_2$)
- Potassium Nitrate (KNO_3)
- Potassium Sulfate (K_2SO_4)
- Magnesium Sulfate (MgSO_4)
- Micronutrient chelate mix
- Phosphoric Acid (H_3PO_4) (for pH adjustment and pre-dissolving)
- Three separate, opaque stock solution containers (labeled A, B, and C)
- Accurate scale (grams)
- pH meter
- EC/TDS meter
- Reverse osmosis (RO) or distilled water

Procedure:

Part A: Calcium Stock Solution

- Fill the "A" container to 80% of its final volume with RO or distilled water.
- Dissolve the required amount of Calcium Nitrate.
- If necessary, add a portion of the Potassium Nitrate to this solution.
- Add chelated iron if it is separate from the micronutrient mix.
- Top up to the final volume with water and mix thoroughly.

Part B: Sulfate and Micronutrient Stock Solution

- Fill the "B" container to 80% of its final volume with RO or distilled water.
- Dissolve Potassium Sulfate and Magnesium Sulfate.
- Add the micronutrient chelate mix (ensure it does not contain significant amounts of unchelated iron that could react with phosphates).
- Add the remaining Potassium Nitrate.
- Top up to the final volume with water and mix thoroughly.

Part C: Superphosphate Stock Solution (Acidified)

- Pre-dissolving the Superphosphate: In a separate container, create a dilute acidic solution by adding a small amount of phosphoric acid to RO or distilled water, aiming for a pH below 4.0. This acidic environment will aid in the dissolution of the monocalcium phosphate and inhibit early precipitation.
- Slowly add the calculated amount of Triple Superphosphate to the acidic water while stirring vigorously. Continue stirring until the superphosphate is fully dissolved. Some insoluble impurities may remain, which can be allowed to settle.
- Carefully decant the clear, dissolved superphosphate solution into the "C" stock container, leaving any sediment behind.
- Top up the "C" container to its final volume with RO or distilled water.
- Measure the pH of the final Part C solution. It should remain acidic.

Final Nutrient Solution Preparation:

- Fill the main nutrient reservoir with the final volume of RO or distilled water.
- Add the required volume of Stock Solution A and mix well.
- Add the required volume of Stock Solution B and mix well.

- Crucially, add Stock Solution C last and slowly while the reservoir solution is being agitated. This ensures that the phosphate is rapidly diluted, minimizing the risk of precipitation with the calcium from Stock Solution A.
- After all stock solutions are added and thoroughly mixed, check and adjust the final pH of the nutrient solution to the target range (typically 5.5-6.5).[3] Use a pH down (like dilute phosphoric acid) or pH up (like potassium hydroxide) solution for adjustments.
- Check the Electrical Conductivity (EC) or Total Dissolved Solids (TDS) of the final solution and adjust if necessary by adding more of the three-part stock solutions in the correct ratio or by diluting with water.

Mandatory Visualizations

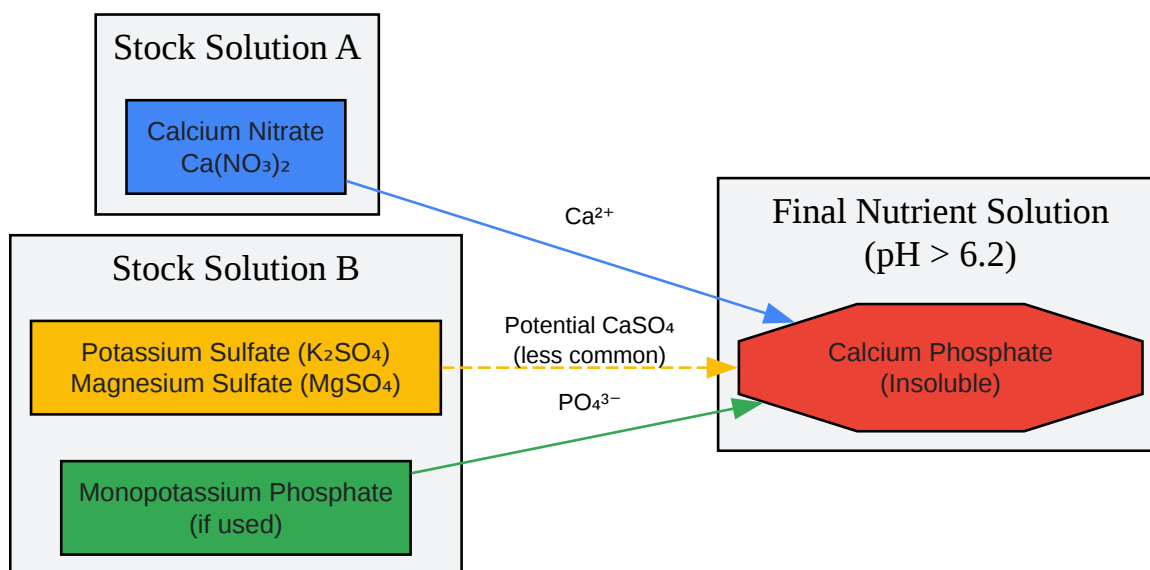

Incompatible ions in concentrated solutions.

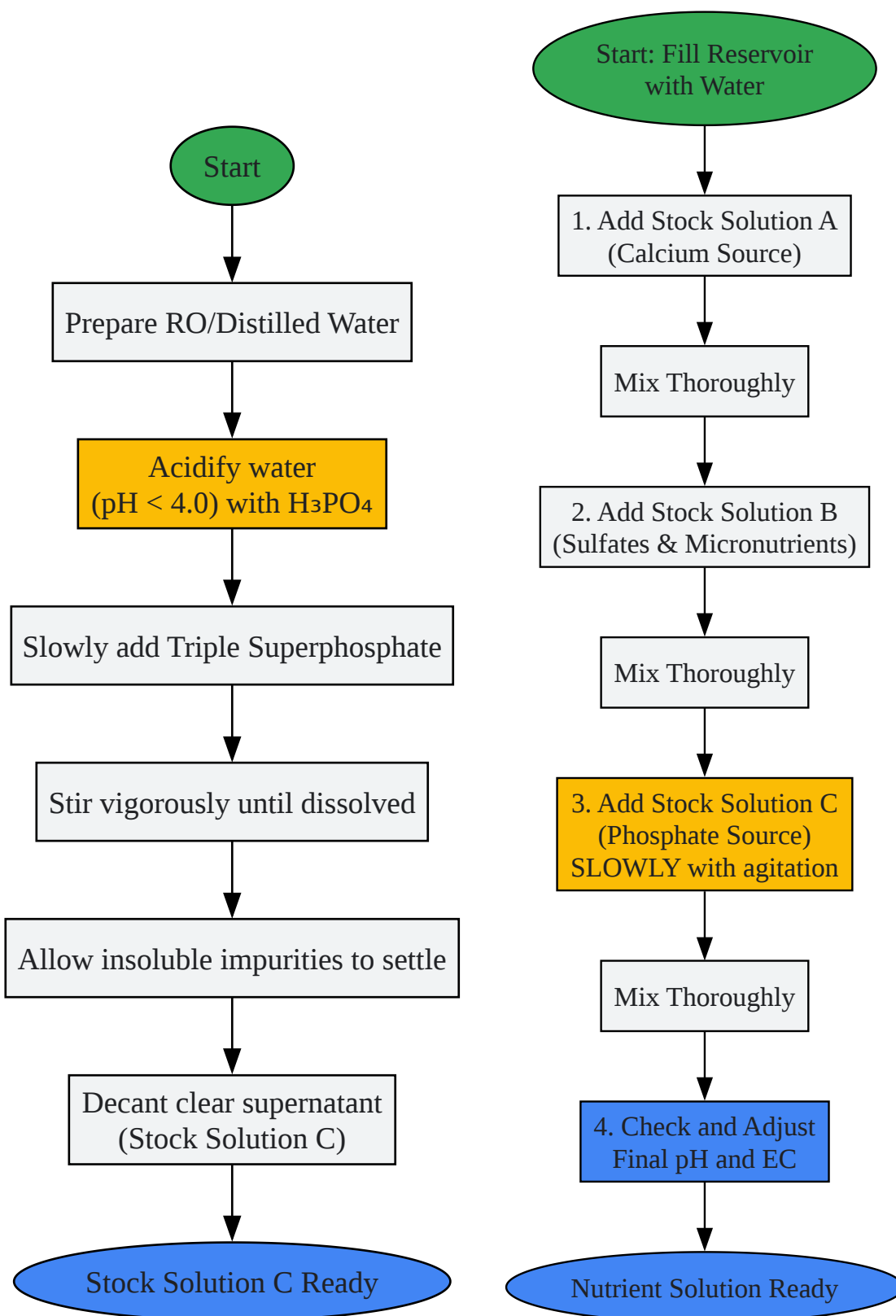

[Click to download full resolution via product page](#)

Need Custom Synthesis?

BenchChem offers custom synthesis for rare earth carbides and specific isotopic labeling.

Email: info@benchchem.com or [Request Quote Online](#).

References

- [1. nvlpubs.nist.gov \[nvlpubs.nist.gov\]](https://nvlpubs.nist.gov)
- [2. Fertilizer superphosphate: instructions for use in the garden \[gardenguide.decorexpro.com\]](https://gardenguide.decorexpro.com)
- [3. m.youtube.com \[m.youtube.com\]](https://m.youtube.com)
- [4. gardenculturemagazine.com \[gardenculturemagazine.com\]](https://gardenculturemagazine.com)
- [5. frontrowag.com \[frontrowag.com\]](https://frontrowag.com)
- [6. Hydroponic Nutrient Lockout: Causes, Symptoms, and How to Prevent It - Eutrema \[eutrema.co.uk\]](https://eutrema.co.uk)
- To cite this document: BenchChem. [Protocol for Utilizing Calcium Superphosphate in Hydroponic Nutrient Solutions]. BenchChem, [2026]. [Online PDF]. Available at: [\[https://www.benchchem.com/product/b3423424/docs#protocol-for-utilizing-calcium-superphosphate-in-hydroponic-nutrient-solutions\]](https://www.benchchem.com/product/b3423424/docs#protocol-for-utilizing-calcium-superphosphate-in-hydroponic-nutrient-solutions)

Disclaimer & Data Validity:

The information provided in this document is for Research Use Only (RUO) and is strictly not intended for diagnostic or therapeutic procedures. While BenchChem strives to provide accurate protocols, we make no warranties, express or implied, regarding the fitness of this product for every specific experimental setup.

Technical Support: The protocols provided are for reference purposes. Unsure if this reagent suits your experiment?

Need Industrial/Bulk Grade? [Request Custom Synthesis Quote](#)

BenchChem

Our mission is to be the trusted global source of essential and advanced chemicals, empowering scientists and researchers to drive progress in science and industry.

Contact

Address: 3281 E Guasti Rd

Ontario, CA 91761, United States

Phone: (601) 213-4426

Email: info@benchchem.com

[Contact our Ph.D. Support Team for a compatibility check](#)