

# interpreting mass spectrometry fragmentation patterns of 2-phenyl-2-butene

**Author:** BenchChem Technical Support Team. **Date:** April 2026

## Compound of Interest

Compound Name: 2-Phenyl-2-butene

CAS No.: 2082-61-3

Cat. No.: B3421063

[Get Quote](#)

## Technical Support Center: Mass Spectrometry Analysis of 2-Phenyl-2-butene

This guide provides troubleshooting advice and frequently asked questions regarding the interpretation of mass spectrometry fragmentation patterns for **2-phenyl-2-butene**.

### Frequently Asked Questions (FAQs)

**Q1:** What are the expected major peaks in the electron ionization (EI) mass spectrum of **2-phenyl-2-butene**?

**A1:** In a typical 70 eV EI mass spectrum of **2-phenyl-2-butene**, you should expect to see several key fragments. The molecular ion peak ( $M^+$ ) will appear at a mass-to-charge ratio ( $m/z$ ) corresponding to the molecular weight of the compound. The most abundant fragments often result from the loss of small alkyl radicals and rearrangements that form stable carbocations.

**Q2:** I see a peak at  $m/z$  132 in my spectrum. What is it?

A2: A peak at  $m/z$  132 corresponds to the molecular ion ( $M^+$ ) of **2-phenyl-2-butene** ( $C_{10}H_{12}$ ). [1] The presence of a clear molecular ion peak is common for aromatic compounds due to the stability of the benzene ring.[2]

Q3: My spectrum shows a significant peak at  $m/z$  117. What fragmentation does this represent?

A3: The peak at  $m/z$  117 is a result of the loss of a methyl radical ( $\bullet CH_3$ ), which has a mass of 15 amu, from the molecular ion ( $132 - 15 = 117$ ).[1] This is a common fragmentation pathway for compounds containing methyl groups, as it leads to the formation of a stable secondary carbocation.

Q4: Why is there a prominent peak at  $m/z$  91?

A4: The peak at  $m/z$  91 is a hallmark of many alkyl-substituted benzene compounds.[2] It is attributed to the formation of the highly stable tropylium ion ( $C_7H_7^+$ ). This occurs through a rearrangement of the benzyl cation, which is initially formed by cleavage of the bond beta to the phenyl group.

Q5: I am not seeing a clear molecular ion peak at  $m/z$  132. What could be the issue?

A5: While aromatic compounds typically show a distinct molecular ion peak, its intensity can be reduced under certain conditions. High ionization energy or a very hot ion source can lead to extensive fragmentation, diminishing the  $M^+$  peak. Consider reducing the ionization energy if your instrument allows, or checking the temperature of the ion source. Also, verify the purity of your sample, as impurities can complicate the spectrum.

Q6: Are there other minor peaks I should expect to see?

A6: Yes, you may observe other smaller fragments. For instance, the loss of an ethyl radical ( $\bullet C_2H_5$ ) from the molecular ion would result in a peak at  $m/z$  103. Further fragmentation of the primary ions can also lead to a variety of smaller fragments, though their intensity is generally low.

## Troubleshooting Guide

Issue	Possible Cause	Suggested Solution
No molecular ion peak (m/z 132) observed.	High ionization energy causing excessive fragmentation.	If possible, lower the ionization energy (e.g., to 20 eV) to favor the formation of the molecular ion.
Ion source temperature is too high.	Check and lower the ion source temperature to reduce thermal degradation and excessive fragmentation.	
Sample is impure.	Purify the sample using appropriate techniques (e.g., distillation, chromatography) and re-run the analysis.	
Unexpected peaks in the spectrum.	Contamination from the solvent, GC column bleed, or sample handling.	Run a blank to identify background peaks. Ensure proper sample handling and use high-purity solvents.
Presence of isomers.	Isomers of 2-phenyl-2-butene may co-elute and produce overlapping mass spectra. Optimize your GC method to improve separation.	
Incorrect relative abundances of major fragments.	Different ionization method used (e.g., Chemical Ionization - CI).	Confirm that you are using Electron Ionization (EI) for fragmentation analysis. CI is a softer ionization technique and will produce significantly less fragmentation.
Instrument settings (e.g., detector voltage, scan speed).	Ensure that the mass spectrometer is properly tuned and calibrated according to the manufacturer's recommendations.	

## Data Presentation

### Key Fragmentation Data for 2-Phenyl-2-butene

m/z	Proposed Fragment Ion	Neutral Loss	Mass of Neutral Loss (amu)
132	[C <sub>10</sub> H <sub>12</sub> ] <sup>+•</sup> (Molecular Ion)	-	0
117	[C <sub>9</sub> H <sub>9</sub> ] <sup>+</sup>	•CH <sub>3</sub>	15
91	[C <sub>7</sub> H <sub>7</sub> ] <sup>+</sup> (Tropylium ion)	•C <sub>3</sub> H <sub>5</sub>	41

## Experimental Protocols

### Gas Chromatography-Mass Spectrometry (GC-MS) of 2-Phenyl-2-butene

This protocol outlines a general procedure for the analysis of **2-phenyl-2-butene** using GC-MS with electron ionization.

- Sample Preparation:
  - Dissolve a small amount of **2-phenyl-2-butene** in a volatile organic solvent (e.g., dichloromethane or hexane) to a final concentration of approximately 100 µg/mL.
- GC-MS System and Conditions:
  - Gas Chromatograph: Agilent 7890B or equivalent.
  - Mass Spectrometer: Agilent 5977A or equivalent single quadrupole mass spectrometer.
  - Injector: Split/splitless injector, typically operated in split mode (e.g., 50:1 split ratio) at 250°C.
  - Carrier Gas: Helium at a constant flow rate of 1.0 mL/min.

- GC Column: A non-polar or medium-polarity column is suitable, such as a 30 m x 0.25 mm ID x 0.25  $\mu$ m film thickness HP-5ms or DB-5ms.
- Oven Temperature Program:
  - Initial temperature: 50°C, hold for 2 minutes.
  - Ramp: Increase temperature at a rate of 10°C/min to 280°C.
  - Final hold: Hold at 280°C for 5 minutes.
- Mass Spectrometer Conditions:
  - Ion Source: Electron Ionization (EI) at 70 eV.
  - Ion Source Temperature: 230°C.
  - Quadrupole Temperature: 150°C.
  - Scan Range: m/z 40-400.
  - Solvent Delay: 3 minutes (to prevent the solvent peak from damaging the detector).
- Data Acquisition and Analysis:
  - Inject 1  $\mu$ L of the prepared sample into the GC-MS system.
  - Acquire the data using the instrument's software.
  - Identify the peak corresponding to **2-phenyl-2-butene** in the total ion chromatogram (TIC).
  - Extract and analyze the mass spectrum of this peak.
  - Compare the obtained spectrum with a reference library (e.g., NIST) and interpret the fragmentation pattern based on the principles outlined in this guide.

## Mandatory Visualization

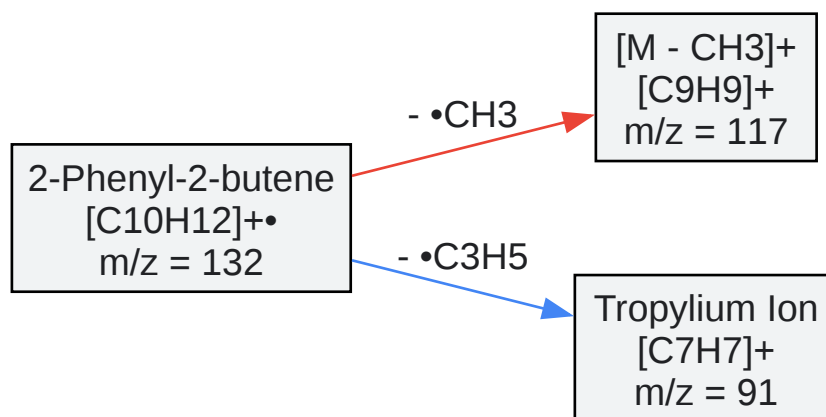

[Click to download full resolution via product page](#)

Caption: Fragmentation pathway of **2-phenyl-2-butene** in EI-MS.

### Need Custom Synthesis?

BenchChem offers custom synthesis for rare earth carbides and specific isotopic labeling.

Email: [info@benchchem.com](mailto:info@benchchem.com) or [Request Quote Online](#).

## References

- 1. [cis-2-Phenyl-2-butene | C<sub>10</sub>H<sub>12</sub> | CID 5358306 - PubChem \[pubchem.ncbi.nlm.nih.gov\]](#)
- 2. [whitman.edu \[whitman.edu\]](#)
- To cite this document: BenchChem. [interpreting mass spectrometry fragmentation patterns of 2-phenyl-2-butene]. BenchChem, [2026]. [Online PDF]. Available at: [\[https://www.benchchem.com/product/b3421063/docs#interpreting-mass-spectrometry-fragmentation-patterns-of-2-phenyl-2-butene\]](https://www.benchchem.com/product/b3421063/docs#interpreting-mass-spectrometry-fragmentation-patterns-of-2-phenyl-2-butene)

### Disclaimer & Data Validity:

The information provided in this document is for Research Use Only (RUO) and is strictly not intended for diagnostic or therapeutic procedures. While BenchChem strives to provide accurate protocols, we make no warranties, express or implied, regarding the fitness of this product for every specific experimental setup.

**Technical Support:** The protocols provided are for reference purposes. Unsure if this reagent suits your experiment?

**Need Industrial/Bulk Grade?** [Request Custom Synthesis Quote](#)

## BenchChem

Our mission is to be the trusted global source of essential and advanced chemicals, empowering scientists and researchers to drive progress in science and industry.

### Contact

Address: 3281 E Guasti Rd  
Ontario, CA 91761, United States  
Phone: (601) 213-4426  
Email: [info@benchchem.com](mailto:info@benchchem.com)

[Contact our Ph.D. Support Team for a compatibility check](#)