

# A Comparative Guide to the Catalytic Activity of Chromium(III) Acetate Complexes

**Author:** BenchChem Technical Support Team. **Date:** April 2026

## Compound of Interest

Compound Name: Chromium(III) acetate

CAS No.: 17593-70-3

Cat. No.: B3420162

[Get Quote](#)

For Researchers, Scientists, and Drug Development Professionals

This guide provides an objective comparison of the catalytic performance of **chromium(III) acetate** and its derivatives, primarily focusing on their well-documented application in olefin polymerization. We will also touch upon their role in oxidation reactions and present supporting experimental data and protocols to offer a comprehensive assessment for research and development purposes.

## Introduction to Chromium(III) Acetate as a Catalyst

**Chromium(III) acetate**, often referred to as basic chromium acetate, is a coordination compound with the formula  $[\text{Cr}_3\text{O}(\text{O}_2\text{CCH}_3)_6(\text{OH}_2)_3]^+$ .<sup>[1]</sup> Its unique trinuclear oxo-centered structure is foundational to its catalytic properties.<sup>[1]</sup> While Cr(III) compounds are generally considered less toxic than their hazardous Cr(VI) counterparts, their catalytic applications are extensive, ranging from use as mordants in the textile industry to catalysts for olefin polymerization and oxidation reactions.<sup>[2][3]</sup> The versatility of chromium as a catalyst stems from its ability to exist in multiple oxidation states, though the +3 state is one of the most stable.<sup>[3]</sup>

## Performance in Olefin Polymerization

Chromium-based catalysts, including **chromium(III) acetate** derivatives, are significant in the industrial production of polyethylene.<sup>[4]</sup> They are often used in Ziegler-Natta type systems, typically requiring activation by a co-catalyst such as an organoaluminum compound (e.g., diethylaluminum chloride or methylaluminoxane (MAO)).<sup>[5][6]</sup>

## Comparative Catalytic Activity Data

The following table summarizes the performance of various chromium(III) carboxylate complexes in ethylene polymerization and compares them with other catalyst systems.

Catalyst System	Co-catalyst / Activator	Temperature (°C)	Pressure (atm)	Catalytic Activity	Polymer Characteristics
Chromium(III) Acetate Derivative					
[Cr <sub>3</sub> O(CICH <sub>2</sub> COO) <sub>6</sub> ·3H <sub>2</sub> O]NO <sub>3</sub> ·3H <sub>2</sub> O (Chromium(III) monochloroacetate)[5][7]	Diethylaluminum chloride	29	~1	1768 g PE / g Cr / hr / atm	High density, high crystallinity[5]
Chromium(III) dichloroacetate[5]	Diethylaluminum chloride	-	-	Lower activity than monochloroacetate derivative[5]	-
Chromium(III) trichloroacetate[5]	Diethylaluminum chloride	-	-	Lower activity than monochloroacetate derivative[5]	-
Chromium(III) acetate[5]	Diethylaluminum chloride	-	-	Lower activity than monochloroacetate derivative[5]	-
Other Chromium-Based Catalysts					

Cr(III) complex with donor- functionalized cyclopentadie nyl ligand (Cr <sub>2</sub> (THF))[6]	MAO (200 equiv.)	100	-	1.01 x 10 <sup>8</sup> g PE / mol Cr / hr	High molecular weight (24.6 x 10 <sup>4</sup> g/mol ) [6]
Cr(III)-MFU-4l (Metal- Organic Framework) [8]	AlMe <sub>3</sub>	Room Temp.	40 bar	52,000 mol Ethylene / mol Cr / hr	Low polydispersity (1.36), granular morphology[8 ]
Alternative Catalyst Systems					
Ziegler-Natta (TiCl <sub>4</sub> /MgCl <sub>2</sub> ) - Method A[9] [10]	Triethylalumin um	-	-	Higher activity than Method B catalyst[9][10]	Similar polymer properties to Method B[10]
Ziegler-Natta (TiCl <sub>4</sub> /Mg(OEt ) <sub>2</sub> ) - Method B[9][10]	Triethylalumin um	-	-	Lower activity than Method A catalyst[9] [10]	Similar polymer properties to Method A[10]

PE: Polyethylene; MAO: Methylaluminoxane

The data indicates that ligand modification on the chromium carboxylate complex significantly impacts catalytic activity. For instance, the monochloroacetate derivative shows substantially higher activity compared to the unsubstituted **chromium(III) acetate**. [5][7] This is likely due to the electronic effects of the chloro-substituent groups on the carboxylate ligand. [5]

Furthermore, advanced systems using specialized ligands or supports like metal-organic frameworks (MOFs) can achieve exceptionally high activities. [6][8]

## Performance in Oxidation Reactions

Chromium compounds are well-known oxidation catalysts.[2] While highly effective, many traditional methods employ toxic and environmentally hazardous hexavalent chromium (Cr(VI)) reagents.[11][12] Research into greener alternatives is ongoing. **Chromium(III) acetate** itself is listed as an oxidation catalyst, though specific quantitative performance data in comparison to alternatives is less prevalent in the reviewed literature than for polymerization.[2]

Alternatives to Chromium-based Oxidation:

- Selenium and Peroxy-reagents: Often used for allylic oxidations but can be hazardous and challenging to scale up.[11]
- N-bromosuccinimide (NBS): A chromium-free alternative demonstrated to successfully perform allylic oxidation, yielding enones in over 90% yield under optimized conditions.[11]
- Other Transition Metals: Nickel, Ruthenium, and Manganese-based catalysts are being developed for various oxidation reactions, offering potentially greener and more selective routes.[13] For example, a graphene-MnO<sub>2</sub> catalyst has been developed for the oxidation of formaldehyde.[13]

## Experimental Protocols

### Catalyst Preparation and Activation

This protocol is a generalized procedure for ethylene polymerization using a chromium(III) carboxylate catalyst system.

Materials:

- Chromium(III) carboxylate complex (e.g.,  $[\text{Cr}_3\text{O}(\text{ClCH}_2\text{COO})_6 \cdot 3\text{H}_2\text{O}]\text{NO}_3 \cdot 3\text{H}_2\text{O}$ )[7]
- Toluene (anhydrous)
- Diethylaluminum chloride (cocatalyst)[7]
- Ethylene gas (polymerization grade)

- Nitrogen gas (high purity)

#### Procedure:

- **Reactor Setup:** A glass-lined autoclave reactor equipped with a mechanical stirrer, temperature control, and gas inlet/outlet lines is used. The reactor is thoroughly dried and purged with nitrogen to ensure an inert atmosphere.[14]
- **Catalyst Slurry Preparation:** In a separate Schlenk flask under nitrogen, a specific amount of the chromium complex (e.g., 0.02 g) is mixed with anhydrous toluene (e.g., 87 mL).[7]
- **Co-catalyst Addition:** The required volume of diethylaluminum chloride (e.g., 13 mL) is added to the toluene to act as a cocatalyst and scavenger. The Al/Cr molar ratio is a critical parameter to optimize; a ratio of 30.8 was found to be optimal in one study.[7]
- **Catalyst Aging:** The mixture of the chromium complex and cocatalyst is stirred and left to 'age' for a set period (e.g., 15 minutes) to allow for the formation of the active catalytic species.[7]
- **Transfer to Reactor:** The aged catalyst slurry is then transferred to the prepared reactor under a nitrogen blanket.

## Ethylene Polymerization

- **Pressurization:** The reactor is pressurized with ethylene to the desired reaction pressure (e.g., ~1 atm). Ethylene is supplied on demand to maintain constant pressure throughout the reaction.[7][15]
- **Reaction:** The polymerization is carried out at a controlled temperature (e.g., 29°C) for a specified duration (e.g., 60 minutes).[7] The catalytic activity can be highly sensitive to temperature.[7]
- **Termination:** After the designated time, the ethylene feed is stopped, and the reactor is vented and cooled to room temperature.
- **Polymer Recovery:** The resulting polyethylene is recovered from the reactor, washed (e.g., with acidified ethanol to remove catalyst residues), filtered, and dried under vacuum to a

constant weight.

## Product Characterization

- **Catalytic Activity Calculation:** The activity is calculated based on the mass of the polymer produced, the amount of chromium used, the reaction time, and the ethylene pressure. The unit is typically grams of polyethylene per gram of chromium per hour per atmosphere (g PE/g Cr/hr/atm).[5]
- **Polymer Analysis:** The obtained polyethylene is characterized using various analytical techniques:
  - **FT-IR Spectroscopy:** To confirm the chemical structure of the polymer.[7]
  - **Differential Scanning Calorimetry (DSC):** To determine melting point ( $T_m$ ) and crystallinity. [7]
  - **Gel Permeation Chromatography (GPC):** To determine the molecular weight and molecular weight distribution (polydispersity index, PDI).[15]

## Visualizing the Experimental Workflow

The following diagrams illustrate the logical flow of assessing catalyst performance and a simplified representation of the catalytic polymerization cycle.

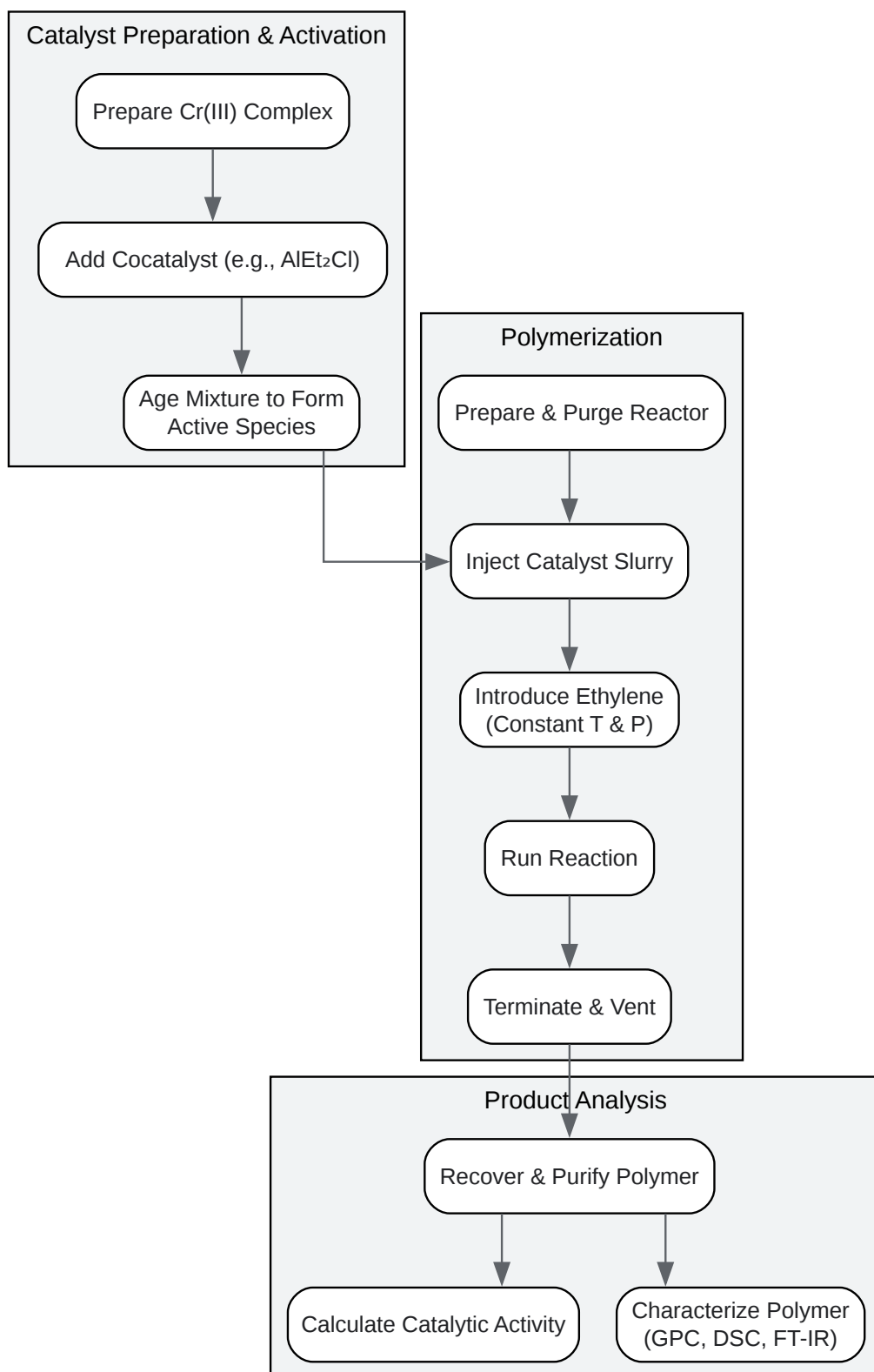

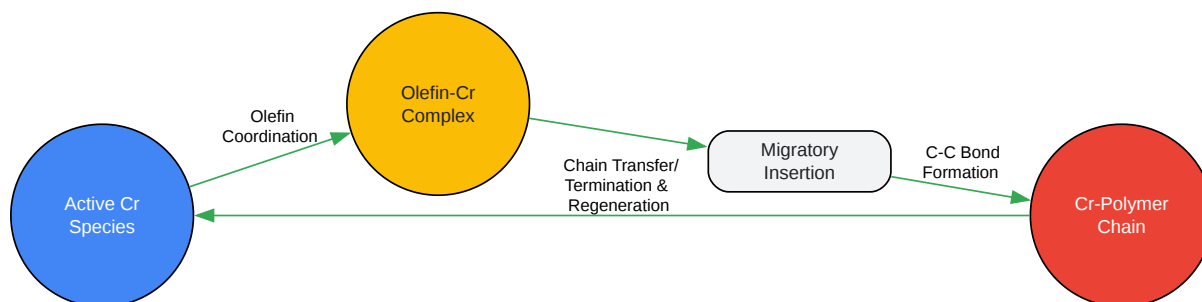

[Click to download full resolution via product page](#)

### Need Custom Synthesis?

BenchChem offers custom synthesis for rare earth carbides and specific isotopic labeling.

Email: [info@benchchem.com](mailto:info@benchchem.com) or [Request Quote Online](#).

## References

- [1. Chromium\(III\) acetate - Wikipedia \[en.wikipedia.org\]](#)
- [2. Chromium\(III\) acetate | C6H9CrO6 | CID 14012 - PubChem \[pubchem.ncbi.nlm.nih.gov\]](#)
- [3. books.rsc.org \[books.rsc.org\]](#)
- [4. cris.iucc.ac.il \[cris.iucc.ac.il\]](#)
- [5. researchgate.net \[researchgate.net\]](#)
- [6. researchgate.net \[researchgate.net\]](#)
- [7. scispace.com \[scispace.com\]](#)
- [8. pubs.acs.org \[pubs.acs.org\]](#)
- [9. engj.org \[engj.org\]](#)
- [10. engj.org \[engj.org\]](#)
- [11. scientificupdate.com \[scientificupdate.com\]](#)
- [12. google.com \[google.com\]](#)

- [13. royalsocietypublishing.org \[royalsocietypublishing.org\]](https://royalsocietypublishing.org)
- [14. researchgate.net \[researchgate.net\]](https://researchgate.net)
- [15. data.epo.org \[data.epo.org\]](https://data.epo.org)
- To cite this document: BenchChem. [A Comparative Guide to the Catalytic Activity of Chromium(III) Acetate Complexes]. BenchChem, [2026]. [Online PDF]. Available at: [<https://www.benchchem.com/product/b3420162/docs#a-comparative-guide-to-the-catalytic-activity-of-chromium-iii-acetate-complexes>]

---

### Disclaimer & Data Validity:

The information provided in this document is for Research Use Only (RUO) and is strictly not intended for diagnostic or therapeutic procedures. While BenchChem strives to provide accurate protocols, we make no warranties, express or implied, regarding the fitness of this product for every specific experimental setup.

**Technical Support:** The protocols provided are for reference purposes. Unsure if this reagent suits your experiment?

**Need Industrial/Bulk Grade?** [Request Custom Synthesis Quote](#)

## BenchChem

Our mission is to be the trusted global source of essential and advanced chemicals, empowering scientists and researchers to drive progress in science and industry.

### Contact

Address: 3281 E Guasti Rd  
Ontario, CA 91761, United States  
Phone: (601) 213-4426  
Email: [info@benchchem.com](mailto:info@benchchem.com)

[Contact our Ph.D. Support Team for a compatibility check](#)

