

# Physicochemical Profile & Synthetic Utility of 2-Chlorobenzyl Isocyanide

**Author:** BenchChem Technical Support Team. **Date:** April 2026

## Compound of Interest

Compound Name: 2-Chlorobenzylisocyanide

CAS No.: 602261-91-6

Cat. No.: B3416100

[Get Quote](#)

## Executive Summary

2-Chlorobenzyl isocyanide (CAS: 602261-91-6) is a specialized C1 building block primarily utilized in isocyanide-based multicomponent reactions (IMCRs) such as the Ugi and Passerini reactions. Distinguished by the electron-withdrawing and sterically demanding ortho-chloro substituent, this compound offers unique reactivity profiles compared to its unsubstituted benzyl analogues. It serves as a critical intermediate in the synthesis of peptidomimetics, heterocycles (e.g., oxazoles, tetrazoles), and functionalized pharmaceutical scaffolds.

This guide provides a rigorous technical analysis of its physicochemical properties, a self-validating synthesis protocol, and handling procedures designed to mitigate the notorious olfactory challenges associated with isocyanides.

## Chemical Identity & Physicochemical Properties[1] [2][3][4][5][6][7][8]

Note on Isomerism: Researchers must rigorously distinguish between the isocyanide (-NC, isonitrile) and the isomeric nitrile (-CN, cyanide). The physicochemical behaviors—particularly

odor and toxicity—are vastly different.

**Table 1: Physicochemical Specifications**

Property	Specification	Notes
IUPAC Name	1-Chloro-2-(isocyanomethyl)benzene	
CAS Number	602261-91-6	Distinct from 2-chlorobenzyl cyanide (2856-63-5)
Molecular Formula	C <sub>8</sub> H <sub>6</sub> ClN	
Molecular Weight	151.59 g/mol	
Physical State	Colorless to pale yellow liquid	Darkens upon storage if not stabilized
Boiling Point	~90–95 °C @ 1–2 mmHg (Est.)	Decomposes/polymerizes at atmospheric pressure >150°C
Density	~1.18 – 1.20 g/mL	Estimated based on 4-Cl analog trends
Solubility	Soluble in DCM, THF, MeOH, Et <sub>2</sub> O	Hydrolyzes slowly in aqueous acid
Odor	Extremely Pungent / Vile	Detectable at ppb levels; requires dedicated handling

## Spectroscopic Signature[3][9]

- Infrared (IR): The diagnostic -N≡C stretch appears at ~2150 cm<sup>-1</sup>. This band is strong and distinct from the nitrile stretch (~2250 cm<sup>-1</sup>) and isocyanate stretch (~2270 cm<sup>-1</sup>).
- <sup>1</sup>H NMR (CDCl<sub>3</sub>): The benzylic methylene protons (-CH<sub>2</sub>-NC) typically appear as a singlet or a poorly resolved triplet (due to <sup>14</sup>N coupling) at δ 4.70 – 4.80 ppm. The ortho-chloro group causes a slight downfield shift relative to benzyl isocyanide (δ 4.60 ppm).
- <sup>13</sup>C NMR: The terminal isocyanide carbon exhibits a characteristic 1:1:1 triplet at ~158 ppm (J<sub>CN</sub> ≈ 6–7 Hz) due to coupling with the quadrupolar <sup>14</sup>N nucleus.

## Self-Validating Synthesis Protocol

While commercially available, in situ preparation or lab-scale synthesis is often preferred to ensure purity, as isocyanides degrade via oxidation and polymerization. The most robust method is the dehydration of the corresponding formamide.

### Reaction Pathway

The synthesis proceeds in two stages:[\[1\]](#)[\[2\]](#)[\[3\]](#)

- Formylation: 2-Chlorobenzylamine

N-(2-chlorobenzyl)formamide.

- Dehydration: N-(2-chlorobenzyl)formamide

2-Chlorobenzyl isocyanide.

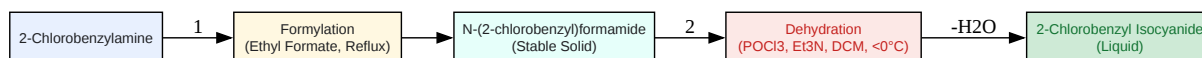

[Click to download full resolution via product page](#)

Figure 1: Two-step synthetic pathway for 2-chlorobenzyl isocyanide.

### Detailed Methodology (Step 2: Dehydration)

**Safety Warning:** Perform ALL operations in a well-ventilated fume hood. Double-glove.

- Preparation: Dissolve N-(2-chlorobenzyl)formamide (10 mmol) in anhydrous dichloromethane (DCM, 50 mL) and triethylamine (Et<sub>3</sub>N, 30 mmol).
- Cooling (Critical): Cool the solution to -5 °C to 0 °C using an ice/salt bath.
  - Why? Isocyanides are acid-sensitive and prone to polymerization. Low temperature controls the exotherm of the POCl<sub>3</sub> addition.
- Dehydration: Dropwise add phosphorus oxychloride (POCl<sub>3</sub>, 11 mmol) over 20 minutes. Maintain internal temperature below 5 °C.

- Reaction: Stir at 0 °C for 1 hour. Monitor by TLC (the formamide spot will disappear; a less polar isocyanide spot will appear).
- Quench: Pour the mixture into a stirred solution of saturated Na<sub>2</sub>CO<sub>3</sub> (aq) and ice.
  - Why? Basic quench neutralizes HCl and POCl<sub>3</sub> residues immediately, preventing acid-catalyzed hydrolysis of the isocyanide product.
- Workup: Separate the organic layer.[4][5] Wash with water (2x) and brine (1x). Dry over Na<sub>2</sub>SO<sub>4</sub>. [2]
- Purification: Flash chromatography on silica gel (eluent: Hexane/EtOAc 9:1) or vacuum distillation (if >5g scale).

## Reactivity & Applications in Drug Design[11]

The 2-chlorobenzyl moiety is a "privileged structure" in medicinal chemistry, often improving metabolic stability and lipophilicity compared to unsubstituted benzyl groups.

## The Ugi Four-Component Reaction (U-4CR)

2-Chlorobenzyl isocyanide reacts with an amine, an aldehyde, and a carboxylic acid to form a bis-amide backbone.

- Steric Influence: The ortho-chloro substituent creates steric bulk near the reacting isocyanide carbon. This can be leveraged to induce diastereoselectivity in the formation of the new chiral center during the addition of the nucleophile to the nitrilium ion intermediate.
- Mechanism: The reaction proceeds via the formation of an imine, protonation by the acid, nucleophilic attack by the isocyanide (rate-limiting), and subsequent Mumm rearrangement.

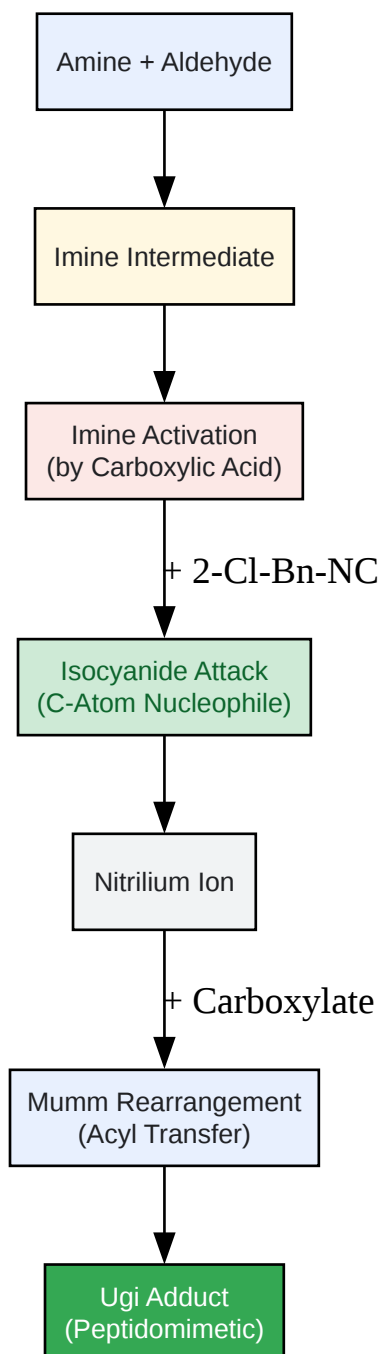

[Click to download full resolution via product page](#)

Figure 2: Mechanistic flow of the Ugi-4CR utilizing 2-chlorobenzyl isocyanide.

## Passerini Three-Component Reaction (P-3CR)

Reacts with an aldehyde and carboxylic acid to form

-acyloxycarboxamides. This is particularly useful for synthesizing depsipeptides.

## Safety & Odor Management (The "Trustworthiness" Pillar)

Isocyanides are notorious for their "Godzilla of Scent" profile.<sup>[6]</sup> The odor is not just unpleasant; it is persistent and can adhere to clothing and skin for days.

### Odor Quenching Protocol

Never dispose of isocyanide waste directly into the drain or general organic waste without quenching.

- The Chemistry: Acid-catalyzed hydrolysis converts the vile isocyanide back into the amine (fishy but manageable) and formic acid.
- The Solution: Prepare a "Quench Bath" consisting of 10% Sulfuric Acid in Methanol.
- Procedure:
  - Rinse all glassware (flasks, spatulas, syringes) with the Quench Bath immediately after use.
  - Soak contaminated septa or plasticware in the bath for 24 hours before disposal.
  - Wipe down the rotavap cold finger with a paper towel soaked in the Quench Bath.

### Toxicity<sup>[7]</sup><sup>[8]</sup><sup>[15]</sup>

- Acute Toxicity: Harmful by inhalation, ingestion, and skin contact.
- Target Organs: Central nervous system (similar to nitriles, though metabolic release of cyanide is slower/different).
- PPE: Standard lab coat, safety glasses, and nitrile gloves (latex is permeable to many organic solvents carrying the isocyanide).

## References

- Kitano, Y., et al. (2006).[3] "A Convenient Method for the Preparation of Benzyl Isocyanides." [7] Synthesis, 2006(3), 405-410.
- Ugi, I. (1962). "The  $\alpha$ -Addition of Immonium Ions and Anions to Isonitriles Accompanied by Secondary Reactions." Angewandte Chemie International Edition, 1(1), 8-21.
- Organic Syntheses. "Preparation of tert-Butyl Isocyanide" (General protocol adaptation). Org. [4] Synth. 1976, 55, 96.
- Avantor/Ambeed. "2-Chlorobenzyl isocyanide Product Specifications."

### Need Custom Synthesis?

BenchChem offers custom synthesis for rare earth carbides and specific isotopic labeling.

Email: [info@benchchem.com](mailto:info@benchchem.com) or [Request Quote Online](#).

## Sources

- [1. Preparation of Isocyanides - The Kubiak Lab Manual \[kubiak.ucsd.edu\]](#)
- [2. pdf.benchchem.com \[pdf.benchchem.com\]](#)
- [3. A Convenient Method for the Preparation of Benzyl Isocyanides \[organic-chemistry.org\]](#)
- [4. Organic Syntheses Procedure \[orgsyn.org\]](#)
- [5. Organic Syntheses Procedure \[orgsyn.org\]](#)
- [6. Novel noncovalent bond blocks repulsive odor of isocyanides, key reagents in organic synthesis - Institute of Chemistry, SPBU \[en-chem.spbu.ru\]](#)
- [7. apps.dtic.mil \[apps.dtic.mil\]](#)
- To cite this document: BenchChem. [Physicochemical Profile & Synthetic Utility of 2-Chlorobenzyl Isocyanide]. BenchChem, [2026]. [Online PDF]. Available at: [\[https://www.benchchem.com/product/b3416100/docs#physicochemical-profile-synthetic-utility-of-2-chlorobenzyl-isocyanide\]](https://www.benchchem.com/product/b3416100/docs#physicochemical-profile-synthetic-utility-of-2-chlorobenzyl-isocyanide)

---

### Disclaimer & Data Validity:

The information provided in this document is for Research Use Only (RUO) and is strictly not intended for diagnostic or therapeutic procedures. While BenchChem strives to provide accurate protocols, we make no warranties, express or implied, regarding the fitness of this product for every specific experimental setup.

**Technical Support:** The protocols provided are for reference purposes. Unsure if this reagent suits your experiment?

**Need Industrial/Bulk Grade?** [Request Custom Synthesis Quote](#)

## BenchChem

Our mission is to be the trusted global source of essential and advanced chemicals, empowering scientists and researchers to drive progress in science and industry.

### Contact

Address: 3281 E Guasti Rd  
Ontario, CA 91761, United States  
Phone: (601) 213-4426  
Email: [info@benchchem.com](mailto:info@benchchem.com)

[Contact our Ph.D. Support Team for a compatibility check](#)