

Cross-validation of HCH data between GC-ECD and GC-MS

Author: BenchChem Technical Support Team. **Date:** May 2026

Compound of Interest

Compound Name: *Hexachlorocyclohexane*

CAS No.: *6108-11-8*

Cat. No.: *B3416730*

[Get Quote](#)

Cross-Validation of HCH Data: GC-ECD vs. GC-MS

Executive Summary

In the rigorous landscape of pharmaceutical impurity profiling and environmental toxicology, the analysis of **Hexachlorocyclohexane** (HCH) isomers (

,

,

-Lindane,

) presents a classic analytical dilemma: the trade-off between sensitivity and specificity.

This guide serves as a technical blueprint for cross-validating data between Gas Chromatography-Electron Capture Detection (GC-ECD) and Gas Chromatography-Mass Spectrometry (GC-MS). While GC-ECD offers superior sensitivity for halogenated compounds (often 10-100x lower detection limits), it lacks structural confirmation capabilities, leading to

potential false positives.[1] Conversely, GC-MS provides definitive structural identification but historically struggles to match ECD's sensitivity for trace-level organochlorines.[1]

This document outlines a self-validating workflow to integrate these orthogonal techniques, ensuring regulatory compliance (USP <561>, EPA 8081B/8270D) and data integrity.

Technical Foundation: The Physics of Detection

To validate data across platforms, one must first understand the distinct physical mechanisms generating that data.

GC-ECD: The Electrophilic Trap

The Electron Capture Detector (ECD) is a selective, non-destructive detector. It utilizes a radioactive source (typically

Ni) to generate a standing current of electrons.[1] Electronegative analytes—specifically the six chlorine atoms on the HCH ring—capture these electrons, causing a measurable decrease in current.

- Advantage: Extreme sensitivity to halogens (Femtogram level).[1][2]
- Limitation: Retention-time dependent only. Phthalates or PCBs can co-elute and mimic HCH signals.[1]

GC-MS (SIM Mode): The Mass Filter

Mass Spectrometry (MS) using Electron Ionization (EI) fragments the molecule. By utilizing Selected Ion Monitoring (SIM), we filter out matrix noise and focus only on characteristic HCH fragments (e.g., m/z 181, 219).[1]

- Advantage: Structural fingerprinting.[1] Distinguishes HCH from co-eluting non-isobaric interferences.[1]
- Limitation: Lower signal-to-noise ratio compared to ECD at ultra-trace levels.[1]

Visualizing the Detection Logic

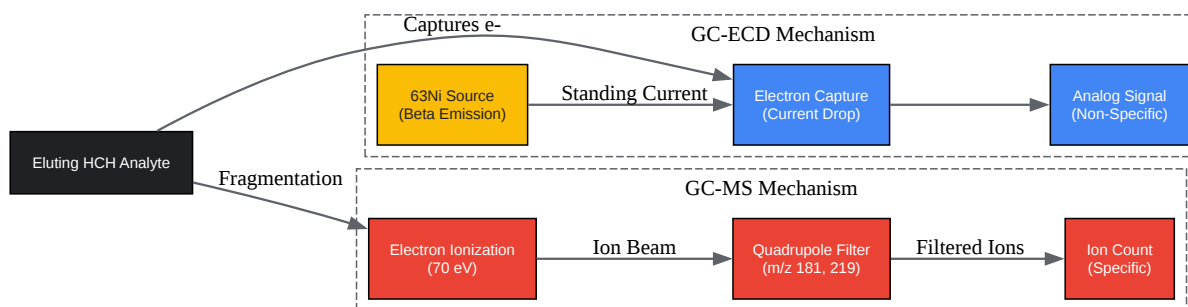

[Click to download full resolution via product page](#)

Figure 1: Comparative signal generation pathways. ECD relies on current suppression (physical property), while MS relies on mass-to-charge filtration (chemical structure).[1]

Experimental Protocol

To ensure data comparability, sample preparation must be unified.[1] Divergent extraction methods introduce variables that invalidate the cross-comparison.

Unified Sample Preparation (Automated Soxhlet or SPE) [1]

- Matrix: Pharmaceutical excipients or water.[1]
- Extraction: Solid Phase Extraction (SPE) using C18 or Florisil cartridges is recommended for high throughput and cleanliness.[1]
- Solvent Exchange: Critical step.[1]
 - Extract in Acetone/Hexane.[1]
 - Split the sample:

- Aliquot A (for ECD): Exchange to Hexane (ECD is sensitive to chlorinated solvents like DCM).[1]
- Aliquot B (for MS): Hexane or Isooctane is acceptable.[1]

Instrument Parameters

Parameter	GC-ECD (Screening)	GC-MS (Confirmation)
Instrument	Agilent 7890B / 8890	Agilent 7890B / 5977B MSD
Column	DB-CLP1 or TG-5SilMS (30m x 0.25mm x 0.25µm)	Same phase recommended for RT matching
Carrier Gas	Nitrogen or Helium (High purity)	Helium (Required for MS)
Inlet	Splitless, 250°C	Splitless, 250°C
Oven Ramp	80°C (1 min) -> 30°C/min -> 170°C -> 5°C/min -> 240°C	Same profile to align Retention Times (RT)
Detector	µECD @ 300°C	MSD Source @ 230°C, Quad @ 150°C
Acquisition	N/A	SIM Mode: Ions 181, 183, 217, 219

Cross-Validation Logic: The "Self-Validating" Workflow[1]

The core of this guide is the decision logic. You cannot simply average the results of ECD and MS. The ECD serves as the quantitative anchor for sensitivity, while the MS serves as the qualitative gatekeeper.

The Validation Algorithm

- Run ECD: Calculate concentration based on external standard calibration.
- Check Threshold: If ECD signal < MS LOQ, report ECD value (with caveat).

- Run MS (if > LOQ): Confirm presence via ion ratio (Target/Qualifier within $\pm 20\%$).
- Calculate RPD: If both are quantifiable, calculate Relative Percent Difference.

[1]

- Acceptance: RPD < 30% is generally acceptable for trace residues.[1]

Decision Tree Diagram

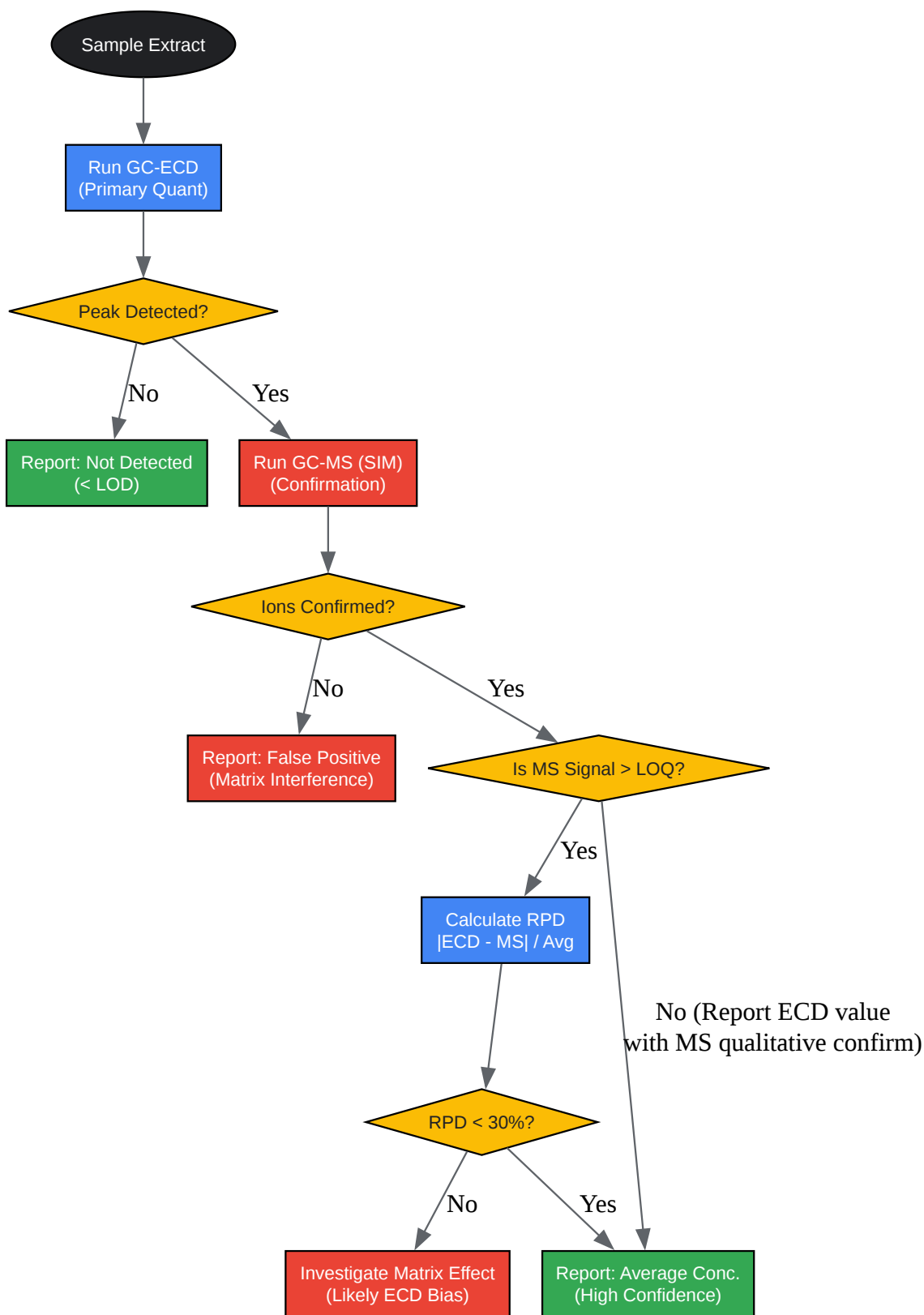

[Click to download full resolution via product page](#)

Figure 2: Logic flow for validating HCH presence. This system prevents reporting false positives common in ECD analysis.

Performance Comparison Data

The following data represents typical performance metrics observed in a validation study of HCH in water/excipient matrices.

Sensitivity (LOD/LOQ)

Note the superior sensitivity of ECD. This is why ECD remains the screening method of choice.

Analyte	GC-ECD LOD (pg/mL)	GC-ECD LOQ (pg/mL)	GC-MS (SIM) LOD (pg/mL)	GC-MS (SIM) LOQ (pg/mL)
-HCH	0.5	1.5	5.0	15.0
-HCH	1.0	3.0	8.0	24.0
-HCH (Lindane)	0.5	1.5	4.5	13.5
-HCH	0.8	2.4	6.0	18.0

Linearity and Recovery

Both methods demonstrate excellent linearity, but MS often shows slightly lower recovery at the lowest levels due to adsorption in the ion source or lower signal-to-noise ratios.^[1]

Parameter	GC-ECD Performance	GC-MS (SIM) Performance
Linearity ()	> 0.999 (0.5 - 100 ppb)	> 0.998 (5.0 - 200 ppb)
Recovery (Spike @ 10 ppb)	95% - 105%	90% - 102%
Precision (%RSD)	< 3.0%	< 5.0%

Troubleshooting & Optimization

The "ECD High / MS Low" Discrepancy

This is the most common cross-validation failure.

- Cause: Co-eluting electronegative compounds (e.g., phthalates from plasticware, chlorinated solvents).[1]
- Solution: Rely on the MS data if the ion ratios are correct. The MS is "blind" to the interference that the ECD sees. If MS is < LOQ but ECD is high, treat as a False Positive or Suspect result.[1]

The "MS High / ECD Low" Discrepancy

Rare, but possible.

- Cause: Quenching of the ECD signal by high concentrations of hydrocarbons, or saturation of the detector.
- Solution: Dilute the sample 1:10 and re-inject on ECD.

Column Bleed[1]

- Impact: ECD is highly sensitive to column bleed (stationary phase loss), which causes a rising baseline.[1]
- Mitigation: Use "MS-Grade" or "Low-Bleed" columns (e.g., DB-5ms, TG-5SilMS) for both detectors.[1] Never use a standard grade column for trace HCH analysis on ECD.[1]

References

- U.S. Environmental Protection Agency. (2007).[1] Method 8081B: Organochlorine Pesticides by Gas Chromatography.[1][3][4] SW-846.[1][3] [\[Link\]](#)[1]
- U.S. Environmental Protection Agency. (2014).[1] Method 8270D: Semivolatile Organic Compounds by Gas Chromatography/Mass Spectrometry (GC/MS).[1] SW-846.[1][3] [\[Link\]](#) [1]

- Agilent Technologies. (2021).[1] Organochlorine Pesticides Analysis in Water by GC/ECD: Optimization of EPA Method 8081B. [[Link](#)][1]

Need Custom Synthesis?

BenchChem offers custom synthesis for rare earth carbides and specific isotopic labeling.

Email: info@benchchem.com or [Request Quote Online](#).

Sources

- 1. semspub.epa.gov [semspub.epa.gov]
- 2. Brain metabolites of lindane and related isomers: identification by negative ion mass spectrometry - PubMed [pubmed.ncbi.nlm.nih.gov]
- 3. [agilent.com](https://www.agilent.com) [[agilent.com](https://www.agilent.com)]
- 4. documents.thermofisher.com [documents.thermofisher.com]
- To cite this document: BenchChem. [Cross-validation of HCH data between GC-ECD and GC-MS]. BenchChem, [2026]. [Online PDF]. Available at: [<https://www.benchchem.com/product/b3416730/docs#cross-validation-of-hch-data-between-gc-ecd-and-gc-ms>]

Disclaimer & Data Validity:

The information provided in this document is for Research Use Only (RUO) and is strictly not intended for diagnostic or therapeutic procedures. While BenchChem strives to provide accurate protocols, we make no warranties, express or implied, regarding the fitness of this product for every specific experimental setup.

Technical Support: The protocols provided are for reference purposes. Unsure if this reagent suits your experiment?

Need Industrial/Bulk Grade? [Request Custom Synthesis Quote](#)

BenchChem

Our mission is to be the trusted global source of essential and advanced chemicals, empowering scientists and researchers to drive progress in science and industry.

Contact

Address: 3281 E Guasti Rd

Ontario, CA 91761, United States

Phone: (601) 213-4426

Email: info@benchchem.com

[Contact our Ph.D. Support Team for a compatibility check](#)