

# Application Note: Quantitative Analysis of Catechins in Human Plasma by UPLC-MS/MS

**Author:** BenchChem Technical Support Team. **Date:** April 2026

## Compound of Interest

Compound Name:	Catechin
CAS No.:	100786-01-4
Cat. No.:	B3416984

[Get Quote](#)

## Abstract

This application note details a robust and sensitive Ultra-Performance Liquid Chromatography-Tandem Mass Spectrometry (UPLC-MS/MS) method for the simultaneous quantification of four major green tea **catechins**—epigallocatechin-3-gallate (EGCG), epicatechin-3-gallate (ECG), epigallocatechin (EGC), and epicatechin (EC)—in human plasma.<sup>[1][2][3][4][5]</sup> The described protocol provides a reliable and reproducible workflow for pharmacokinetic studies and clinical research involving these beneficial polyphenolic compounds. The method demonstrates excellent linearity, precision, accuracy, and sensitivity, making it suitable for demanding research and drug development applications.

## Introduction

**Catechins**, a class of flavonoids abundant in green tea, have garnered significant attention for their potential health benefits, including antioxidant, anti-inflammatory, and chemopreventive properties. To understand their bioavailability, metabolism, and pharmacokinetic profiles, a highly sensitive and specific analytical method for their quantification in biological matrices is essential. UPLC-MS/MS offers superior resolution, speed, and sensitivity compared to

conventional HPLC methods, making it the ideal platform for analyzing these compounds in complex biological samples like human plasma. This document provides a detailed protocol for the quantitative analysis of EGCG, ECG, EGC, and EC in human plasma using UPLC-MS/MS.

## Experimental Workflow

The overall experimental workflow for the quantitative analysis of **catechins** in human plasma is depicted below.



[Click to download full resolution via product page](#)

Caption: Experimental workflow for **catechin** analysis in human plasma.

## Detailed Experimental Protocols

### Sample Preparation

This protocol is optimized for the extraction of four major **catechins** from human plasma.

Materials:

- Human plasma samples
- Ethyl gallate (Internal Standard, I.S.)
- Acetonitrile (ACN), HPLC grade
- Water, HPLC grade
- Formic acid
- Microcentrifuge tubes (1.5 mL)

- Pipettes and tips
- Centrifuge
- Nitrogen evaporator
- Vortex mixer

#### Procedure:

- Pipette 100  $\mu$ L of human plasma into a 1.5 mL microcentrifuge tube.
- Add 10  $\mu$ L of the internal standard working solution (Ethyl Gallate).
- Add 300  $\mu$ L of acetonitrile to precipitate plasma proteins.
- Vortex the mixture for 1 minute.
- Centrifuge the tubes at 13,000 rpm for 10 minutes at 4°C.
- Carefully transfer 80% of the clear supernatant to a new microcentrifuge tube.
- Evaporate the supernatant to dryness under a gentle stream of nitrogen at 40°C.
- Reconstitute the dried residue in 100  $\mu$ L of the mobile phase (Water:Acetonitrile, 85:15, v/v with 0.1% formic acid).
- Vortex for 30 seconds to ensure complete dissolution.
- Transfer the reconstituted sample to an autosampler vial for UPLC-MS/MS analysis.

## UPLC-MS/MS Conditions

#### Instrumentation:

- Waters ACQUITY UPLC System
- Waters Xevo TQ-S Mass Spectrometer

- Atlantis T3 Column (4.6 mm × 50 mm, 3 μm)

## UPLC Parameters:

Parameter	Value
Column	Atlantis T3 (4.6 mm × 50 mm, 3 μm)
Mobile Phase A	Water with 0.1% Formic Acid
Mobile Phase B	Acetonitrile with 0.1% Formic Acid
Flow Rate	0.4 mL/min
Injection Volume	5 μL
Column Temperature	40°C
Run Time	10 minutes

## Gradient Elution Program:

Time (min)	% Mobile Phase A	% Mobile Phase B
0.0	85	15
2.0	85	15
5.0	20	80
7.0	20	80
7.1	85	15
10.0	85	15

## Mass Spectrometry Parameters:

The mass spectrometer was operated in Multiple Reaction Monitoring (MRM) mode with negative electrospray ionization.

Analyte	Precursor Ion (m/z)	Product Ion (m/z)
EGCG	457.15	168.98
ECG	443.10	123.00
EGC	307.20	151.00
EC	291.20	139.00
Ethyl Gallate (I.S.)	199.01	127.03

## Method Validation and Performance

The UPLC-MS/MS method was validated for linearity, sensitivity, accuracy, precision, recovery, and matrix effect.

### Linearity and Lower Limit of Quantification (LLOQ)

The calibration curves were linear over the specified concentration ranges. The LLOQ was determined as the lowest concentration on the calibration curve with a signal-to-noise ratio greater than 5.

Analyte	Calibration Range (ng/mL)	LLOQ (ng/mL)
EGCG	1 - 500	1.0
ECG	1 - 500	1.0
EGC	1 - 500	1.0
EC	0.1 - 50	0.1

## Accuracy and Precision

Intra-day and inter-day accuracy and precision were evaluated at low, medium, and high quality control (QC) concentrations.

### Intra-day Accuracy and Precision

Analyte	Concentration (ng/mL)	Accuracy (%)	Precision (CV, %)
EGCG	3	108.2	8.7
30	97.4	4.3	
300	98.6	2.1	
ECG	3	105.3	7.5
30	95.8	3.9	
300	99.1	1.8	
EGC	3	111.3	9.2
30	96.5	5.1	
300	98.9	2.5	
EC	0.3	107.8	8.1
3	98.2	4.7	
30	99.5	2.3	

## Inter-day Accuracy and Precision

Analyte	Concentration (ng/mL)	Accuracy (%)	Precision (CV, %)
EGCG	3	103.5	6.4
30	95.1	3.8	
300	97.2	1.9	
ECG	3	101.7	5.9
30	93.8	3.2	
300	98.4	1.5	
EGC	3	106.9	7.8
30	94.7	4.5	
300	98.1	2.2	
EC	0.3	104.6	7.3
3	96.9	4.1	
30	98.7	2.0	

## Recovery and Matrix Effect

The extraction recovery and matrix effect were assessed to ensure the reliability of the sample preparation method.

Analyte	Concentration (ng/mL)	Recovery (%)	Matrix Effect (%)
EGCG	3	92.5	95.8
300	95.1	97.2	
ECG	3	90.8	94.3
300	93.7	96.5	
EGC	3	88.9	93.1
300	91.5	95.4	
EC	0.3	85.7	91.8
30	88.2	94.1	

## Conclusion

The UPLC-MS/MS method described in this application note provides a rapid, sensitive, and reliable approach for the simultaneous quantification of four major **catechins** in human plasma. The detailed protocols and performance data demonstrate the suitability of this method for pharmacokinetic and clinical studies aimed at elucidating the biological activities of green tea **catechins**.

## Signaling Pathway Diagram

While this application note focuses on the analytical methodology, the biological effects of **catechins** are often linked to their interaction with various cellular signaling pathways. The diagram below illustrates a simplified, hypothetical signaling pathway that could be influenced by **catechins**.

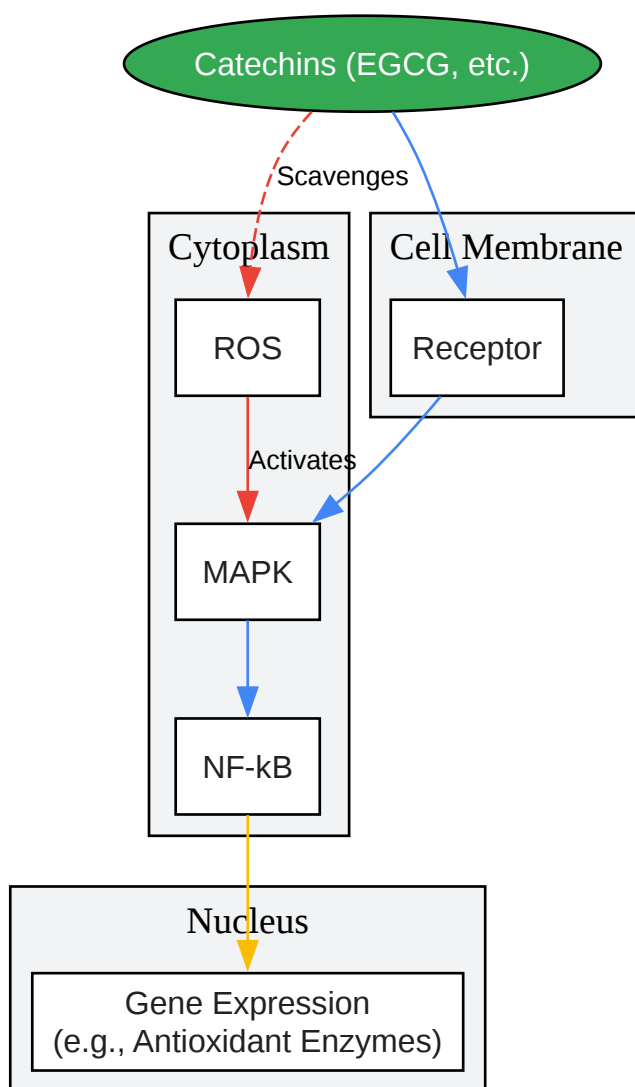

[Click to download full resolution via product page](#)

Caption: Hypothetical signaling pathway influenced by **catechins**.

### Need Custom Synthesis?

BenchChem offers custom synthesis for rare earth carbides and specific isotopic labeling.

Email: [info@benchchem.com](mailto:info@benchchem.com) or [Request Quote Online](#).

## References

- 1. Quantitative Analysis of Four Catechins from Green Tea Extract in Human Plasma Using Ultra-Performance Liquid Chromatography-Tandem Mass Spectrometry for Pharmacokinetic Studies - PMC [[pmc.ncbi.nlm.nih.gov](https://pubmed.ncbi.nlm.nih.gov)]
- 2. Quantitative Analysis of Four Catechins from Green Tea Extract in Human Plasma Using Ultra-Performance Liquid Chromatography-Tandem Mass Spectrometry for Pharmacokinetic Studies - PubMed [[pubmed.ncbi.nlm.nih.gov](https://pubmed.ncbi.nlm.nih.gov)]
- 3. [PDF] Quantitative Analysis of Four Catechins from Green Tea Extract in Human Plasma Using Ultra-Performance Liquid Chromatography-Tandem Mass Spectrometry for Pharmacokinetic Studies | Semantic Scholar [[semanticscholar.org](https://www.semanticscholar.org)]
- 4. [researchgate.net](https://www.researchgate.net) [[researchgate.net](https://www.researchgate.net)]
- 5. [논문]Quantitative Analysis of Four Catechins from Green Tea Extract in Human Plasma Using Ultra-Performance Liquid Chromatography-Tandem Mass Spectrometry for Pharmacokinetic Studies [[scienceon.kisti.re.kr](https://scienceon.kisti.re.kr)]
- To cite this document: BenchChem. [Application Note: Quantitative Analysis of Catechins in Human Plasma by UPLC-MS/MS]. BenchChem, [2026]. [Online PDF]. Available at: [<https://www.benchchem.com/product/b3416984/docs#application-note-quantitative-analysis-of-catechins-in-human-plasma-by-uplc-ms-ms>]

---

#### Disclaimer & Data Validity:

The information provided in this document is for Research Use Only (RUO) and is strictly not intended for diagnostic or therapeutic procedures. While BenchChem strives to provide accurate protocols, we make no warranties, express or implied, regarding the fitness of this product for every specific experimental setup.

**Technical Support:** The protocols provided are for reference purposes. Unsure if this reagent suits your experiment?

**Need Industrial/Bulk Grade?** [Request Custom Synthesis Quote](#)

# BenchChem

Our mission is to be the trusted global source of essential and advanced chemicals, empowering scientists and researchers to drive progress in science and industry.

## Contact

Address: 3281 E Guasti Rd

Ontario, CA 91761, United States

Phone: (601) 213-4426

Email: [info@benchchem.com](mailto:info@benchchem.com)

[Contact our Ph.D. Support Team for a compatibility check](#)