

Addressing poor recovery of NM-2201 during sample extraction

Author: BenchChem Technical Support Team. **Date:** April 2026

Compound of Interest

Compound Name:	NM-2201
CAS No.:	2042201-16-9
Cat. No.:	B3415420

[Get Quote](#)

Technical Support Center: NM-2201 Sample Extraction

This technical support center provides troubleshooting guides and frequently asked questions (FAQs) to address the common challenge of poor recovery of the synthetic cannabinoid **NM-2201** during sample extraction. This resource is intended for researchers, scientists, and drug development professionals.

Frequently Asked Questions (FAQs)

Q1: What are the key chemical properties of **NM-2201** that affect its extraction?

NM-2201 (Naphthalen-1-yl 1-(5-fluoropentyl)-1H-indole-3-carboxylate) is a highly lipophilic synthetic cannabinoid. Its chemical structure includes an ester linkage, which makes it susceptible to hydrolysis. Additionally, **NM-2201** is sensitive to heat and light, which can lead to degradation if not handled properly during extraction and storage. Its high lipophilicity means it has low solubility in aqueous solutions, which can impact its recovery from biological matrices.

Q2: I am observing very low or no recovery of the parent **NM-2201** in urine samples. Is this normal?

Yes, this is a common finding. **NM-2201** is extensively metabolized in the body, primarily through ester hydrolysis.[1][2] As a result, the parent compound is often not detected in urine specimens. The major metabolite, M13 (5-fluoro PB-22 3-carboxyindole), is the primary target for confirming **NM-2201** intake in urine analysis.[1] Therefore, analytical methods should be optimized for the detection of its metabolites.

Q3: Which sample extraction techniques are most suitable for **NM-2201**?

The choice of extraction technique depends on the sample matrix.

- For urine: Supported Liquid Extraction (SLE) and Solid-Phase Extraction (SPE) are commonly used.
- For blood/plasma: Protein precipitation followed by Liquid-Liquid Extraction (LLE) or SPE is often employed.
- For hair: Methanol-based extraction is a common method.

Q4: How critical is pH control during the extraction of **NM-2201**?

While **NM-2201** itself is a neutral compound, the pH of the sample can influence the extraction of its metabolites, particularly the carboxylated metabolite (M13). Acidifying the sample can help to neutralize the charge on the carboxylic acid group, making it less water-soluble and more amenable to extraction with organic solvents.

Q5: What are the best practices for storing samples containing **NM-2201**?

Due to its instability, samples should be stored at low temperatures (-20°C or below) and protected from light to minimize degradation.[3] Repeated freeze-thaw cycles should be avoided. Using silanized glass vials for storage can help to prevent the adsorption of the lipophilic **NM-2201** to the container surface.

Troubleshooting Guide: Poor Recovery of **NM-2201**

This guide provides a systematic approach to troubleshooting poor recovery of **NM-2201** and its metabolites during sample extraction.

Problem	Potential Cause	Troubleshooting Steps & Solutions
Low/No Analyte Detected	Analyte Degradation	<ul style="list-style-type: none"> • Minimize Exposure to Heat and Light: Perform extraction steps in a cool environment and use amber vials or foil-wrapped tubes. • Check for Hydrolysis: The ester linkage in NM-2201 is prone to hydrolysis. Ensure that the sample pH and temperature are controlled during processing. For urine analysis, target the more stable metabolites.
Inefficient Extraction from Matrix	<ul style="list-style-type: none"> • Optimize Solvent Choice (LLE): For the highly lipophilic NM-2201, a non-polar solvent like hexane in combination with a more polar solvent like ethyl acetate may improve recovery. • Select Appropriate Sorbent (SPE): A reversed-phase sorbent (e.g., C8 or C18) is generally suitable for NM-2201. Ensure proper conditioning of the SPE cartridge to activate the sorbent. • Enhance Elution Strength (SPE): If the analyte is strongly retained, increase the percentage of organic solvent in the elution buffer or try a different elution solvent. 	
Matrix Effects	<ul style="list-style-type: none"> • Improve Sample Cleanup: Incorporate additional washing 	

steps in your SPE protocol or consider a different extraction technique (e.g., SLE) that provides a cleaner extract. • Use a Matrix-Matched Calibrator: Prepare calibration standards in the same biological matrix as the samples to compensate for matrix-induced signal suppression or enhancement. • Employ an Internal Standard: A stable isotope-labeled internal standard for NM-2201 or its main metabolite can help to correct for recovery losses and matrix effects.

Inconsistent Recovery

Poor Method Reproducibility

- Ensure Complete Solvent Evaporation: If a solvent evaporation step is used, ensure it is carried out to completion without excessive heat, which could degrade the analyte. • Standardize Vortexing/Mixing Times: Ensure consistent mixing times and intensity for all samples to maintain uniformity. • Check for Emulsion Formation (LLE): If emulsions form, they can trap the analyte. Use gentle mixing or centrifugation to break the emulsion.

Adsorption to Surfaces

- Use Silanized Glassware: The lipophilic nature of NM-2201 can cause it to adsorb to glass and plastic surfaces.

Using silanized glassware can minimize this issue.

Data on Extraction Recovery

Quantitative data on the extraction recovery of **NM-2201** is not widely available in the literature. However, studies on similar synthetic cannabinoids can provide an expected range for recovery.

Extraction Method	Matrix	Analyte(s)	Reported Recovery Range (%)	Reference
Solid-Phase Extraction (SPE)	Urine	61 Synthetic Cannabinoid Metabolites	43 - 97	[4]
Methanol Extraction	Hair	29 Synthetic Cannabinoids and Metabolites	36.1 - 93.3	[5]
Liquid-Liquid Extraction (LLE)	Urine	AM-2201 Metabolites	Not specified, but method validated	[6]
Supported Liquid Extraction (SLE)	Urine	NM-2201 and its metabolites	Not specified, but method used for analysis	[2]

Note: The recovery rates can be highly dependent on the specific analyte, matrix, and the exact protocol used. It is crucial to validate the extraction method in your own laboratory to determine the actual recovery.

Experimental Protocols

Supported Liquid Extraction (SLE) for NM-2201 Metabolites in Urine

This protocol is adapted from methodologies used for the analysis of synthetic cannabinoids in urine.[2]

- **Sample Pre-treatment:** To 1 mL of urine, add an internal standard. If targeting glucuronidated metabolites, perform enzymatic hydrolysis with β -glucuronidase.
- **Sample Loading:** Load the pre-treated sample onto an Isolute® SLE+ 1 mL cartridge. Apply a gentle positive pressure or vacuum to allow the sample to be absorbed into the sorbent.
- **Elution:** Elute the analytes from the cartridge by passing 2 x 1.5 mL of ethyl acetate through the cartridge.
- **Solvent Evaporation:** Evaporate the eluate to dryness under a gentle stream of nitrogen at a temperature not exceeding 40°C.
- **Reconstitution:** Reconstitute the dried extract in a suitable solvent (e.g., 100 μ L of mobile phase) for LC-MS/MS analysis.

Liquid-Liquid Extraction (LLE) for NM-2201 in Blood/Plasma

- **Protein Precipitation:** To 1 mL of blood or plasma, add 2 mL of cold acetonitrile containing an internal standard. Vortex vigorously to precipitate proteins.
- **Centrifugation:** Centrifuge the sample at high speed (e.g., 10,000 x g) for 10 minutes to pellet the precipitated proteins.
- **Supernatant Transfer:** Carefully transfer the supernatant to a clean tube.
- **Extraction:** Add 3 mL of a non-polar solvent (e.g., hexane or a hexane/ethyl acetate mixture). Vortex for 1-2 minutes.
- **Phase Separation:** Centrifuge at a lower speed (e.g., 3,000 x g) for 5 minutes to separate the aqueous and organic layers.
- **Collection:** Transfer the organic layer (top layer) to a new tube.

- Solvent Evaporation and Reconstitution: Evaporate the organic solvent and reconstitute the extract as described in the SLE protocol.

Visualizations

Experimental Workflow for NM-2201 Extraction from Urine using SLE

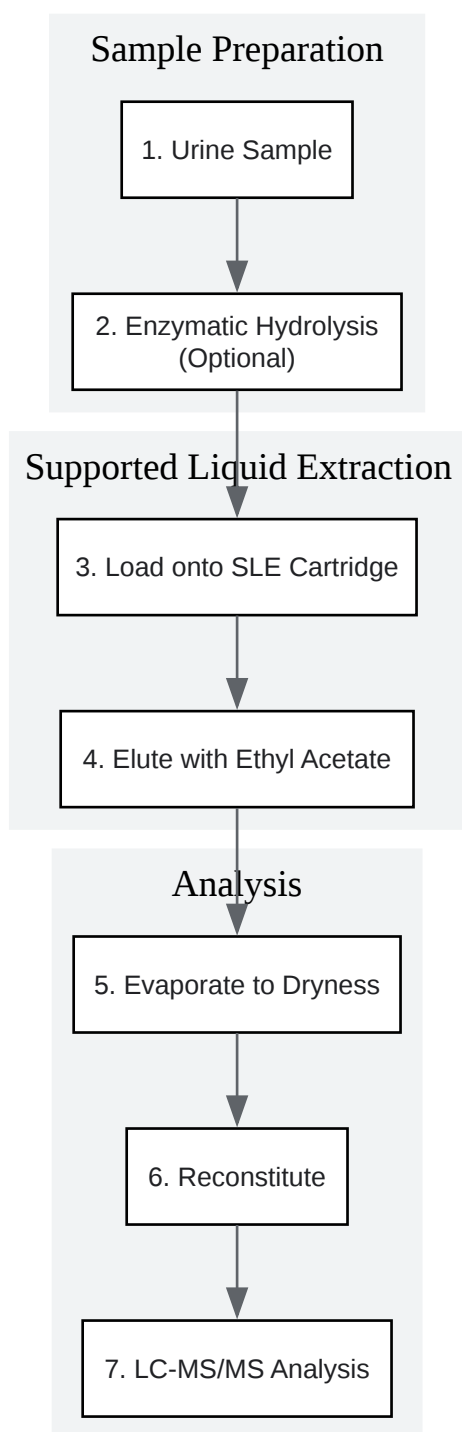

[Click to download full resolution via product page](#)

Caption: Workflow for Supported Liquid Extraction (SLE) of **NM-2201** from urine.

Troubleshooting Logic for Low NM-2201 Recovery

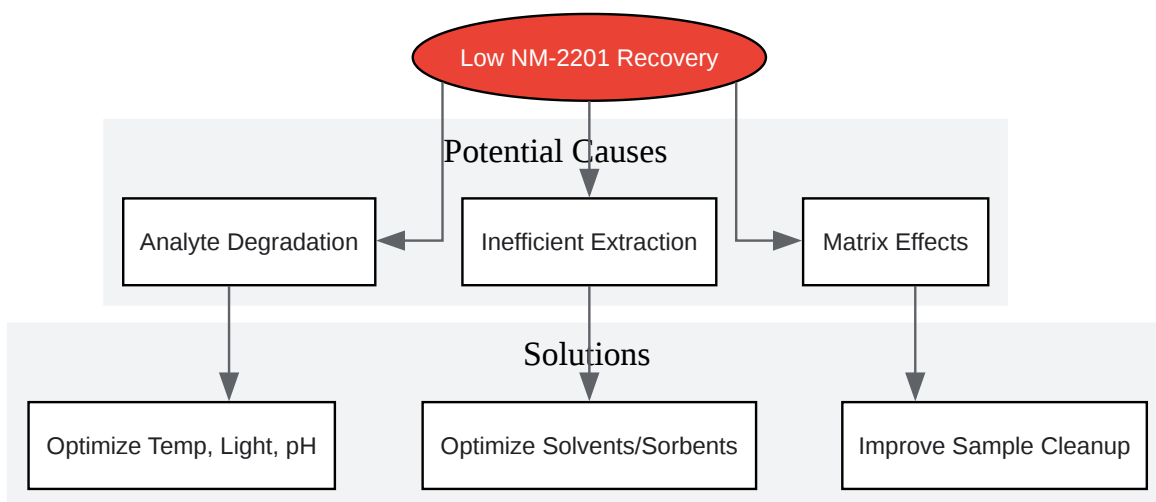

[Click to download full resolution via product page](#)

Caption: A logical approach to troubleshooting poor **NM-2201** recovery.

NM-2201 Signaling Pathway at the CB1 Receptor

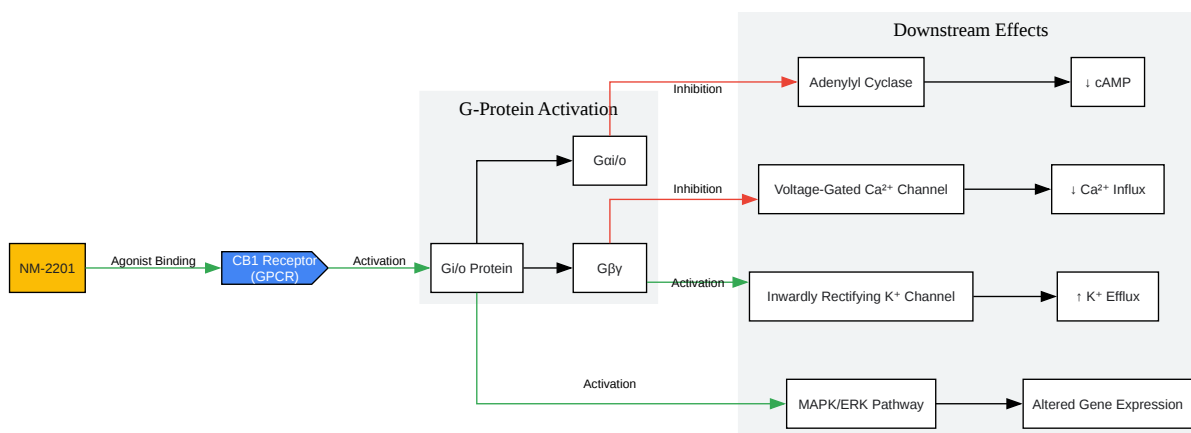

[Click to download full resolution via product page](#)

Caption: Simplified signaling pathway of **NM-2201** at the CB1 receptor.

Need Custom Synthesis?

BenchChem offers custom synthesis for rare earth carbides and specific isotopic labeling.

Email: info@benchchem.com or [Request Quote Online](#).

References

- [1. researchgate.net \[researchgate.net\]](#)
- [2. In vitro and in vivo human metabolism of a new synthetic cannabinoid NM-2201 \(CBL-2201\) - PMC \[pmc.ncbi.nlm.nih.gov\]](#)
- [3. Innovative Solid-Phase Extraction Strategies for Improving the Advanced Chromatographic Determination of Drugs in Challenging Biological Samples - PMC \[pmc.ncbi.nlm.nih.gov\]](#)
- [4. Solid-phase extraction-liquid chromatography-tandem mass spectrometry method for the qualitative analysis of 61 synthetic cannabinoid metabolites in urine - PubMed \[pubmed.ncbi.nlm.nih.gov\]](#)
- [5. Application of a UPLC-MS/MS method for quantitative analysis of 29 synthetic cannabinoids and their metabolites, such as ADB-BUTINACA and MDMB-4en-PINACA in human hair in real cases - PubMed \[pubmed.ncbi.nlm.nih.gov\]](#)
- [6. researchgate.net \[researchgate.net\]](#)
- To cite this document: BenchChem. [Addressing poor recovery of NM-2201 during sample extraction]. BenchChem, [2026]. [Online PDF]. Available at: [\[https://www.benchchem.com/product/b3415420/docs#addressing-poor-recovery-of-nm-2201-during-sample-extraction\]](https://www.benchchem.com/product/b3415420/docs#addressing-poor-recovery-of-nm-2201-during-sample-extraction)

Disclaimer & Data Validity:

The information provided in this document is for Research Use Only (RUO) and is strictly not intended for diagnostic or therapeutic procedures. While BenchChem strives to provide accurate protocols, we make no warranties, express or implied, regarding the fitness of this product for every specific experimental setup.

Technical Support: The protocols provided are for reference purposes. Unsure if this reagent suits your experiment?

Need Industrial/Bulk Grade? [Request Custom Synthesis Quote](#)

BenchChem

Our mission is to be the trusted global source of essential and advanced chemicals, empowering scientists and researchers to drive progress in science and industry.

Contact

Address: 3281 E Guasti Rd
Ontario, CA 91761, United States
Phone: (601) 213-4426
Email: info@benchchem.com

[Contact our Ph.D. Support Team for a compatibility check](#)