

# Preventing polymerization of spirocyclic amines during workup

**Author:** BenchChem Technical Support Team. **Date:** April 2026

## Compound of Interest

Compound Name: *1-Oxa-6-azaspiro[3.5]nonane oxalate*  
CAS No.: *1923051-63-1*  
Cat. No.: *B3393127*

[Get Quote](#)

## Technical Support Center: Spirocyclic Amine Handling

### Topic: Preventing Polymerization & Degradation During Workup

Ticket ID: SPIRO-STABILITY-001 Assigned Specialist: Senior Application Scientist, Process Chemistry Division

### Core Directive: The "Hidden" Reactivity

Welcome to the technical support center. You are likely here because your spirocyclic amine (e.g., 2-azaspiro[3.3]heptane, 2-azaspiro[3.4]octane) has behaved unexpectedly—turning into an insoluble gel, disappearing during evaporation, or decomposing into a brown tar.

The Root Cause: Spirocyclic amines are not just "amines"; they are high-strain energy scaffolds. The central spiro-carbon forces the rings (often 4-membered azetidines) into rigid

geometries with significant ring strain (~26 kcal/mol for azetidine).

In the free base form, the amine nitrogen is nucleophilic. If activated by trace acid, heat, or concentration, it attacks the strained ring of a neighboring molecule, triggering Cationic Ring-Opening Polymerization (CROP). This is an autocatalytic "suicide" mechanism.

## Mechanism of Failure

The following diagram illustrates the specific failure mode where a free base triggers a chain-growth polymerization event.

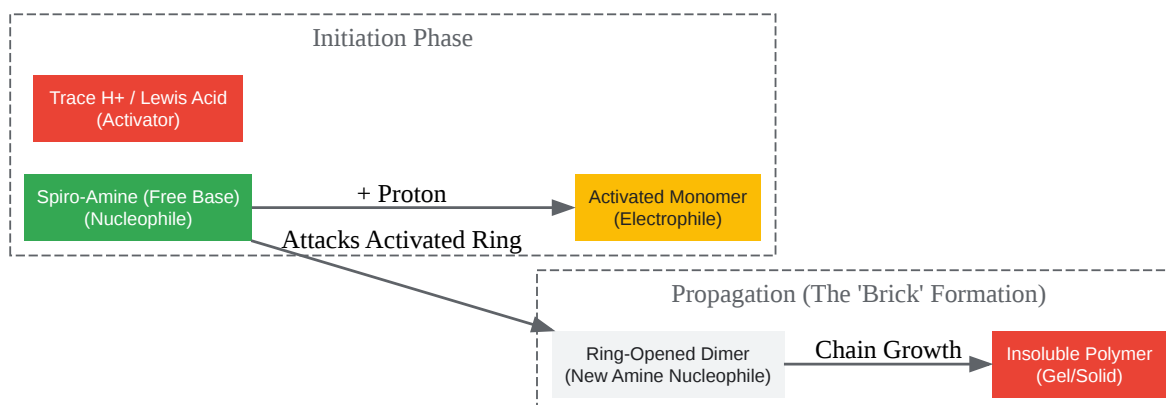

[Click to download full resolution via product page](#)

Figure 1: Cationic Ring-Opening Polymerization (CROP) pathway.[1] The strained ring acts as a loaded spring; once protonated, it becomes an electrophile susceptible to attack by the free base.

## Troubleshooting Guide (Symptom-Based)

### Case A: "My oil turned into a solid/gel on the rotavap."

Diagnosis: Concentration-dependent polymerization. Explanation: As you remove solvent, the concentration of amine increases. The heat from the water bath provides the activation energy for the nucleophilic attack on the strained ring. Corrective Action:

- Never concentrate to dryness as a free base.
- Stop evaporation when ~10-20% solvent remains.
- Immediate Salt Formation: Dilute the residue with Et<sub>2</sub>O or IPA and add acid (HCl in dioxane or Oxalic acid) immediately to lock the nitrogen lone pair.

## Case B: "The product disappeared after aqueous extraction."

Diagnosis: High water solubility (Low LogD). Explanation: Spirocyclic amines are compact and polar. The "hydrophobic masking" effect of the carbon scaffold is lower than linear alkyl chains. They partition into the aqueous phase, especially at neutral/acidic pH. Corrective Action:

- Salting Out: Saturate the aqueous phase with K<sub>2</sub>CO<sub>3</sub> (Potassium Carbonate), not NaCl.[2] K<sub>2</sub>CO<sub>3</sub> provides higher ionic strength and ensures a basic pH (pKa ~10) to keep the amine deprotonated.
- Solvent Switch: Use DCM:IPA (3:1) or CHCl<sub>3</sub> for extraction instead of pure EtOAc or Ether.

## Case C: "The compound turned brown/black overnight."

Diagnosis: Oxidative Degradation.[3][4][5] Explanation: Secondary amines in strained rings are prone to oxidation, forming imines or enamines which then couple or polymerize. Corrective Action:

- Argon Purge: Store all solutions under inert atmosphere.
- Avoid Chlorinated Solvents: Traces of HCl in DCM can catalyze decomposition.
- Cold Storage: Store as a salt at -20°C.

## Standard Operating Procedures (SOPs)

### Protocol 1: The "Safe-Salt" Isolation (Recommended)

Use this protocol to isolate the amine as a stable solid, bypassing the unstable free-base oil stage.

#### Reagents:

- Crude reaction mixture
- Oxalic acid (anhydrous) or HCl (4M in Dioxane)
- Solvents: Ethanol (EtOH), Diethyl Ether (Et<sub>2</sub>O)

#### Step-by-Step:

- Filtration: If the crude mixture contains solids, filter through Celite.
- Dilution: Dilute the crude filtrate with Et<sub>2</sub>O or EtOAc (10 volumes).
- Acid Addition:
  - For Oxalates: Add a saturated solution of Oxalic acid in EtOH dropwise at 0°C.
  - For HCl: Add HCl/Dioxane dropwise at 0°C.
- Precipitation: A white solid should precipitate immediately.
- Ripening: Stir at 0°C for 30 minutes. Do not warm up.
- Collection: Filter the solid. Wash with cold Et<sub>2</sub>O.
- Drying: Dry under high vacuum at room temperature (do not heat).

## Protocol 2: The "Salting-Out" Extraction (For Free Bases)

Use this only if you must isolate the free base for the next step.

#### Step-by-Step:

- Quench: Cool reaction to 0°C.
- Basify: Add saturated aqueous K<sub>2</sub>CO<sub>3</sub> until pH > 12. (Avoid NaOH if ester groups are present, but K<sub>2</sub>CO<sub>3</sub> is usually safe).

- Saturation: Add solid  $K_2CO_3$  until no more dissolves (supersaturation). This forces the organic amine out of the water phase.
- Extraction: Extract 4x with DCM:Isopropanol (3:1).
- Drying: Dry organic layer over  $Na_2SO_4$  (Sodium Sulfate). Avoid  $MgSO_4$  as it is slightly Lewis acidic.
- Concentration: Concentrate at  $< 30^\circ C$  bath temperature. Do not go to dryness. Use the concentrated solution directly in the next step.

## Stability Data & Solvent Compatibility

Parameter	Free Base (Oil)	HCl Salt (Solid)	Oxalate Salt (Solid)
Thermal Stability	Low (Polymerizes $>40^\circ C$ )	High ( $>150^\circ C$ )	High ( $>150^\circ C$ )
Shelf Life (RT)	$< 24$ Hours	$> 1$ Year	$> 1$ Year
Hygroscopicity	N/A (Liquid)	Moderate	Low (Preferred)
Recrystallization	N/A	MeOH/Et <sub>2</sub> O	EtOH/Water

## Workflow Decision Tree

Follow this logic to determine the correct workup path.

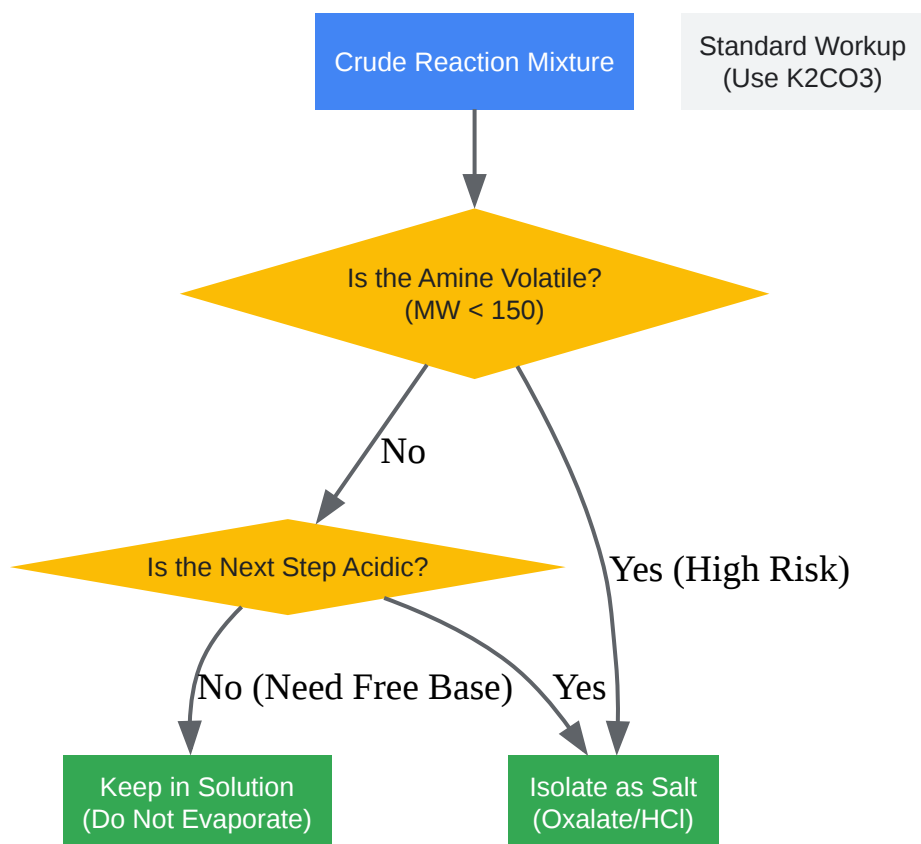

[Click to download full resolution via product page](#)

Figure 2: Decision logic for handling spirocyclic amines based on volatility and downstream utility.

## Frequently Asked Questions (FAQ)

Q: Can I use Silica Gel chromatography for purification? A: Proceed with caution. Silica is acidic. Free spiro-amines can streak or decompose on the column.

- Fix: Pre-treat the silica column with 1% Triethylamine (TEA) in the eluent to neutralize acidic sites. Use basic alumina if the compound is highly acid-sensitive.

Q: Why did my yield drop when I used high vacuum? A: Many small spirocyclic amines (e.g., 2-azaspiro[3.3]heptane) are sublimable or volatile solids/oils.

- Fix: Do not use high vacuum (< 5 mbar) for extended periods on the free base. If you must remove solvent, use a controlled vacuum and keep the flask cold.

Q: Which salt is better: HCl or TFA? A: HCl is generally preferred for biological testing. TFA salts are often hygroscopic and can be difficult to handle (forming oils instead of solids). However, TFA salts are easier to obtain if purifying via Reverse Phase HPLC. For storage, convert TFA salts to HCl or Oxalate.

## References

- Polymerization Mechanism: Goethals, E. J. "Cationic Ring-Opening Polymerization of Azetidines." *Polymer Chemistry*, 2015.[6]
- Spirocyclic Amine Synthesis & Handling: Burkhard, J. A., et al. "Synthesis and Structural Analysis of Spiro[3.3]heptanes as Rigidified Piperidine Derivatives." *Organic Letters*, 2010.
- Workup Strategies: "Green Chromatography and Extraction Decision Tree." ACS GCI Pharmaceutical Roundtable, 2016.[2]
- Salt Stability: Wuitschik, G., et al. "Spirocyclic Motifs in Drug Discovery." *Nature Chemistry*, 2015. (Discusses the physicochemical properties and stability of spiro-scaffolds).

### *Need Custom Synthesis?*

*BenchChem offers custom synthesis for rare earth carbides and specific isotopic labeling.*

*Email: [info@benchchem.com](mailto:info@benchchem.com) or [Request Quote Online](#).*

## Sources

- [1. researchgate.net](https://www.researchgate.net) [researchgate.net]
- [2. MedChem Tips and Tricks – ACSGCIPR](https://www.acsgcipr.org) [acsgcipr.org]
- [3. pubs.acs.org](https://pubs.acs.org) [pubs.acs.org]
- [4. Prediction of Thermal and Oxidative Degradation of Amines to Improve Sustainability of CO2 Absorption Process](https://www.mdpi.com) [mdpi.com]
- [5. Chemical Stability and Characterization of Degradation Products of Blends of 1-\(2-Hydroxyethyl\)pyrrolidine and 3-Amino-1-propanol - PMC](https://pubmed.ncbi.nlm.nih.gov) [pmc.ncbi.nlm.nih.gov]
- [6. researchgate.net](https://www.researchgate.net) [researchgate.net]

- To cite this document: BenchChem. [Preventing polymerization of spirocyclic amines during workup]. BenchChem, [2026]. [Online PDF]. Available at: [<https://www.benchchem.com/product/b3393127/docs#preventing-polymerization-of-spirocyclic-amines-during-workup>]

---

### Disclaimer & Data Validity:

The information provided in this document is for Research Use Only (RUO) and is strictly not intended for diagnostic or therapeutic procedures. While BenchChem strives to provide accurate protocols, we make no warranties, express or implied, regarding the fitness of this product for every specific experimental setup.

**Technical Support:** The protocols provided are for reference purposes. Unsure if this reagent suits your experiment?

**Need Industrial/Bulk Grade?** [Request Custom Synthesis Quote](#)

## BenchChem

Our mission is to be the trusted global source of essential and advanced chemicals, empowering scientists and researchers to drive progress in science and industry.

### Contact

Address: 3281 E Guasti Rd  
Ontario, CA 91761, United States  
Phone: (601) 213-4426  
Email: [info@benchchem.com](mailto:info@benchchem.com)

[Contact our Ph.D. Support Team for a compatibility check](#)