

# Comparative Reactivity Guide: 2,5-Dimethyl vs. 2,4-Dimethyl Phenoxyethanones

**Author:** BenchChem Technical Support Team. **Date:** May 2026

## Compound of Interest

Compound Name: 2-(2,5-Dimethylphenoxy)-1-phenylethanone

Cat. No.: B339277

[Get Quote](#)

## Executive Summary

In the landscape of heterocyclic synthesis, 2,4-dimethylphenoxyethanone and 2,5-dimethylphenoxyethanone serve as critical isomeric precursors for substituted benzofurans. While chemically similar, their reactivity profiles diverge significantly due to steric ortho-effects during cyclization.

- 2,4-Dimethylphenoxyethanone: Exhibits high reactivity in acid-mediated cyclodehydration. It cyclizes readily to form 5,7-dimethylbenzofuran in high yields (>80%) because the site of ring closure is sterically unencumbered.
- 2,5-Dimethylphenoxyethanone: Exhibits inhibited reactivity. Its cyclization to 4,7-dimethylbenzofuran is sterically hindered by the 5-methyl group (which becomes the 4-position in benzofuran). This transformation often requires harsher conditions, results in lower yields (30–60%), or necessitates alternative synthetic routes to avoid "buttressing" effects.

## Structural Analysis & Mapping

To understand the reactivity difference, one must map the atom positions from the phenoxy precursor to the benzofuran product. The critical factor is the environment of the ortho-carbon (C6) of the phenoxy ring, where the new C-C bond forms.

Precursor Isomer	Phenoxy Substituents	Reactive Site (C6) Environment	Benzofuran Product	Steric Status
2,4-Dimethyl	2-Me, 4-Me	Flanked by H (at C5) and O (at C1)	5,7-Dimethylbenzofuran	Unhindered
2,5-Dimethyl	2-Me, 5-Me	Flanked by Me (at C5) and O (at C1)	4,7-Dimethylbenzofuran	Hindered

## Reaction Pathway Visualization

The following diagram illustrates the mechanistic divergence. The red "X" indicates the steric clash in the 2,5-isomer pathway.

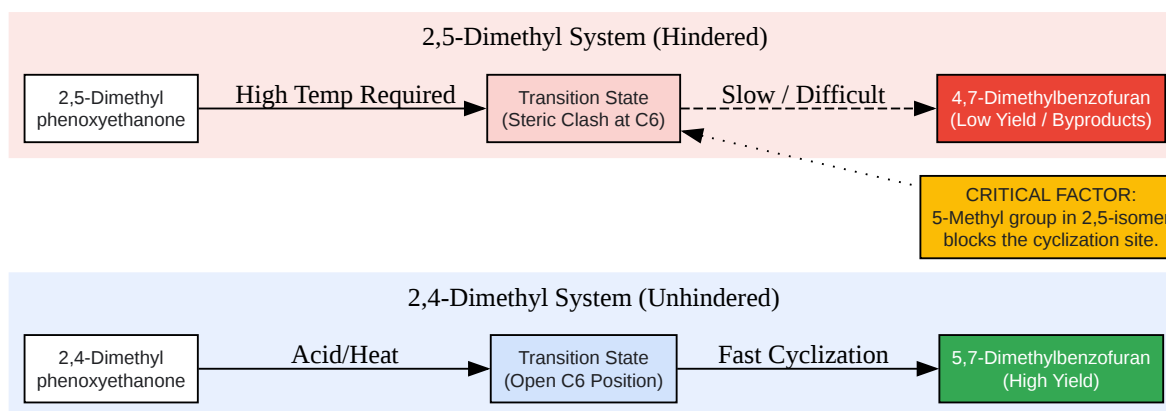

[Click to download full resolution via product page](#)

Figure 1: Mechanistic pathway comparison showing the steric blockade in the 2,5-dimethyl system.

## Detailed Reactivity Profile

### A. Cyclodehydration (Benzofuran Synthesis)

This is the primary reaction for these molecules. The standard protocol involves heating with Polyphosphoric Acid (PPA) or Amberlyst-15.

- 2,4-Dimethylphenoxyethanone: The cyclization targets the C6 position. In this isomer, C5 is occupied by a Hydrogen atom. The electrophilic attack of the carbonyl carbon onto C6 encounters minimal steric resistance.
  - Experimental Outcome: Clean conversion, typically complete within 1-2 hours at 80-100°C.
  - Yield: 80–92%.
- 2,5-Dimethylphenoxyethanone: The cyclization also targets C6. However, C5 is occupied by a Methyl group. This creates a peri-interaction (1,2-steric strain) in the transition state. The incoming carbonyl carbon must squeeze between the oxygen and the bulky 5-methyl group.
  - Experimental Outcome: Reaction is sluggish. Often requires temperatures >120°C. Competitive side reactions (polymerization, intermolecular condensation) increase.
  - Yield: 30–60% (often requires purification from isomers formed via methyl migration).

### B. Electrophilic Aromatic Substitution (EAS)

Apart from cyclization, the rings react differently to external electrophiles (e.g., bromination, nitration).

- 2,4-Dimethyl: The C6 position is activated by the ether oxygen (ortho) but is meta to both methyl groups. It is the most reactive site but less activated than in the 2,5-isomer electronically.

- 2,5-Dimethyl: The C4 position is para to the ether oxygen and ortho to the 5-methyl group. It is highly activated. However, for cyclization (which must happen at C6), the electronic activation (C6 is ortho to 5-Me and ortho to O) is counteracted by the severe steric hindrance.

## Experimental Protocols

### Protocol A: Synthesis of Phenoxyethanones (Precursors)

Applicable to both isomers.

- Reagents: 2,4-dimethylphenol (or 2,5-dimethylphenol), Chloroacetone, , Acetone (solvent).
- Procedure:
  - Dissolve 10 mmol of the phenol in 30 mL dry acetone.
  - Add 15 mmol anhydrous . Stir for 15 min.
  - Add 12 mmol Chloroacetone dropwise.
  - Reflux for 4–6 hours. Monitor by TLC (Hexane:EtOAc 4:1).
  - Filter salts, evaporate solvent, and recrystallize from ethanol.
- Self-Validation: Product should show a singlet (~4.6 ppm) for in NMR.

### Protocol B: Cyclization to Benzofurans (PPA Method)

Note the condition differences.

Parameter	2,4-Dimethyl Isomer	2,5-Dimethyl Isomer
Reagent	Polyphosphoric Acid (PPA)	Polyphosphoric Acid (PPA)
Ratio (w/w)	1:5 (Substrate:PPA)	1:10 (Substrate:PPA)
Temperature	80–90°C	130–150°C
Time	1.5 Hours	4–6 Hours
Workup	Pour into ice water, extract with ether.	Pour into ice water, extract, column chromatography required.
Expected Yield	85% (5,7-dimethylbenzofuran)	45% (4,7-dimethylbenzofuran)

#### Step-by-Step Procedure (2,5-Isomer Specific Optimization):

- Mix 1.0 g of 2,5-dimethylphenoxyethanone with 10 g of PPA in a round-bottom flask.
- Heat to 140°C with vigorous mechanical stirring (magnetic stirring may fail due to viscosity).
- Monitor every 30 mins. If blackening occurs (charring), reduce temp to 120°C and extend time.
- Quench by pouring the hot syrup onto 100 g of crushed ice. Stir until PPA hydrolyzes.
- Extract with Diethyl Ether ( mL). Wash organic layer with (sat.) to remove acidic impurities.
- Crucial Step: Purify via silica gel chromatography (Eluent: Hexane 100% Hexane:EtOAc 98:2) to separate the product from unreacted starting material and polymeric byproducts.

## Comparative Data Summary

The following table summarizes the physicochemical and reactivity differences.

Feature	2,4-Dimethyl Phenoxyethanone	2,5-Dimethyl Phenoxyethanone
Primary Cyclization Product	5,7-Dimethylbenzofuran	4,7-Dimethylbenzofuran
Cyclization Barrier	Low (Kinetic control)	High (Steric hindrance)
Reaction Temperature	Mild (<100°C)	Harsh (>130°C)
Major Byproducts	Minimal	Polymers, Rearrangement products
Biological Relevance	Precursor to standard benzofuran scaffolds	Precursor to 4,7-dimethylbenzofuran (potent HIV-1 inhibitor)
NMR Characteristic	C6-H is a singlet/doublet (unhindered)	C6-H is absent in product; C4-Me shows NOE with C3-H

## References

- Synthesis of Benzofurans via Acid Catalyzed Cyclization. Organic Chemistry Portal. Available at: [\[Link\]](#)
- Regioselective Synthesis of Benzofuranones and Benzofurans. Journal of Organic Chemistry, 2021.<sup>[1]</sup> (Discusses difficulty of 4,7-disubstituted synthesis). Available at: [\[Link\]](#)<sup>[1]</sup>
- The synthesis and investigation of novel 3-benzoylbenzofurans. NIH / PubMed Central. (Highlights 4,7-dimethylbenzofuran as a potent inhibitor and its synthetic route). Available at: [\[Link\]](#)
- Highly substituted benzo[b]furan synthesis through substituent migration. RSC Advances, 2024. (Details the migration mechanisms in hindered phenols). Available at: [\[Link\]](#)
- PubChem Compound Summary: 2-Phenoxy-1-phenylethanone. National Library of Medicine. Available at: [\[Link\]](#)

### Need Custom Synthesis?

BenchChem offers custom synthesis for rare earth carbides and specific isotopic labeling.

Email: [info@benchchem.com](mailto:info@benchchem.com) or [Request Quote Online](#).

## Sources

- 1. [beaudry.chem.oregonstate.edu](http://beaudry.chem.oregonstate.edu) [[beaudry.chem.oregonstate.edu](http://beaudry.chem.oregonstate.edu)]
- To cite this document: BenchChem. [Comparative Reactivity Guide: 2,5-Dimethyl vs. 2,4-Dimethyl Phenoxyethanones]. BenchChem, [2026]. [Online PDF]. Available at: [<https://www.benchchem.com/product/b339277/docs#comparative-reactivity-guide-2-5-dimethyl-vs-2-4-dimethyl-phenoxyethanones>]

### Disclaimer & Data Validity:

The information provided in this document is for Research Use Only (RUO) and is strictly not intended for diagnostic or therapeutic procedures. While BenchChem strives to provide accurate protocols, we make no warranties, express or implied, regarding the fitness of this product for every specific experimental setup.

**Technical Support:** The protocols provided are for reference purposes. Unsure if this reagent suits your experiment?

**Need Industrial/Bulk Grade?** [Request Custom Synthesis Quote](#)

## BenchChem

Our mission is to be the trusted global source of essential and advanced chemicals, empowering scientists and researchers to drive progress in science and industry.

### Contact

Address: 3281 E Guasti Rd

Ontario, CA 91761, United States

Phone: (601) 213-4426

Email: [info@benchchem.com](mailto:info@benchchem.com)

Contact our Ph.D. Support Team for a compatibility check