

Technical Guide: Alpha-Substituted Caprolactam Building Blocks in Medicinal Chemistry

Author: BenchChem Technical Support Team. **Date:** April 2026

Compound of Interest

Compound Name: Ethyl 2-(2-oxoazepan-3-yl)acetate

CAS No.: 831-32-3

Cat. No.: B3387471

[Get Quote](#)

Executive Summary

The

-caprolactam scaffold (hexahydro-2H-azepin-2-one) is far more than an industrial monomer for Nylon-6. In the context of modern drug discovery,

-substituted caprolactams serve as privileged building blocks for peptidomimetics. By incorporating the

-carbon of an amino acid into a seven-membered lactam ring, medicinal chemists can rigidly constrain the

(psi) and

(phi) torsion angles of the peptide backbone. This conformational restriction is critical for stabilizing secondary structures (such as

-turns) and enhancing proteolytic stability.

This guide details the synthetic architecture, stereochemical considerations, and experimental protocols for generating high-value

-functionalized caprolactam cores, specifically focusing on

-amino,

-alkyl, and

-hydroxy derivatives.

Structural Logic & Pharmacophore Utility

The Conformational "Lock"

In a linear peptide, the L-lysine side chain has significant motional freedom. Cyclization to

-amino-

-caprolactam (also known as the Lysine Lactam) locks the side chain into a specific spatial orientation while simultaneously restricting the backbone geometry.

- Peptidomimetics: The scaffold mimics the

or

positions of

-turns.

- Protease Stability: The cyclic amide is resistant to standard exopeptidases, extending the half-life of peptide-based drugs.

- Lysine Surrogates: The amine handle at the

-position allows for further functionalization (acylation, alkylation) to mimic extended peptide chains.

Classification of Building Blocks

Class	Substituent (-position)	Primary Application	Key Precursor
Class A	Amino ()	Peptidomimetics, Lysine surrogates	L-Lysine
Class B	Alkyl / Aryl ()	Hydrophobic core modification, Anticonvulsants	Caprolactam / Cyclohexanone
Class C	Hydroxy ()	Transition state mimics (Protease inhibitors)	-Halo-caprolactam

Synthetic Methodologies

Strategy A: The Chiral Pool Approach (From L-Lysine)

The most direct route to enantiopure

-amino-caprolactam is the cyclization of L-lysine. This method preserves the stereochemistry of the natural amino acid.

- Mechanism: Intramolecular amidation.
- Challenge: Preventing polymerization (oligomerization) vs. cyclization.
- Solution: High dilution conditions or the use of specific solvents (e.g., alcohols with high boiling points) to favor intramolecular reaction.

Strategy B: The De Novo Approach (Beckmann Rearrangement)

For

-alkyl or

-aryl derivatives, the Beckmann rearrangement of 2-substituted cyclohexanone oximes is the standard.

- Regioselectivity Rule: The group anti (trans) to the hydroxyl of the oxime migrates.^[1]
- Critical Insight: 2-substituted cyclohexanones form two oxime geometric isomers (and).
 - Isomer A (Hydroxyl anti to alkyl): Migration of the substituted carbon -substituted caprolactam.
 - Isomer B (Hydroxyl syn to alkyl): Migration of the methylene carbon -substituted caprolactam (often unwanted).
- Control: Bulky substituents or specific Lewis acids can influence the ratio of the oxime formation, thereby controlling the final lactam regiochemistry.

Strategy C: Direct -Functionalization (Enolate Chemistry)

Direct alkylation of the parent caprolactam requires protection of the lactam nitrogen to prevent -alkylation.

- Protection:
 - Boc or
 - Trimethylsilyl (TMS) protection.
- Deprotonation: Use of Lithium Diisopropylamide (LDA) or LiHMDS at -78°C to form the thermodynamic enolate.
- Electrophile Trapping: Addition of alkyl halides.

Visualization of Synthetic Logic[2]

The following diagram illustrates the divergent pathways for synthesizing these building blocks, highlighting the regiochemical pivot point in the Beckmann rearrangement.

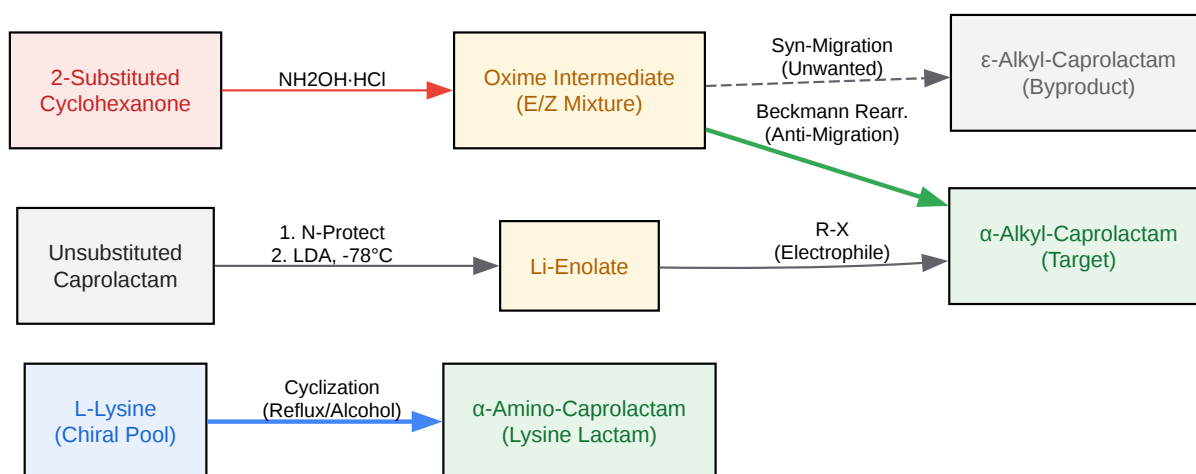

[Click to download full resolution via product page](#)

Caption: Divergent synthetic pathways. The Lysine route preserves chirality; the Beckmann route requires regiocontrol; Direct alkylation offers modular diversity.

Experimental Protocols

Protocol 1: Synthesis of L- -Amino- -Caprolactam (Lysine Lactam)

Rationale: This protocol utilizes a high-boiling solvent to drive the equilibrium toward cyclization while removing water.

Materials:

- L-Lysine Monohydrochloride (100 mmol)
- Sodium Hydroxide (100 mmol)
- 1-Hexanol (Solvent)

- Dean-Stark apparatus[2]

Step-by-Step:

- Neutralization: Suspend L-Lysine HCl (18.26 g) in 1-Hexanol (200 mL). Add NaOH (4.0 g) to generate the free base in situ.
- Reflux: Heat the mixture to reflux (~157°C). The reaction relies on the thermodynamic stability of the 7-membered lactam.
- Water Removal: Use a Dean-Stark trap to continuously remove the water generated by the condensation.[2] Monitor for cessation of water evolution (approx. 12-24 hours).
- Work-up: Cool the reaction to room temperature. Filter off the NaCl byproduct.[2]
- Isolation: Concentrate the filtrate under reduced pressure.
- Purification: Recrystallize the crude residue from Acetone/Ethanol to yield white crystals.
- Validation: Check optical rotation

• A value near -26° (c=1, water) confirms the retention of the L-configuration (S-enantiomer).

Protocol 2: Direct -Alkylation of -Caprolactam

Rationale: Direct functionalization allows for the rapid generation of libraries. N-protection is mandatory to prevent N-alkylation.

Materials:

- -Caprolactam[2][3][4][5]
- Di-tert-butyl dicarbonate ()
- Lithium Diisopropylamide (LDA) - 2.0M in THF
- Benzyl Bromide (Electrophile)

- THF (Anhydrous)

Step-by-Step:

- N-Protection: Dissolve caprolactam (10 mmol) in DCM. Add (11 mmol) and DMAP (catalytic). Stir 4h. Wash with 1N HCl, brine, dry, and concentrate to yield -Boc-caprolactam.
- Enolization: In a flame-dried flask under Argon, dissolve -Boc-caprolactam (5 mmol) in anhydrous THF (20 mL). Cool to -78°C (Dry ice/Acetone bath).
- Deprotonation: Add LDA (5.5 mmol) dropwise over 10 minutes. The solution typically turns faint yellow, indicating enolate formation. Stir for 45 minutes at -78°C.
- Alkylation: Add Benzyl Bromide (6 mmol) dropwise.
- Warm-up: Allow the reaction to warm slowly to 0°C over 2 hours.
- Quench: Quench with saturated solution.
- Extraction: Extract with EtOAc (3x). Dry organic layers over .
- Deprotection (Optional): If the free lactam is required, treat with TFA/DCM (1:1) for 1 hour.

Key Applications in Drug Discovery[2][5][8]

Peptidomimetics & Foldamers

-amino-caprolactam is a cornerstone in the design of "constrained peptides." By replacing a flexible residue with this scaffold, researchers can induce specific turn geometries.

- Example: It has been used to mimic the Ala-Pro turn in bioactive peptides, locking the conformation to increase receptor affinity.

Anticonvulsants

Derivatives substituted at the

-position show significant activity in modulating ion channels.

- Compound of Interest:

-hydroxy-

-phenylcaprolactam.[6]

- Mechanism: Modulation of GABAergic transmission. The lipophilic phenyl group at the

-position aids in blood-brain barrier penetration.

Bengamide Analogues (Antitumor)

The Bengamides are natural products with potent antitumor activity. The caprolactam ring serves as a stable mimic of the susceptible ester linkage found in some natural analogues, improving metabolic stability while retaining cytotoxicity against cancer cell lines.

References

- BenchChem. The Chemistry of Caprolactam Derivatives: A Technical Guide for Drug Development Professionals. (Accessed 2024). [Link](#)
- Guo, S., et al. "Clean Beckmann rearrangement of cyclohexanone oxime in caprolactam-based Brønsted acidic ionic liquids." [7] *Green Chemistry*, 2006, 8, 296-300. [7] [Link](#)
- European Patent Office. Substituted caprolactam derivatives, process for preparing and pharmaceutical composition. [8] EP0049505A2. [8] [Link](#)
- Royal Society of Chemistry. "Synthesis and characterization of α -amino- ϵ -caprolactam (ACL)." *New Journal of Chemistry*, Supplementary Info. [2] [Link](#)
- Macmillan Group. "Direct, enantioselective α -alkylation of aldehydes using simple olefins." (Contextual reference for alpha-functionalization logic). *Nature*, 2017. [Link](#)

Need Custom Synthesis?

BenchChem offers custom synthesis for rare earth carbides and specific isotopic labeling.

Email: info@benchchem.com or [Request Quote Online](#).

Sources

- [1. scribd.com \[scribd.com\]](https://www.scribd.com)
- [2. rsc.org \[rsc.org\]](https://www.rsc.org)
- [3. pdf.benchchem.com \[pdf.benchchem.com\]](https://pdf.benchchem.com)
- [4. WO2012040646A2 - Method for making alpha-amino-epsilon-caprolactam using mixed super critical fluids - Google Patents \[patents.google.com\]](#)
- [5. Conformational studies on substituted \$\epsilon\$ -caprolactams by X-ray crystallography and NMR spectroscopy - New Journal of Chemistry \(RSC Publishing\) DOI:10.1039/C4NJ01339E \[pubs.rsc.org\]](#)
- [6. pdf.benchchem.com \[pdf.benchchem.com\]](https://pdf.benchchem.com)
- [7. Clean Beckmann rearrangement of cyclohexanone oxime in caprolactam-based Brønsted acidic ionic liquids - Green Chemistry \(RSC Publishing\) \[pubs.rsc.org\]](#)
- [8. data.epo.org \[data.epo.org\]](https://data.epo.org)
- To cite this document: BenchChem. [Technical Guide: Alpha-Substituted Caprolactam Building Blocks in Medicinal Chemistry]. BenchChem, [2026]. [Online PDF]. Available at: [\[https://www.benchchem.com/product/b3387471/docs#technical-guide-alpha-substituted-caprolactam-building-blocks-in-medicinal-chemistry\]](https://www.benchchem.com/product/b3387471/docs#technical-guide-alpha-substituted-caprolactam-building-blocks-in-medicinal-chemistry)

Disclaimer & Data Validity:

The information provided in this document is for Research Use Only (RUO) and is strictly not intended for diagnostic or therapeutic procedures. While BenchChem strives to provide accurate protocols, we make no warranties, express or implied, regarding the fitness of this product for every specific experimental setup.

Technical Support: The protocols provided are for reference purposes. Unsure if this reagent suits your experiment?

Need Industrial/Bulk Grade? [Request Custom Synthesis Quote](#)

BenchChem

Our mission is to be the trusted global source of essential and advanced chemicals, empowering scientists and researchers to drive progress in science and industry.

Contact

Address: 3281 E Guasti Rd
Ontario, CA 91761, United States
Phone: (601) 213-4426
Email: info@benchchem.com

[Contact our Ph.D. Support Team for a compatibility check](#)