

Technical Guide: Mass Spectrometric Verification of 4-(2,3-Dichlorophenoxy)butanoic Acid

Author: BenchChem Technical Support Team. **Date:** April 2026

Compound of Interest

Compound Name:	4-(2,3-Dichlorophenoxy)butanoic acid
CAS No.:	7170-59-4
Cat. No.:	B3386242

[Get Quote](#)

Executive Summary

This guide provides a rigorous framework for the identification and structural verification of **4-(2,3-Dichlorophenoxy)butanoic acid** (2,3-DB), a structural isomer of the common herbicide 2,4-DB. While often overshadowed by its 2,4-isomer, 2,3-DB appears in environmental surveillance and impurity profiling of phenoxy herbicides.

The Core Challenge: 2,3-DB and 2,4-DB share identical molecular formulas (

) and nominal masses. Mass spectrometry (MS) alone often yields identical fragment ions. Therefore, verification requires a dual-approach: chromatographic resolution coupled with specific fragmentation pathways.

This guide compares the two "Gold Standard" workflows:

- GC-MS (EI): High structural specificity via library matching (requires derivatization).

- LC-MS/MS (ESI-): High throughput, direct analysis of polar acids.

Molecular Profile & Theoretical Mass Data

Before initiating analysis, the theoretical mass envelope must be established to validate instrument calibration.

Feature	Data	Notes
Formula		Dichlorinated phenoxy ether with butyric acid tail.[1]
Monoisotopic Mass	248.0007 Da	Based on .
Isotope Pattern	9:6:1 (M : M+2 : M+4)	Characteristic of two Chlorine atoms.
Target Isomer	2,3-Substitution	Critical: Ortho-Meta substitution creates steric crowding different from the 2,4-isomer.

Comparative Analysis: GC-MS (EI) vs. LC-MS/MS (ESI)

Technique A: GC-MS (Electron Impact) – The Structural Fingerprint

Best for: Confirmatory analysis, library matching, and complex matrix profiling.

The Protocol: Phenoxy acids are non-volatile and polar. Direct injection leads to peak tailing and thermal degradation. Derivatization to the Methyl Ester is mandatory for reliable fragmentation.

- Derivatization: Methylation (Diazomethane or).
- Analyte Form: **4-(2,3-Dichlorophenoxy)butanoic acid** methyl ester ().

- New MW: 262.02 Da.

Fragmentation Logic (EI, 70eV):

- Molecular Ion (): Visible but weak at m/z 262.
- McLafferty Rearrangement: The butyric acid chain allows for a 6-membered transition state. However, the ether oxygen dominates charge retention.
- Primary Cleavage (Base Peak): Rupture of the ether bond or the alkyl chain.
 - m/z 162/164: 2,3-Dichlorophenol ion (The aromatic ring retains the charge).
 - m/z 101: Loss of the dichlorophenoxy group (butyric ester chain fragment).
 - m/z 59: Carbomethoxy group ().

“

Expert Insight: In the 2,3-isomer, the chlorine at the 2-position (ortho) creates steric hindrance near the ether linkage. Expect a slightly lower abundance of the molecular ion compared to the 2,4-isomer due to faster ether cleavage.

Technique B: LC-MS/MS (Electrospray Ionization) – The Kinetic Solution

Best for: High-throughput quantification, water analysis, and avoiding derivatization.

The Protocol: Direct injection into a C18 column using negative mode ESI.[\[2\]](#)

- Ionization: ESI Negative Mode (

).

- Precursor Ion:m/z 247.0 (Monoisotopic).

Fragmentation Logic (CID - Collision Induced Dissociation):

- Precursor: m/z 247.0 (stable phenoxyacetate anion).
- Primary Transition (Quantifier): Cleavage of the ether bond.
 - m/z 247
161: Formation of 2,3-Dichlorophenoxide anion.
 - Mechanism:[3][4][5][6] The ether bond breaks; the aromatic ring stabilizes the negative charge better than the aliphatic chain.
- Secondary Transition (Qualifier):
 - m/z 247
203: Loss of
(44 Da) from the carboxylic acid tail.
 - Note: This transition is often less intense than the ether cleavage.

Head-to-Head Comparison

Feature	GC-MS (Methyl Ester)	LC-MS/MS (ESI Negative)
Selectivity	High (Isomer resolution via column chemistry + spectral fingerprint).	Medium (MRM transitions are identical for 2,3- and 2,4-DB; relies on RT).
Sensitivity	Good (pg levels), but limited by derivatization efficiency.	Excellent (fg levels), highly ionizable acidic group.
Sample Prep	Complex: Requires extraction + methylation (Time: >1 hr).	Simple: Dilute-and-shoot or SPE (Time: <15 min).
Fragmentation	Hard (70eV): Rich pattern, library searchable (NIST).	Soft: Precursor dominant; requires CID for fragments.
Isomer Risk	Low: Capillary GC separates 2,3- and 2,4- isomers efficiently.	High: C18 columns may co-elute isomers without optimization.

Fragmentation Mechanisms & Pathways

The following diagram illustrates the distinct fragmentation pathways for both ionization modes.

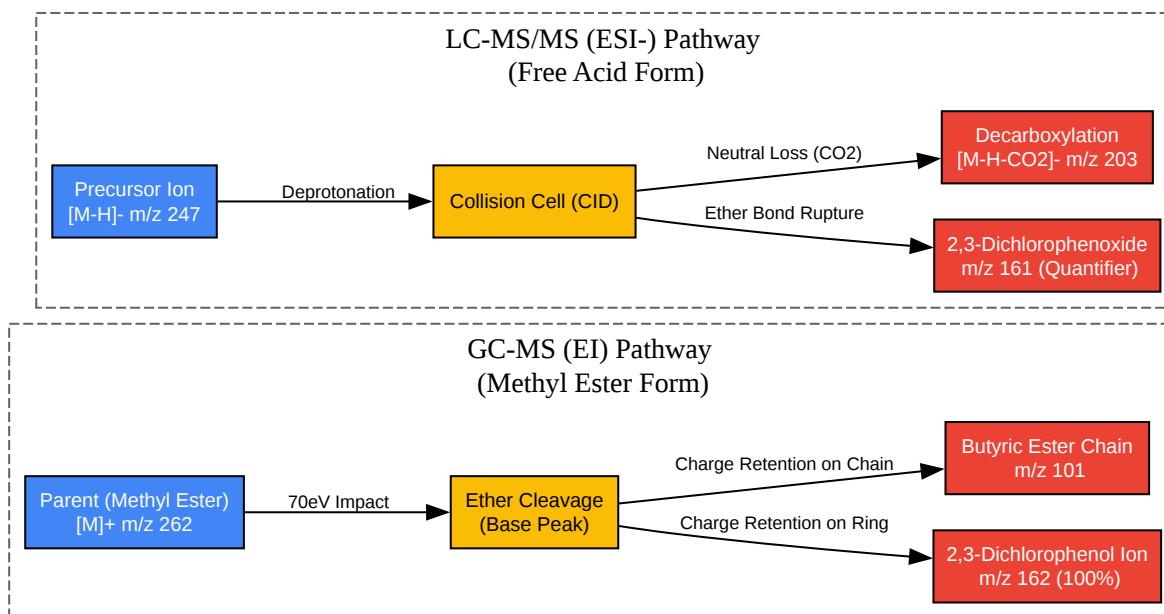

[Click to download full resolution via product page](#)

Caption: Figure 1. Dual-mode fragmentation pathways. GC-MS (top) favors radical cation formation and ether cleavage. LC-MS (bottom) favors even-electron anion formation and heterolytic cleavage.

Experimental Protocol: The Self-Validating Workflow

To ensure scientific integrity, this protocol includes "Stop/Go" validation steps.

Phase 1: Sample Preparation (LC-MS Focus)

Rationale: We prioritize the LC-MS workflow for its speed, using GC-MS only for isomer confirmation.

- Extraction: Acidify 10 mL aqueous sample to pH 2 with

- SPE Enrichment: Use Polymeric Weak Anion Exchange (WAX) cartridges.
 - Why WAX? It captures the acidic moiety of 2,3-DB selectively over neutral interferences.
- Elution: Elute with 5%

in Methanol.
- Reconstitution: Evaporate to dryness; reconstitute in 90:10 Water:MeOH.

Phase 2: Instrument Setup (LC-QTOF or Triple Quad)

- Column: C18 Core-Shell (2.1 x 100mm, 1.7 μ m).
 - Critical Setting: Use a shallow gradient (e.g., 5% to 95% B over 15 mins) to separate the 2,3-isomer from the 2,4-isomer.
- Mobile Phase:
 - A: Water + 0.01% Formic Acid (Keep acid low to prevent signal suppression in negative mode).
 - B: Acetonitrile.[\[2\]](#)[\[7\]](#)

Phase 3: Validation Criteria (The "Trust" Check)

Before reporting data, verify these three parameters:

- Retention Time Lock: Inject authentic 2,4-DB standard. The 2,3-DB isomer should elute slightly later (typically) due to the ortho-substitution affecting polarity, or earlier depending on the specific column selectivity for steric bulk. You must run a mix to define the Relative Retention Time (RRT).
- Ion Ratio: For LC-MS/MS, the ratio of m/z 161 (Quant) to m/z 203 (Qual) must be constant ($\pm 20\%$).
- Isotope Match: The precursor (m/z 247) must show the distinct 9:6:1 chlorine pattern.

Analytical Workflow Diagram

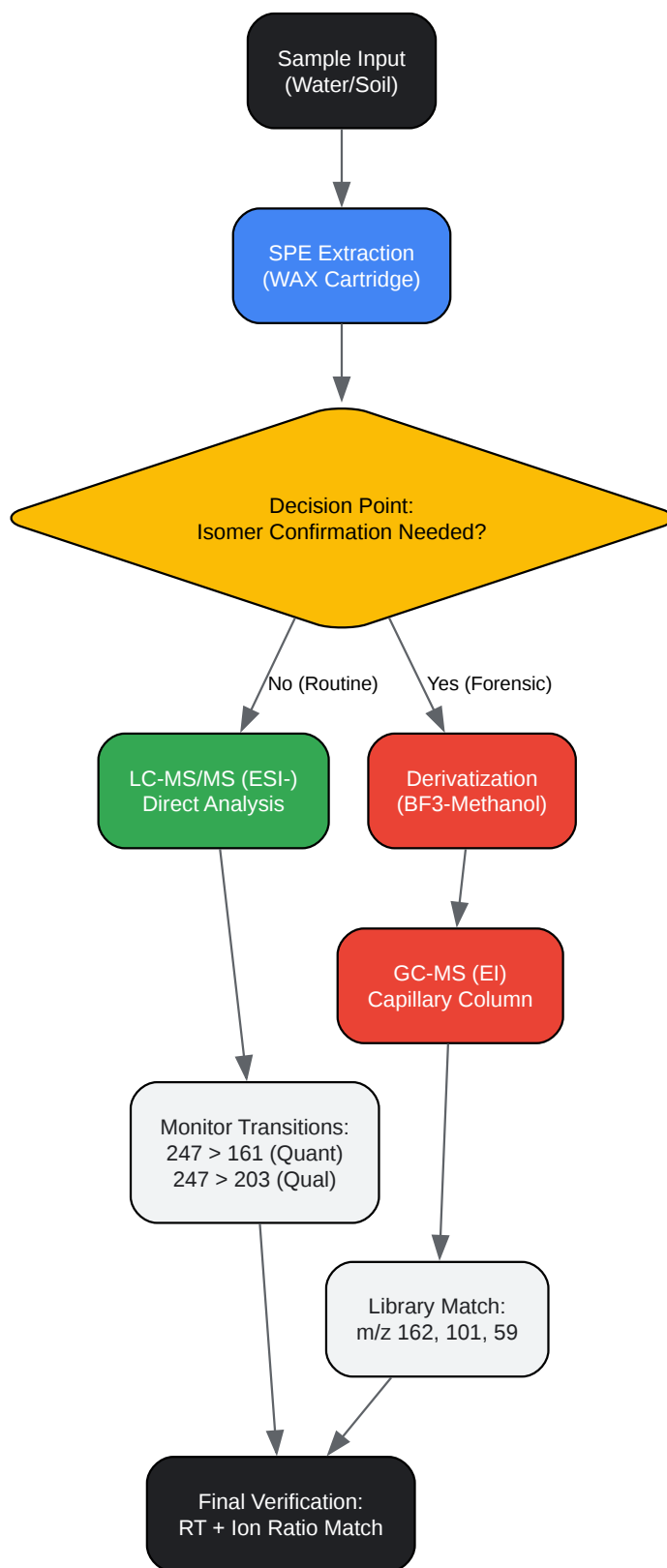

[Click to download full resolution via product page](#)

Caption: Figure 2. Decision matrix for selecting the analytical path. GC-MS is reserved for forensic isomer differentiation.

References

- US EPA Method 8151A.Chlorinated Herbicides by GC Using Methylation or Pentafluorobenzoylation Derivatization. U.S. Environmental Protection Agency.[8] [Link](#)
- NIST Chemistry WebBook.Mass Spectrum of Butanoic acid, 4-(2,4-dichlorophenoxy)- (Isomer Reference). National Institute of Standards and Technology. [Link](#)
- European Commission Reference Laboratories.Single Residue Methods for the Determination of Acidic Herbicides in Water and Soil. EURL-SRM. [Link](#)
- Journal of Chromatography A.Determination of phenoxy acid herbicides in water by LC-ESI-MS/MS. (General methodology grounding). [Link](#)

Need Custom Synthesis?

BenchChem offers custom synthesis for rare earth carbides and specific isotopic labeling.

Email: info@benchchem.com or [Request Quote Online](#).

Sources

- 1. Butanoic acid, 4-(2,4-dichlorophenoxy)- [webbook.nist.gov]
- 2. archivedproceedings.econference.io [archivedproceedings.econference.io]
- 3. 4-(2,4-Dichlorophenoxy)butyric acid | C₁₀H₁₀Cl₂O₃ | CID 1489 - PubChem [pubchem.ncbi.nlm.nih.gov]
- 4. researchgate.net [researchgate.net]
- 5. McLafferty Rearrangement - Chemistry Steps [chemistrysteps.com]
- 6. Optimization of Resolving Power, Fragmentation, and Mass Calibration in an Orbitrap Spectrometer for Analysis of 24 Pesticide Metabolites in Urine - PMC [pmc.ncbi.nlm.nih.gov]
- 7. researchgate.net [researchgate.net]
- 8. americanlaboratory.com [americanlaboratory.com]

- To cite this document: BenchChem. [Technical Guide: Mass Spectrometric Verification of 4-(2,3-Dichlorophenoxy)butanoic Acid]. BenchChem, [2026]. [Online PDF]. Available at: [<https://www.benchchem.com/product/b3386242/docs#technical-guide-mass-spectrometric-verification-of-4-2-3-dichlorophenoxy-butanoic-acid>]

Disclaimer & Data Validity:

The information provided in this document is for Research Use Only (RUO) and is strictly not intended for diagnostic or therapeutic procedures. While BenchChem strives to provide accurate protocols, we make no warranties, express or implied, regarding the fitness of this product for every specific experimental setup.

Technical Support: The protocols provided are for reference purposes. Unsure if this reagent suits your experiment?

Need Industrial/Bulk Grade? [Request Custom Synthesis Quote](#)

BenchChem

Our mission is to be the trusted global source of essential and advanced chemicals, empowering scientists and researchers to drive progress in science and industry.

Contact

Address: 3281 E Guasti Rd

Ontario, CA 91761, United States

Phone: (601) 213-4426

Email: info@benchchem.com

[Contact our Ph.D. Support Team for a compatibility check](#)