

# Application Note: Cysteine Labeling with Alpha-Chloroacetamide Probes

**Author:** BenchChem Technical Support Team. **Date:** April 2026

## Compound of Interest

Compound Name: 2-chloro-N-(2-methoxy-5-nitrophenyl)propanamide

CAS No.: 379254-91-8

Cat. No.: B3382922

[Get Quote](#)

## Executive Summary

This guide details the application of alpha-chloroacetamide ( $\alpha$ -CA) probes for chemoproteomic profiling and covalent ligand discovery. Unlike the hyper-reactive iodoacetamide (IA) warheads often used for total cysteine alkylation,  $\alpha$ -CA scaffolds offer "tunable" electrophilicity. This distinct reactivity profile makes them the preferred warhead for Targeted Covalent Inhibitors (TCIs) and Activity-Based Protein Profiling (ABPP), as they preferentially label nucleophilic, functional cysteines over structurally dormant ones.

This document provides the mechanistic basis, strategic considerations, and a validated isoTOP-ABPP protocol for mapping cysteine reactivity using  $\alpha$ -CA probes.

## Mechanistic Principles

### The "Goldilocks" Reactivity

Cysteine labeling relies on the nucleophilic attack of the thiolate anion (

) onto the electrophilic alpha-carbon of the probe. The reaction follows a bimolecular nucleophilic substitution (

) mechanism.

- Iodoacetamide (IA): Possesses an excellent leaving group (iodide). Reacts rapidly with almost all accessible cysteines, regardless of their pKa. Useful for total proteome mapping but lacks selectivity for functional sites.
- Alpha-Chloroacetamide ( $\alpha$ -CA): Chloride ( $\text{Cl}^-$ ) is a poorer leaving group than iodide. Consequently,  $\alpha$ -CA probes are less intrinsically reactive. They require a more nucleophilic cysteine (often lowered pKa due to local environment) to drive the reaction. This filters out "bystander" cysteines and enriches for catalytic or regulatory sites.

## Reaction Mechanism Diagram

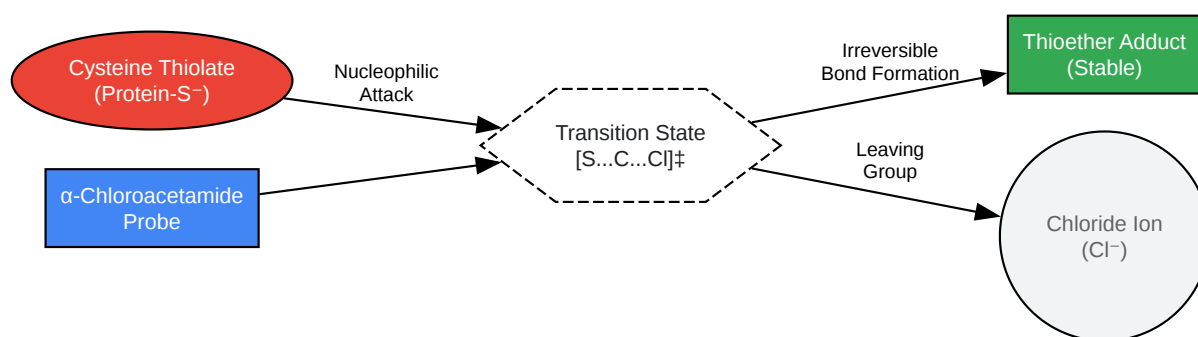

[Click to download full resolution via product page](#)

Figure 1:

reaction mechanism of cysteine thiolate attacking the alpha-chloroacetamide electrophile.

## Comparative Reactivity Data

The following table summarizes the reactivity profiles of common cysteine-reactive electrophiles used in chemical proteomics.

Warhead	Intrinsic Reactivity	Selectivity	Primary Application	Leaving Group Stability
Iodoacetamide (IA)	High	Low (Promiscuous)	Total Cysteine Mapping	Low (Iodide leaves easily)
- Chloroacetamide	Moderate (Tunable)	High (Functional Cys)	Ligand Discovery / TCI	Moderate
Acrylamide	Low to Moderate	High (Orientation dependent)	Kinase Inhibitors (e.g., Ibrutinib)	N/A (Michael Addition)
Maleimide	Very High	Moderate	Bioconjugation (ADCs)	N/A (Michael Addition)

## Protocol: Competitive isoTOP-ABPP

isotopic Tandem Orthogonal Proteolysis-Activity Based Protein Profiling

This protocol allows you to determine the specific cysteine residues targeted by an  $\alpha$ -CA probe (or a library of fragments) within a complex proteome.[1] It uses "competition" where a sample is pre-treated with a specific ligand, followed by a broad-spectrum probe (IA-alkyne) to label remaining sites.

## Reagents & Equipment

- Lysis Buffer: PBS, 0.1% Triton X-100, Protease Inhibitors (EDTA-free).
- Probe: IA-alkyne (Broad-spectrum "scout" probe).
- Competitor: Your specific  $\alpha$ -CA compound/fragment.
- Click Reagents: TBTA (Ligand),  
, TCEP (Reductant), Azide-TEV-Biotin (Heavy/Light isotopically labeled tags).
- Enrichment: Streptavidin-Agarose beads.
- Digestion: Sequencing grade Trypsin, TEV Protease.

## Workflow Diagram

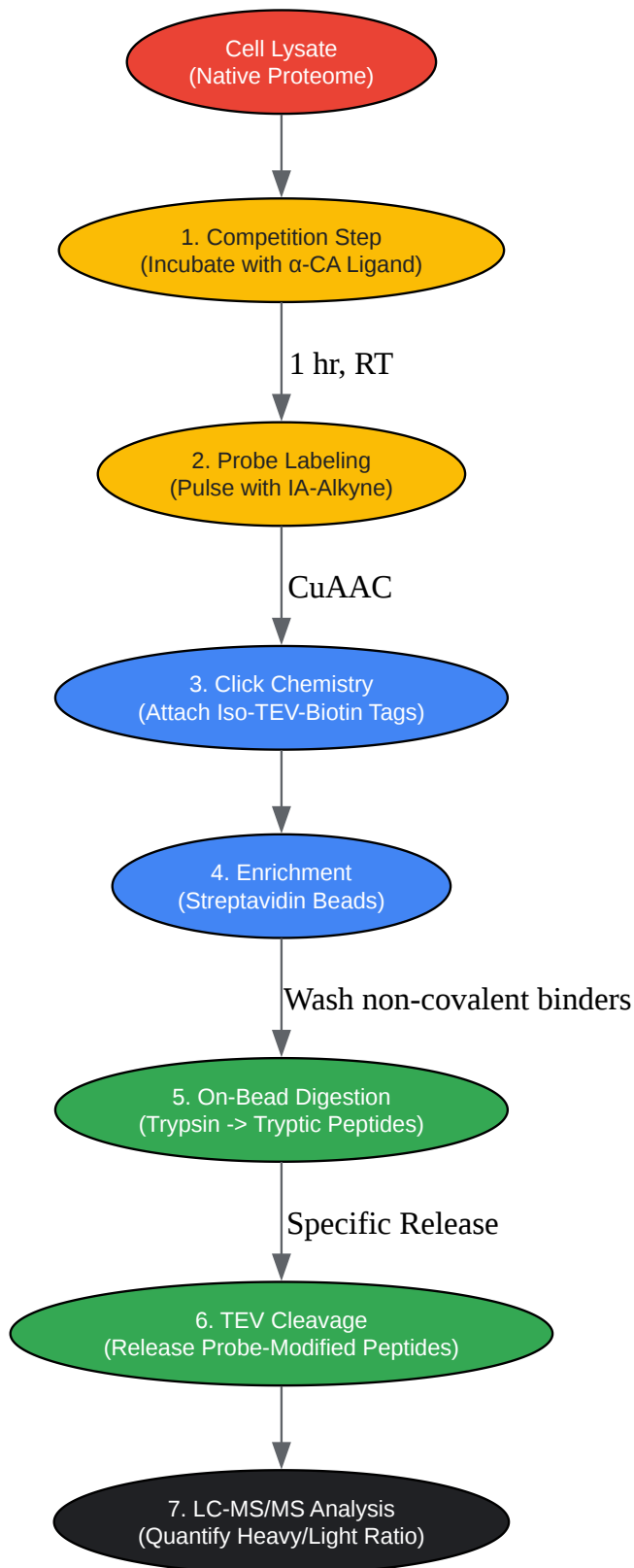

[Click to download full resolution via product page](#)

Figure 2: Competitive isoTOP-ABPP workflow for identifying targets of  $\alpha$ -chloroacetamide ligands.

## Step-by-Step Methodology

### Step 1: Proteome Preparation & Competition

- Lysis: Lyse cells (e.g., 10 mg protein total) in Lysis Buffer by sonication. Centrifuge (100,000 x g, 45 min) to separate soluble proteome.
- Normalization: Adjust protein concentration to 2 mg/mL.
- Competition: Split lysate into two aliquots:
  - Sample A (Light): Treat with DMSO (Vehicle).
  - Sample B (Heavy): Treat with  $\alpha$ -CA Ligand (e.g., 10-50  $\mu$ M).
- Incubation: Incubate for 60 minutes at Room Temperature (RT).

### Step 2: Probe Labeling (The "Pulse")

- Add IA-alkyne (100  $\mu$ M final) to both samples.
- Incubate for 1 hour at RT.
  - Note: Any cysteine blocked by your  $\alpha$ -CA ligand in Step 1 will not react with IA-alkyne.

### Step 3: Click Chemistry & Enrichment

- Cocktail Prep: Prepare Click mix:

TBTA,

TCEP,

,

Azide-TEV-Biotin (Light tag for Sample A, Heavy tag for Sample B).

- Reaction: Add Click mix to lysates. Vortex and incubate 1 hour at RT.

- Precipitation: Precipitate proteins with cold methanol/chloroform to remove excess reagents. Resuspend pellets in 6M Urea/PBS.
- Combine: Mix Sample A and Sample B (1:1 ratio).
- Enrichment: Incubate combined sample with Streptavidin-agarose beads (2 hours).

## Step 4: Digestion & Elution

- Wash: Extensively wash beads (PBS, SDS, Urea) to remove non-specific binders.
- Tryptic Digest: Resuspend beads in digestion buffer (2M Urea). Add Trypsin. Incubate overnight at 37°C.
  - Crucial: This digests the protein backbone but leaves the probe-labeled peptide attached to the bead via biotin.
- Wash Again: Wash away unmodified tryptic peptides.
- TEV Elution: Add TEV protease. Incubate overnight at 30°C.
  - Mechanism:<sup>[2]</sup><sup>[3]</sup><sup>[4]</sup> TEV cleaves the specific linker in the tag, releasing only the probe-labeled cysteine peptides into the supernatant.

## Step 5: Mass Spectrometry

- Acidify supernatant (Formic acid) and analyze via LC-MS/MS.
- Data Analysis: Calculate the Ratio ( ) of Heavy (Ligand treated) vs. Light (DMSO).
  - : No binding (Cysteine was available to IA-alkyne in both).
  - : Hit. The  $\alpha$ -CA ligand blocked IA-alkyne labeling in the Heavy sample.

## Troubleshooting & Optimization

Issue	Probable Cause	Corrective Action
Low Labeling Efficiency	pH < 7.0	Ensure buffer pH is 7.5–8.0. Cysteine reactivity is thiolate-dependent.
High Background/Precipitation	Probe insolubility	Dissolve $\alpha$ -CA probes in high-grade DMSO. Ensure final DMSO < 2%.
Methionine Oxidation	Reagent side-reactivity	While $\alpha$ -CA is more specific than IA, oxidation can occur. <sup>[2]</sup> Use fresh reagents and minimize light exposure.
No Competition Observed	Ligand inactivity or slow kinetics	$\alpha$ -CA is a "slow" warhead. Increase incubation time (up to 4 hours) or concentration.

## References

- Backus, K. M., et al. (2016).<sup>[5][6]</sup> Proteome-wide covalent ligand discovery in native biological systems.<sup>[5]</sup> *Nature*, 534(7608), 570–574.
- Weerapana, E., et al. (2010). Quantitative reactivity profiling predicts functional cysteines in proteomes. *Nature*, 468(7325), 790–795.
- Kuljanin, M., et al. (2021). Reimagining high-throughput profiling of reactive cysteines for cell-based screening of large electrophile libraries. *Nature Biotechnology*, 39, 630–641.
- Pace, N. J., & Weerapana, E. (2013). A competitive chemical-proteomic platform for identifying zinc-binding cysteines. *ACS Chemical Biology*, 8(2), 283–287.

### Need Custom Synthesis?

BenchChem offers custom synthesis for rare earth carbides and specific isotopic labeling.

Email: [info@benchchem.com](mailto:info@benchchem.com) or [Request Quote Online](#).

## Sources

- [1. vividion.com \[vividion.com\]](https://www.vividion.com)
- [2. pdf.benchchem.com \[pdf.benchchem.com\]](https://pdf.benchchem.com)
- [3. US20170233788A1 - Cysteine Labelling - Google Patents \[patents.google.com\]](https://patents.google.com)
- [4. Cysteine alkylation methods in shotgun proteomics and their possible effects on methionine residues - PubMed \[pubmed.ncbi.nlm.nih.gov\]](https://pubmed.ncbi.nlm.nih.gov)
- [5. researchgate.net \[researchgate.net\]](https://www.researchgate.net)
- [6. Practical Fragments: Covalent fragments writ large \[practicalfragments.blogspot.com\]](https://practicalfragments.blogspot.com)
- To cite this document: BenchChem. [Application Note: Cysteine Labeling with Alpha-Chloroacetamide Probes]. BenchChem, [2026]. [Online PDF]. Available at: [\[https://www.benchchem.com/product/b3382922/docs#application-note-cysteine-labeling-with-alpha-chloroacetamide-probes\]](https://www.benchchem.com/product/b3382922/docs#application-note-cysteine-labeling-with-alpha-chloroacetamide-probes)

---

### Disclaimer & Data Validity:

The information provided in this document is for Research Use Only (RUO) and is strictly not intended for diagnostic or therapeutic procedures. While BenchChem strives to provide accurate protocols, we make no warranties, express or implied, regarding the fitness of this product for every specific experimental setup.

**Technical Support:** The protocols provided are for reference purposes. Unsure if this reagent suits your experiment?

**Need Industrial/Bulk Grade?** [Request Custom Synthesis Quote](#)

## BenchChem

Our mission is to be the trusted global source of essential and advanced chemicals, empowering scientists and researchers to drive progress in science and industry.

### Contact

Address: 3281 E Guasti Rd

Ontario, CA 91761, United States

Phone: (601) 213-4426

Email: [info@benchchem.com](mailto:info@benchchem.com)

Contact our Ph.D. Support Team for a compatibility check