

# The 4-Bromobenzyl Group: A Multifunctional Modulator in Molecular Design

**Author:** BenchChem Technical Support Team. **Date:** March 2026

## Compound of Interest

Compound Name: 4-Bromobenzyl 2-furoate

Cat. No.: B338773

[Get Quote](#)

An In-depth Technical Guide for Researchers, Scientists, and Drug Development Professionals

## Introduction: Beyond a Simple Substituent

In the vast lexicon of chemical functionalities, the 4-bromobenzyl group stands out for its remarkable versatility. It is far more than a simple aromatic scaffold; it is a finely tunable instrument for modulating molecular interactions, directing reactivity, and imparting specific physicochemical properties. This guide provides a comprehensive exploration of the 4-bromobenzyl moiety, moving from its fundamental characteristics to its sophisticated applications in supramolecular chemistry, organic synthesis, and medicinal chemistry. We will delve into the causality behind its utility, offering not just protocols but the strategic reasoning that empowers researchers to leverage this group to its full potential. The narrative is built upon a foundation of established chemical principles and supported by authoritative references, ensuring a trustworthy and expert-driven resource for professionals in the field.

## Section 1: Core Physicochemical Properties and Their Implications

The utility of the 4-bromobenzyl group stems from a unique interplay of electronic, steric, and reactive characteristics originating from its two key components: the benzyl framework and the para-bromo substituent.

### Electronic Effects: A Delicate Balance

The bromine atom at the para-position exerts two opposing electronic effects on the benzene ring:

- Inductive Effect (-I): As an electronegative halogen, bromine withdraws electron density from the aromatic ring through the sigma bond framework. This effect is distance-dependent and deactivates the ring towards electrophilic substitution.
- Resonance Effect (+R): The lone pairs on the bromine atom can be delocalized into the  $\pi$ -system of the benzene ring, donating electron density.

Overall, the inductive effect slightly outweighs the resonance effect, making the bromine a weak deactivator. However, this nuanced electronic profile is critical. It subtly modulates the electron density of the entire moiety, influencing its participation in non-covalent interactions without drastically altering the fundamental chemistry of the benzyl group.

## Reactivity Profile: Dual Functional Handles

The 4-bromobenzyl group offers two distinct sites for chemical modification, a property that makes it an invaluable building block in multi-step synthesis.

- The Benzylic Position: The carbon atom adjacent to the aromatic ring is highly reactive. In derivatives like 4-bromobenzyl bromide, this position is exceptionally electrophilic and susceptible to nucleophilic substitution ( $S_N2$ ) reactions.<sup>[1]</sup> This reactivity is the basis for its use as a protecting group and for introducing the entire moiety into a target molecule.
- The Aromatic C-Br Bond: The bond between the bromine atom and the aromatic ring is a robust handle for modern cross-coupling reactions. It readily participates in transformations like Suzuki, Heck, and Sonogashira couplings, allowing for the formation of C-C, C-N, and C-O bonds. This provides a secondary, orthogonal site for molecular elaboration.

This dual reactivity allows for a programmed, sequential functionalization strategy, which is a cornerstone of complex molecule synthesis.

## Supramolecular Interactions: The Power of Halogen Bonding

Perhaps the most significant role of the 4-bromobenzyl group in modern molecular science is its ability to participate in halogen bonding. Due to the electron-withdrawing nature of the C-Br bond, the electron density around the bromine atom is anisotropically distributed. This creates a region of positive electrostatic potential, known as a  $\sigma$ -hole, on the outermost portion of the bromine atom, along the C-Br bond axis.<sup>[2]</sup> This  $\sigma$ -hole can interact favorably with electron-rich atoms (e.g., oxygen, nitrogen, sulfur), forming a highly directional and specific non-covalent bond.<sup>[2][3]</sup>

The strength and geometry of these halogen bonds have a profound effect on crystal packing and molecular recognition.<sup>[4][5]</sup> Studies have shown that the interactions of the bromine substituent have an explicit and predictable effect on the crystal packing of molecules.<sup>[4][6]</sup>

## Section 2: Applications in Supramolecular Chemistry and Crystal Engineering

The predictable, directional nature of the interactions involving the 4-bromobenzyl group makes it a powerful tool for crystal engineering—the rational design of crystalline solids with desired properties.<sup>[5]</sup>

### Directing Crystal Packing

The 4-bromobenzyl group can orchestrate molecular assembly in the solid state through a combination of non-covalent forces:

- Halogen Bonds (Br $\cdots$ X): As discussed, these are the primary directional interactions. The C–Br $\cdots$ X angle is typically close to linear (180°), providing a high degree of predictability.<sup>[5][7]</sup>
- $\pi$ - $\pi$  Stacking: The electron-rich aromatic ring readily engages in stacking interactions with adjacent rings.
- C-H $\cdots$  $\pi$  Interactions: The hydrogen atoms on the benzyl group or neighboring molecules can interact with the face of the aromatic ring.<sup>[8]</sup>
- Halogen-Halogen Interactions (Br $\cdots$ Br): These interactions, while often weaker, can also contribute to the overall crystal lattice energy and influence packing motifs.<sup>[4][9]</sup> Their nature is complex, dominated by dispersion but with a significant electrostatic component.<sup>[9]</sup>

The interplay of these forces allows for the construction of specific supramolecular architectures, such as chains, sheets, or complex 3D networks.[10]

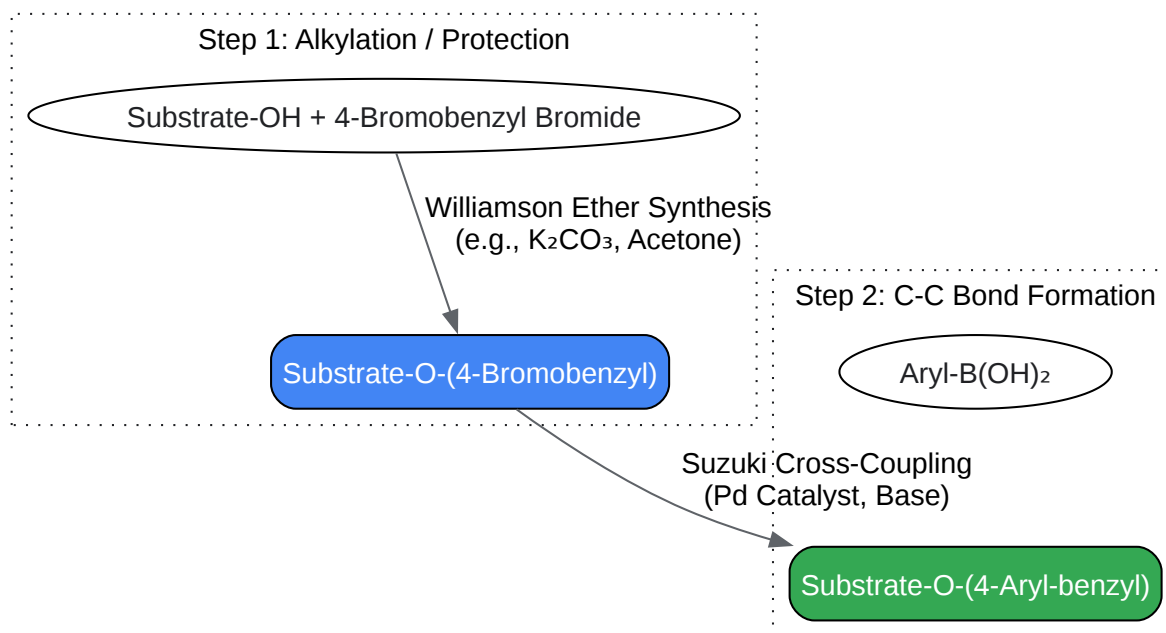
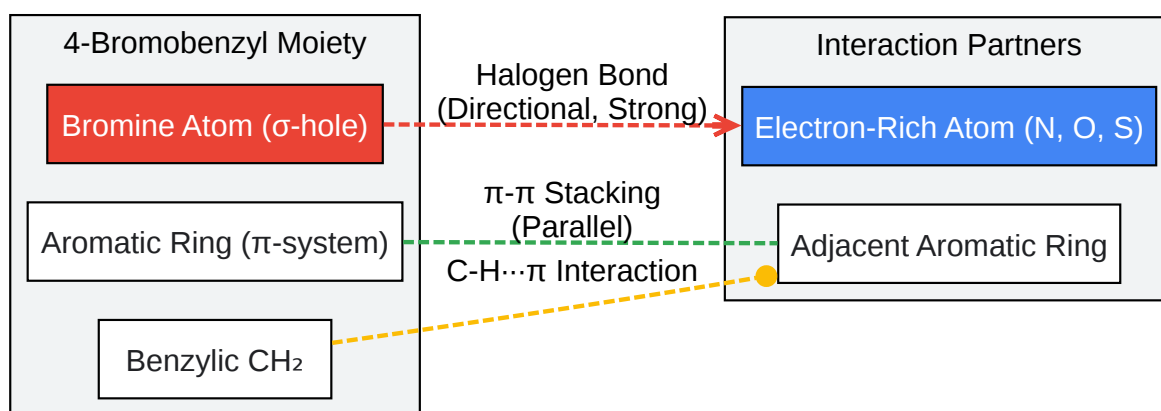

[Click to download full resolution via product page](#)

Caption: Orthogonal reactivity of the 4-bromobenzyl group in synthesis.

## Experimental Protocol: Williamson Ether Synthesis

This protocol describes the protection of a phenolic hydroxyl group using 4-bromobenzyl bromide, a foundational reaction in multi-step synthesis. [11] Objective: To synthesize 5-Bromo-2-[(4-bromobenzyl)oxy]benzaldehyde. [11] Materials:

- 5-Bromo-2-hydroxybenzaldehyde
- 4-Bromobenzyl bromide
- Potassium carbonate ( $K_2CO_3$ ), anhydrous
- Acetone, anhydrous
- Standard workup and purification reagents (Dichloromethane, water, brine, anhydrous magnesium sulfate)

### Procedure:

- Setup: To a round-bottom flask equipped with a magnetic stirrer and reflux condenser, add 5-bromo-2-hydroxybenzaldehyde (1.0 eq), anhydrous potassium carbonate (1.5 eq), and anhydrous acetone to form a stirrable suspension.
  - Causality: Potassium carbonate is a mild, inexpensive base sufficient to deprotonate the phenol to its more nucleophilic phenoxide form. Acetone is a suitable polar aprotic solvent for this  $S_N2$  reaction.
- Addition: Add 4-bromobenzyl bromide (1.1 eq) to the suspension.
  - Causality: A slight excess of the alkylating agent ensures complete consumption of the starting phenol.
- Reaction: Heat the mixture to reflux and maintain for 4-6 hours, monitoring the reaction progress by Thin Layer Chromatography (TLC).
- Workup: After cooling to room temperature, filter off the solid potassium salts and wash with acetone. Concentrate the filtrate under reduced pressure.

- Extraction: Dissolve the residue in dichloromethane and wash sequentially with water and brine. Dry the organic layer over anhydrous magnesium sulfate.
  - Causality: The aqueous washes remove any remaining inorganic salts and water-soluble impurities.
- Purification: Filter off the drying agent and concentrate the solvent. Purify the crude product by column chromatography on silica gel or recrystallization to yield the pure ether.

Self-Validation: The success of the reaction is confirmed by spectroscopic analysis ( $^1\text{H}$  NMR,  $^{13}\text{C}$  NMR, MS) showing the disappearance of the phenolic -OH proton signal and the appearance of characteristic benzylic -CH<sub>2</sub>- protons and signals corresponding to the 4-bromobenzyl group.

## Section 4: A Strategic Element in Medicinal Chemistry

In drug design, the introduction of a bromine atom is a well-established strategy to modulate a compound's biological profile. [2]The 4-bromobenzyl group is particularly effective as it combines the steric bulk and hydrophobic character of the benzyl group with the unique properties of bromine.

### Enhancing Target Affinity and Selectivity

The ability of the bromine atom to act as a halogen bond donor is a key tool for enhancing protein-ligand interactions. [2]

- Specific Interactions: A strategically placed 4-bromobenzyl group can form a halogen bond with a backbone carbonyl oxygen or an electron-rich side chain (e.g., Ser, Thr, Asp, Glu) in a receptor's binding pocket. This adds a specific, directional interaction that can significantly increase binding affinity.
- Case Study - Topoisomerase Inhibitors: In the design of anticancer agents, a 2-(4-bromobenzyl) moiety was incorporated into a thienopyrimidine scaffold. [12]Docking studies revealed that the bromophenyl group formed a crucial halogen bond with a histidine residue (HIE130) in the active site of Topoisomerase II, contributing to the compound's potent

inhibitory activity. [12]The aromatic ring also participated in favorable  $\pi$ - $\pi$  stacking interactions. [12]

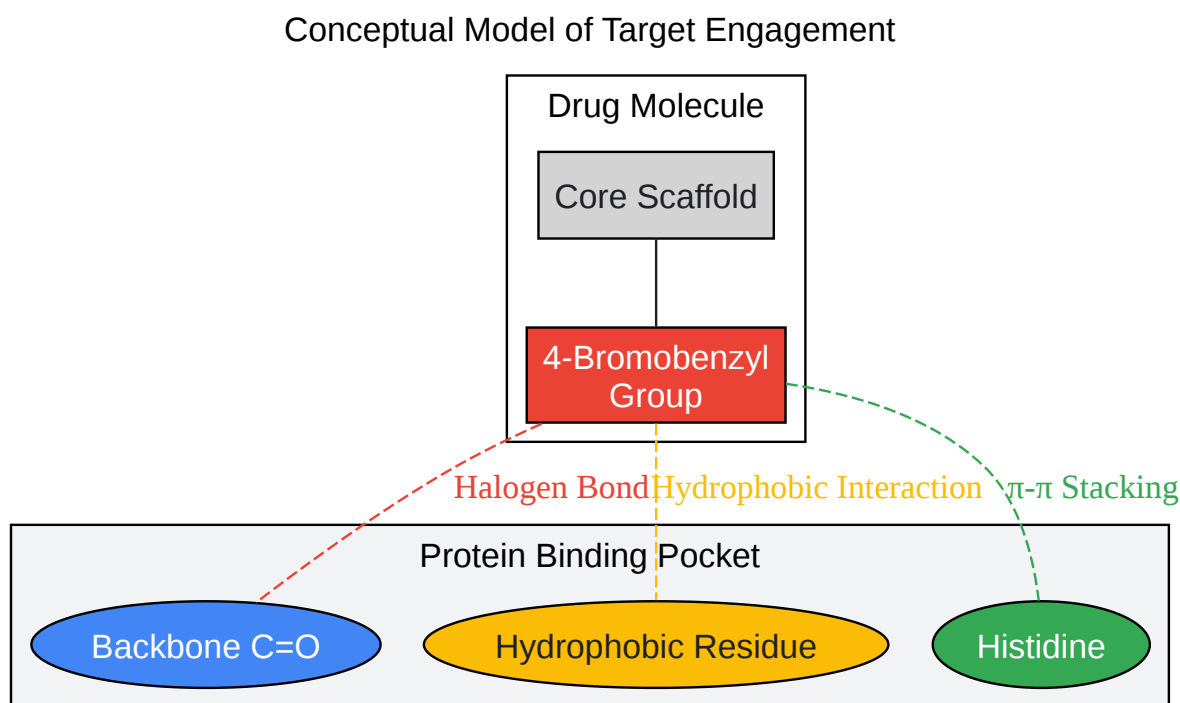

[Click to download full resolution via product page](#)

Caption: Multimodal interactions of a 4-bromobenzyl group in a protein active site.

## Modulating Pharmacokinetic Properties

The introduction of a 4-bromobenzyl group can have a significant impact on a drug candidate's Absorption, Distribution, Metabolism, and Excretion (ADME) profile.

- **Lipophilicity:** Bromine is a lipophilic atom. Its inclusion generally increases the overall lipophilicity (LogP) of a molecule, which can enhance membrane permeability and absorption.
- **Metabolic Stability:** The C(aryl)-Br bond is very stable to metabolic cleavage. Placing it at a position susceptible to oxidative metabolism (e.g., by Cytochrome P450 enzymes) can block that metabolic pathway, thereby increasing the drug's half-life.

- Case Study - Endothelin Receptor Antagonists: In the development of the dual endothelin receptor antagonist Macitentan, structure-activity relationship (SAR) studies showed that introducing a bromine atom at the para-position of a key phenyl ring significantly improved the compound's affinity for both the ET\_A and ET\_B receptors compared to the unsubstituted analog. [13] This highlights the favorable impact of this substitution on target engagement.

## Conclusion

The 4-bromobenzyl group is a powerful and multifaceted tool in the hands of chemists and drug designers. Its well-defined physicochemical properties—a balance of electronic effects, dual-mode reactivity, and a capacity for specific, directional halogen bonding—make it an exemplary functional group for the rational design of molecules. From orchestrating solid-state architectures through crystal engineering to serving as a robust protecting group and a key pharmacophore element that enhances drug-target interactions, the 4-bromobenzyl moiety provides a reliable and predictable means to control molecular behavior. A thorough understanding of its roles, as detailed in this guide, is essential for any scientist seeking to innovate in the synthesis and application of complex organic molecules.

## References

- Synthesis of 4-bromobenzyl methyl ether. PrepChem.com. Available at: [\[Link\]](#)
- Rankin, G. M., Maxwell-Cameron, I., Painter, G. F., & Larsen, D. S. (2013). An Alternative to the p-Methoxybenzyl Group for Protection of Carbohydrates. The Journal of Organic Chemistry. Available at: [\[Link\]](#)
- 4-Bromobenzyl Group As a Linker for Chemical Probes. J-GLOBAL. Available at: [\[Link\]](#)
- The effect of halogen bonding on the packing of bromine-substituted pyridine and benzyl functionalized resorcinarene tetrapodands in the solid state. CrystEngComm (RSC Publishing). Available at: [\[Link\]](#)
- Isostructural Halogen Exchange and Halogen Bonds: The Case of N-(4-Halogenobenzyl)-3-halogenopyridinium Halogenides. PMC. Available at: [\[Link\]](#)

- Synthesis, crystal structure, Hirshfeld surface analysis, density function theory calculations and photophysical properties of methyl 4'-[(4-bromobenzoyl)oxy]biphenyl-4-carboxylate: a compound with bromine...oxygen contacts. PMC. Available at: [\[Link\]](#)
- Benzyl group. Wikipedia. Available at: [\[Link\]](#)
- 4-Bromobenzyl bromide | CAS 589-15-1. Catsyn. Available at: [\[Link\]](#)
- Isostructural Halogen Exchange and Halogen Bonds: The Case of N-(4-Halogenobenzyl)-3-halogenopyridinium Halogenides. Crystal Growth & Design. Available at: [\[Link\]](#)
- Prediction of Crystal Structures and Mechanical Properties for Brittle, Plastic, and Elastic Polymorphs of 4-Bromophenyl 4-Bromobenzoate. ACS Publications. Available at: [\[Link\]](#)
- Synthesis, crystal structure and Hirshfeld surface analysis of the orthorhombic polymorph of 4-bromo-N-(4-bromobenzylidene)aniline. PMC. Available at: [\[Link\]](#)
- 4-Bromobenzyl alcohol | C7H7BrO | CID 70119. PubChem. Available at: [\[Link\]](#)
- Miller, M. T., Gantzel, P. K., & Karpishin, T. B. (1999). Effects of Sterics and Electronic Delocalization on the Photophysical, Structural, and Electrochemical Properties of 2,9-Disubstituted 1,10-Phenanthroline Copper(I) Complexes. Inorganic Chemistry. Available at: [\[Link\]](#)
- The Discovery of N-[5-(4-Bromophenyl)-6-[2-[(5-bromo-2-pyrimidinyl)oxy]ethoxy]-4-pyrimidinyl]-N'-propylsulfamide (Macitentan), an Orally Active, Potent Dual Endothelin Receptor Antagonist. Journal of Medicinal Chemistry. Available at: [\[Link\]](#)
- The effect of halogen bonding on the packing of bromine-substituted pyridine and benzyl functionalized resorcinarene tetrapodands in the solid state. ResearchGate. Available at: [\[Link\]](#)
- Protecting Groups. University of Bristol. Available at: [\[Link\]](#)
- 2-(4-Bromobenzyl) tethered 4-amino aryl/alkyl-5,6,7,8-tetrahydrobenzo[1,4]hieno[2,3-d]pyrimidines: design, synthesis, anticancer assessment via dual topoisomerase-I/II inhibition, and in silico studies. PMC. Available at: [\[Link\]](#)

- 4-Bromobenzyl bromide | C7H6Br2 | CID 68527. PubChem. Available at: [\[Link\]](#)
- One Dimensional Halogen Bond Design: Br...N versus I. RSC Publishing. Available at: [\[Link\]](#)
- Protecting Groups List. SynArchive. Available at: [\[Link\]](#)
- Crystal structure, absolute configuration, and phosphodiesterase inhibitory activity of (+)-1-(4-bromobenzyl)-4-[(3-cyclopentyloxy)-4-methoxyphenyl]-2-pyrrolidinone. Journal of Medicinal Chemistry. Available at: [\[Link\]](#)
- Stereoelectronic Effect of Protecting Groups on the Stability of Galactosyl Donor Intermediates. MDPI. Available at: [\[Link\]](#)
- Introducing bromine to the molecular structure as a strategy for drug design. Naunyn-Schmiedeberg's Archives of Pharmacology. Available at: [\[Link\]](#)
- The crystal structure of 6-(4-bromobenzyl)-1,3,5-trimethyl-7-phenyl-1,5-dihydro-2H-pyrrolo[3,2-d]pyrimidine-2,4(3H)-dione, C22H20BrN3O2. ResearchGate. Available at: [\[Link\]](#)
- The nature of the C–Br...Br–C intermolecular interactions found in molecular crystals: a general theoretical-database study. CrystEngComm (RSC Publishing). Available at: [\[Link\]](#)

### Need Custom Synthesis?

BenchChem offers custom synthesis for rare earth carbides and specific isotopic labeling.

Email: [info@benchchem.com](mailto:info@benchchem.com) or [Request Quote Online](#).

## Sources

- 1. [chemimpex.com](http://chemimpex.com) [[chemimpex.com](http://chemimpex.com)]
- 2. Introducing bromine to the molecular structure as a strategy for drug design | Journal of Medical Science [[jms.ump.edu.pl](http://jms.ump.edu.pl)]
- 3. [pubs.rsc.org](http://pubs.rsc.org) [[pubs.rsc.org](http://pubs.rsc.org)]
- 4. The effect of halogen bonding on the packing of bromine-substituted pyridine and benzyl functionalized resorcinarene tetrapodands in the solid state - CrystEngComm (RSC Publishing) [[pubs.rsc.org](http://pubs.rsc.org)]

- [5. Isostructural Halogen Exchange and Halogen Bonds: The Case of N-\(4-Halogenobenzyl\)-3-halogenopyridinium Halogenides - PMC \[pmc.ncbi.nlm.nih.gov\]](#)
- [6. researchgate.net \[researchgate.net\]](#)
- [7. pubs.acs.org \[pubs.acs.org\]](#)
- [8. Synthesis, crystal structure and Hirshfeld surface analysis of the orthorhombic polymorph of 4-bromo-N-\(4-bromobenzylidene\)aniline - PMC \[pmc.ncbi.nlm.nih.gov\]](#)
- [9. The nature of the C–Br⋯Br–C intermolecular interactions found in molecular crystals: a general theoretical-database study - CrystEngComm \(RSC Publishing\) \[pubs.rsc.org\]](#)
- [10. Synthesis, crystal structure, Hirshfeld surface analysis, density function theory calculations and photophysical properties of methyl 4'-\[\(4-bromobenzoyl\)oxy\]biphenyl-4-carboxylate: a compound with bromine⋯oxygen contacts - PMC \[pmc.ncbi.nlm.nih.gov\]](#)
- [11. pdf.benchchem.com \[pdf.benchchem.com\]](#)
- [12. 2-\(4-Bromobenzyl\) tethered 4-amino aryl/alkyl-5,6,7,8-tetrahydrobenzo\[4,5\]thieno\[2,3-d\]pyrimidines: design, synthesis, anticancer assessment via dual topoisomerase-I/II inhibition, and in silico studies - PMC \[pmc.ncbi.nlm.nih.gov\]](#)
- [13. pubs.acs.org \[pubs.acs.org\]](#)
- [14. pdf.benchchem.com \[pdf.benchchem.com\]](#)
- To cite this document: BenchChem. [The 4-Bromobenzyl Group: A Multifunctional Modulator in Molecular Design]. BenchChem, [2026]. [Online PDF]. Available at: [<https://www.benchchem.com/product/b338773#role-of-the-4-bromobenzyl-group-in-molecular-interactions>]

---

### Disclaimer & Data Validity:

The information provided in this document is for Research Use Only (RUO) and is strictly not intended for diagnostic or therapeutic procedures. While BenchChem strives to provide accurate protocols, we make no warranties, express or implied, regarding the fitness of this product for every specific experimental setup.

**Technical Support:** The protocols provided are for reference purposes. Unsure if this reagent suits your experiment? [[Contact our Ph.D. Support Team for a compatibility check](#)]

**Need Industrial/Bulk Grade?** [Request Custom Synthesis Quote](#)

# BenchChem

Our mission is to be the trusted global source of essential and advanced chemicals, empowering scientists and researchers to drive progress in science and industry.

## Contact

Address: 3281 E Guasti Rd

Ontario, CA 91761, United States

Phone: (601) 213-4426

Email: [info@benchchem.com](mailto:info@benchchem.com)