

# Physical properties of functionalized benzyl naphthoates

**Author:** BenchChem Technical Support Team. **Date:** March 2026

## Compound of Interest

Compound Name: 4-(Ethoxycarbonyl)benzyl 1-naphthoate

Cat. No.: B338839

[Get Quote](#)

An In-depth Technical Guide to the Physical Properties of Functionalized Benzyl Naphthoates

## Introduction

Functionalized benzyl naphthoates are a class of aromatic esters holding significant promise in medicinal chemistry and materials science. As precursors and core scaffolds for novel therapeutics, understanding their physicochemical properties is paramount for researchers, scientists, and drug development professionals.[1] The strategic placement of functional groups on the benzyl and naphthyl rings allows for the fine-tuning of molecular characteristics, directly influencing factors such as solubility, crystal packing, and interaction with biological targets.[2] This guide provides a comprehensive exploration of the key physical properties of these compounds, detailing the theoretical underpinnings, practical experimental protocols for their determination, and the expected impact of various functionalizations.

## Molecular Structure: The Foundation of Physical Properties

The fundamental structure of a benzyl naphthoate consists of a naphthyl group linked to a benzyl group via an ester functional group (-COO-). The physical properties of these molecules are not dictated by the core structure alone but are profoundly influenced by the nature and position of substituents on both aromatic rings.

Key structural factors influencing physical properties include:

- **Polarity:** The ester group itself is polar, but the large, nonpolar naphthalene and benzene rings dominate the overall character, making the parent compounds generally nonpolar.[3] The addition of polar functional groups (e.g., -OH, -NH<sub>2</sub>, -NO<sub>2</sub>) or nonpolar groups (e.g., -CH<sub>3</sub>, -tBu) can significantly alter the molecule's overall dipole moment.
- **Intermolecular Forces:** Van der Waals forces are the primary intermolecular interaction in unsubstituted benzyl naphthoates. Functional groups can introduce stronger forces such as dipole-dipole interactions or hydrogen bonding (if groups like -OH or -COOH are present), which dramatically affects melting and boiling points.[4]
- **Molecular Symmetry and Packing:** The ability of molecules to pack efficiently into a crystal lattice influences the melting point.[5] Symmetrical molecules often have higher melting points. The size and shape of functional groups can either enhance or disrupt this packing.
- **$\pi$ - $\pi$  Stacking:** The presence of two extended aromatic systems (naphthalene and benzene rings) allows for potential  $\pi$ - $\pi$  stacking interactions, contributing to the stability of the solid state.[5]

Below is a diagram illustrating the general structure and potential sites for functionalization.

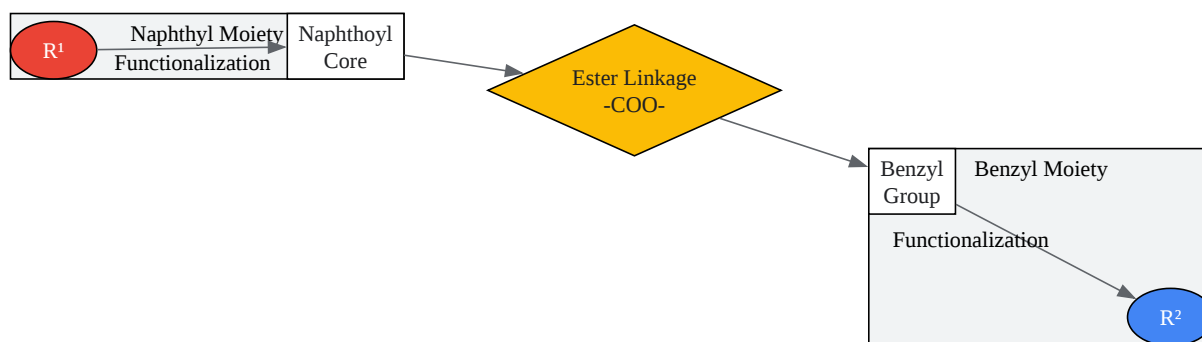

General Structure of a Functionalized Benzyl Naphthoate

[Click to download full resolution via product page](#)

Caption: General structure showing functionalization points ( $R^1$ ,  $R^2$ ) on the naphthyl and benzyl moieties.

## Synthesis Pathway: A General Overview

The most common method for synthesizing benzyl naphthoates is the Fischer esterification, involving the reaction of a naphthoic acid derivative with a benzyl alcohol derivative in the presence of an acid catalyst.[6] This versatile method allows for the introduction of a wide array of functional groups on either starting material.

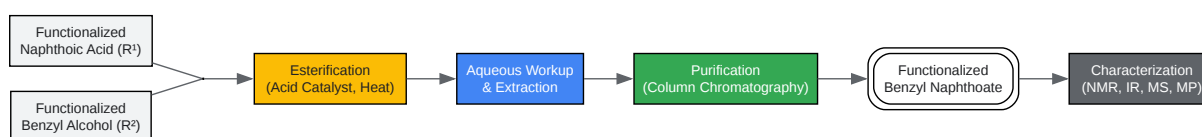

[Click to download full resolution via product page](#)

Caption: General workflow for the synthesis and purification of functionalized benzyl naphthoates.

## Core Physical Properties and Characterization Protocols

### Melting Point (MP)

The melting point is a critical physical property that provides a primary indication of a compound's purity and identity.[7] Pure crystalline solids typically exhibit a sharp melting range of 0.5-1.0 °C.[4] Impurities will generally cause a depression and broadening of the melting range.[8]

Causality Behind Experimental Choices: The choice of a slow heating rate (1-2 °C/minute) near the expected melting point is crucial.[7] A rapid heating rate does not allow for thermal equilibrium between the sample, the thermometer, and the heating block, leading to an inaccurately high and broad melting range.[7] Packing the sample tightly ensures uniform heat transfer throughout the solid.[4]

## Experimental Protocol: Capillary Melting Point Determination

- **Sample Preparation:** Place a small amount of the dry benzyl naphthoate sample on a clean, dry surface. Finely powder the sample with a spatula.[9]
- **Loading the Capillary:** Tap the open end of a capillary tube into the powdered sample to collect a small amount of material. Invert the tube and tap the sealed end gently on a hard surface to pack the sample into the bottom. Repeat until a sample height of 1-2 mm is achieved.[7][10]
- **Apparatus Setup:** Place the loaded capillary tube into the sample holder of a digital melting point apparatus (e.g., a DigiMelt).[8]
- **Rapid Determination (Optional):** If the approximate MP is unknown, perform a rapid run by setting a fast temperature ramp (e.g., 10-20 °C/minute) to find a preliminary range.[8]
- **Accurate Determination:** For an accurate measurement, set the starting temperature to ~20 °C below the expected or preliminary MP. Set the ramp rate to 1-2 °C/minute.[10]
- **Recording the Range:** Record the temperature at which the first drop of liquid appears (T1) and the temperature at which the last solid crystal melts (T2). The melting point is reported as the range T1 - T2.[7]
- **Verification:** Repeat the measurement with a fresh sample and capillary to ensure reproducibility.[9]

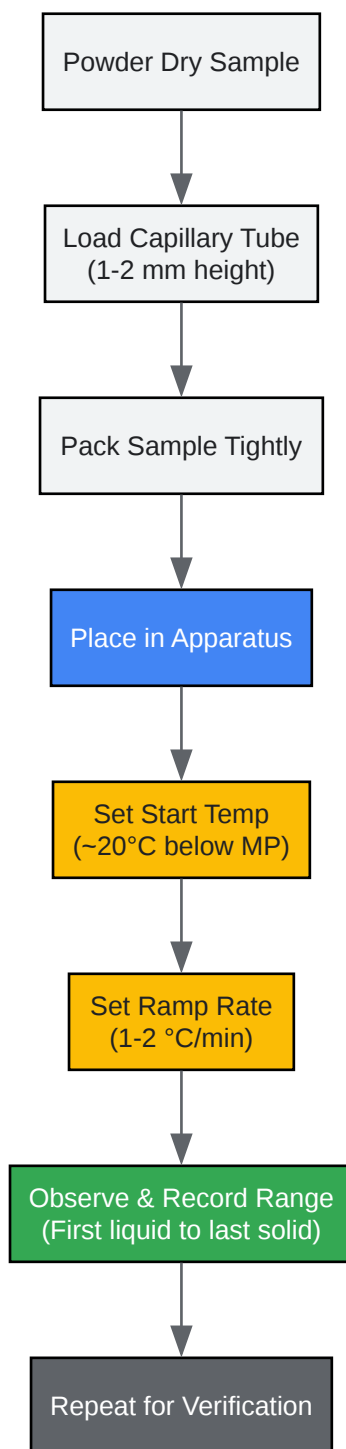

[Click to download full resolution via product page](#)

Caption: Step-by-step workflow for accurate melting point determination.

## Solubility

The solubility of a benzyl naphthoate derivative is governed by the principle of "like dissolves like." The large aromatic framework makes them inherently soluble in common organic solvents and generally insoluble in water.<sup>[11][12]</sup> Functionalization can be used to modulate solubility for specific applications, such as formulation for biological assays.

Expected Solubility Trends:

Functional Group Type	Example Groups	Expected Solubility in Nonpolar Solvents (e.g., Hexane, Toluene)	Expected Solubility in Polar Aprotic Solvents (e.g., Acetone, THF)	Expected Solubility in Polar Protic Solvents (e.g., Ethanol, Methanol)
Nonpolar/Weakly Polar	-H, -CH <sub>3</sub> , -Cl, -Br	High	High	Moderate
Moderately Polar	-OCH <sub>3</sub> , -COOCH <sub>3</sub>	Moderate	High	Moderate-High
Polar/Hydrogen Bonding	-NO <sub>2</sub> , -CN	Low-Moderate	High	Moderate
Highly Polar/Ionic	-OH, -COOH, -NH <sub>2</sub>	Very Low	Moderate-High	Moderate (H-bonding)

#### Experimental Protocol: Qualitative Solubility Testing

- Preparation: Add approximately 10 mg of the compound to a small test tube.
- Solvent Addition: Add the chosen solvent (e.g., water, ethanol, toluene, acetone) dropwise, starting with 0.5 mL.
- Mixing: Agitate the mixture vigorously (e.g., using a vortex mixer) for 1-2 minutes.
- Observation: Visually inspect the solution. Classify as:
  - Soluble: A clear, homogeneous solution is formed.

- Partially Soluble: Some solid dissolves, but undissolved particles remain.
- Insoluble: The solid does not appear to dissolve.
- Documentation: Record the results for a range of solvents with varying polarities.[13]

## Spectroscopic and Chromatographic Properties

Spectroscopic and chromatographic methods are indispensable for confirming the identity, structure, and purity of synthesized benzyl naphthoates.[14]

1. Nuclear Magnetic Resonance (NMR) Spectroscopy: Provides detailed information about the carbon-hydrogen framework.[15]

- $^1\text{H}$  NMR: Expect signals for aromatic protons in the  $\delta$  7.0-8.5 ppm range. The benzylic protons (-CH<sub>2</sub>-) typically appear as a singlet around  $\delta$  5.0-5.5 ppm. Protons of functional groups will have characteristic shifts.
- $^{13}\text{C}$  NMR: The ester carbonyl carbon is a key diagnostic peak, appearing around  $\delta$  165-175 ppm. Aromatic carbons resonate in the  $\delta$  120-150 ppm region.

2. Infrared (IR) Spectroscopy: Used to identify key functional groups.[16]

- The most prominent and characteristic peak will be the strong C=O (ester) stretch, typically found between 1715-1735 cm<sup>-1</sup>.
- Aromatic C=C stretches appear in the 1450-1600 cm<sup>-1</sup> region.
- C-O stretches are visible in the 1100-1300 cm<sup>-1</sup> range.

3. High-Performance Liquid Chromatography (HPLC): The primary technique for assessing purity and for quantification.[17]

- Methodology: Reversed-phase HPLC is typically used, where the stationary phase is nonpolar (e.g., C18) and the mobile phase is a polar solvent mixture (e.g., acetonitrile/water or methanol/water).
- Elution: Less polar compounds will be retained longer on the column and thus have longer retention times. The introduction of polar functional groups will decrease the retention time.

Summary of Expected Characterization Data

Technique	Feature	Expected Range/Value	Influence of Functional Groups
<sup>1</sup> H NMR	Benzylic Protons (Ar-CH <sub>2</sub> -O)	δ 5.0 - 5.5 ppm	Electron-withdrawing groups on the benzyl ring may shift this downfield.
Aromatic Protons	δ 7.0 - 8.5 ppm	Substituent effects will alter the chemical shifts and splitting patterns.	
<sup>13</sup> C NMR	Ester Carbonyl (C=O)	δ 165 - 175 ppm	Relatively insensitive to distant functional groups.
IR	Ester Carbonyl Stretch	1715 - 1735 cm <sup>-1</sup>	Conjugation with the naphthyl ring places it in this range. Substituent effects are minor.
HPLC	Retention Time (Reversed-Phase)	Varies with conditions	Polar groups (-OH, -NO <sub>2</sub> ) decrease retention time; Nonpolar groups (-alkyl) increase it.

## Conclusion

The physical properties of functionalized benzyl naphthoates are a direct consequence of their molecular structure. By understanding the interplay between the core scaffold and the electronic and steric effects of various functional groups, researchers can predict and control properties such as melting point and solubility. The experimental protocols outlined in this guide provide a robust framework for the accurate characterization and purity assessment of these valuable compounds, facilitating their application in drug discovery and materials science.

Rigorous and reproducible characterization is the cornerstone of scientific integrity and is essential for advancing the development of novel chemical entities.

## References

- The University of Texas at Austin. Methodologies for the synthesis of functionalized naphthols and progress toward the total synthesis of vineomycinone B<sub>2</sub> methyl ester and actinophyllic acid. Available at: [\[Link\]](#).
- PMC - NIH. Synthesis of benzyl substituted naphthalenes from benzylidene tetralones. Available at: [\[Link\]](#).
- Introductory Chemistry. Functional Groups Names, Properties, and Reactions. Available at: [\[Link\]](#).
- EPA. 1-Benzyl-2-(benzyloxy)naphthalene Properties. Available at: [\[Link\]](#).
- MDPI. Assessment of the Thermal Properties of Aromatic Esters as Novel Phase Change Materials. Available at: [\[Link\]](#).
- ResearchGate. Synthesis of the N-benzyl derivative 6. Available at: [\[Link\]](#).
- GeeksforGeeks. Ester - Structure, Properties, Uses. Available at: [\[Link\]](#).
- Impact of Functional Groups in Organic Chemistry on Pharmaceutical Development. (2024). Available at: [\[Link\]](#).
- Experiment-1 Aim - To determine the melting point of given solid substance. Requirements. Available at: [\[Link\]](#).
- Experiment 1 - Melting Points. Available at: [\[Link\]](#).
- YouTube. Esters 2. Physical Properties. (2015). Available at: [\[Link\]](#).
- experiment (1) determination of melting points. (2021). Available at: [\[Link\]](#).
- ChemBK. BENZYL-2-NAPHTHYLEETHER. Available at: [\[Link\]](#).

- Organic Chemistry Frontiers (RSC Publishing). Synthesis of sulfonated naphthols via C–H bond functionalization with the insertion of sulfur dioxide. Available at: [\[Link\]](#).
- experiment #1 – Melting point. Available at: [\[Link\]](#).
- PubMed. Synthesis of Polysubstituted Naphthalenes by a Hydride Shift Mediated C-H Bond Functionalization/Aromatization Sequence. (2024). Available at: [\[Link\]](#).
- Truman ChemLab. Melting Point Experiment. Available at: [\[Link\]](#).
- PMC. Evaluation of a GC–MS method for benzyl chloride content in processed food, meats, and marine products distributed in Korea. (2022). Available at: [\[Link\]](#).
- MDPI. Studies on the Synthesis, Physical Properties, and Stability of Benzyl Ethers as Potential Heat Transfer Fluids. Available at: [\[Link\]](#).
- PubMed. A systematic study of peripherally multiple aromatic ester-functionalized poly(benzyl ether) dendrons for the fabrication of organogels. (2014). Available at: [\[Link\]](#).
- Lab Manager. Spectroscopic Methods in Pharma QA/QC: UV-Vis, IR, and NMR Applications. Available at: [\[Link\]](#).
- Wikipedia. Benzyl alcohol. Available at: [\[Link\]](#).
- Chapter 13 Spectroscopy NMR, IR, MS, UV-Vis. Available at: [\[Link\]](#).
- PubChem. Benzyl Benzoate. Available at: [\[Link\]](#).
- Archives of Case Reports. Chromatography Hyphenated Techniques for the Analysis of Natural Products (A Review). (2025). Available at: [\[Link\]](#).
- IJARST. CHARACTERIZATION OF ISOLATED PHYTOCONSTITUENTS BY DIFFERENT TECHNIQUES LIKE TLC, UV, IR SPECTROSCOPY AND GCMS. (2021). Available at: [\[Link\]](#).
- ResearchGate. Comparative study between various solvents (Reaction conditions: benzyl.... Available at: [\[Link\]](#).

- ResearchGate. Synthesis, spectroscopic characterization (FT-IR, NMR, UV-Vis), DFT study, antibacterial and antioxidant in vitro investigations of 4,6-bis((E)-1-((3-(1H-imidazol-1-yl)propyl)imino)ethyl)benzene-1,3-diol. Available at: [\[Link\]](#).
- UBB. HPLC-PDA VERSUS GC-MS IN THE ANALYSIS OF PARACETAMOL AND NON-STEROIDAL ANTI-INFLAMMATORY DRUGS IN WASTEWATER. (2023). Available at: [\[Link\]](#).
- Properties of Common Organic Solvents. (2022). Available at: [\[Link\]](#).
- ANALYSIS OF FRAGRANCE COMPOUNDS USING THE QP-5000 GC/MS. Available at: [\[Link\]](#).
- PMC. Photocatalytic aerobic oxidative functionalization (PAOF) reaction of benzyl alcohols by GO-MIL-100(Fe) composite in glycerol/K<sub>2</sub>CO<sub>3</sub> deep eutectic solvent. (2022). Available at: [\[Link\]](#).

#### Need Custom Synthesis?

BenchChem offers custom synthesis for rare earth carbides and specific isotopic labeling.

Email: [info@benchchem.com](mailto:info@benchchem.com) or [Request Quote Online](#).

## Sources

- 1. Synthesis of benzyl substituted naphthalenes from benzylidene tetralones - PMC [\[pmc.ncbi.nlm.nih.gov\]](https://pubmed.ncbi.nlm.nih.gov/)
- 2. Impact of Functional Groups in Organic Chemistry on Pharmaceutical Development - Reachem [\[reachemchemicals.com\]](https://reachemchemicals.com/)
- 3. Functional Groups Names, Properties, and Reactions – Introductory Chemistry [\[uen.pressbooks.pub\]](https://uen.pressbooks.pub/)
- 4. uomustansiriyah.edu.iq [\[uomustansiriyah.edu.iq\]](https://uomustansiriyah.edu.iq/)
- 5. mdpi.com [\[mdpi.com\]](https://mdpi.com/)
- 6. Benzyl alcohol - Wikipedia [\[en.wikipedia.org\]](https://en.wikipedia.org/)
- 7. employees.oneonta.edu [\[employees.oneonta.edu\]](https://employees.oneonta.edu/)
- 8. jan.ucc.nau.edu [\[jan.ucc.nau.edu\]](https://jan.ucc.nau.edu/)

- [9. davjalandhar.com](http://9.davjalandhar.com) [[davjalandhar.com](http://davjalandhar.com)]
- [10. chemlab.truman.edu](http://10.chemlab.truman.edu) [[chemlab.truman.edu](http://chemlab.truman.edu)]
- [11. Ester - Structure, Properties, Uses - GeeksforGeeks](http://11.Ester-Structure,Properties,Uses-GeeksforGeeks) [[geeksforgeeks.org](http://geeksforgeeks.org)]
- [12. chembk.com](http://12.chembk.com) [[chembk.com](http://chembk.com)]
- [13. www1.chem.umn.edu](http://13.www1.chem.umn.edu) [[www1.chem.umn.edu](http://www1.chem.umn.edu)]
- [14. lehigh.edu](http://14.lehigh.edu) [[lehigh.edu](http://lehigh.edu)]
- [15. pdf.benchchem.com](http://15.pdf.benchchem.com) [[pdf.benchchem.com](http://pdf.benchchem.com)]
- [16. ijarst.in](http://16.ijarst.in) [[ijarst.in](http://ijarst.in)]
- [17. pdf.benchchem.com](http://17.pdf.benchchem.com) [[pdf.benchchem.com](http://pdf.benchchem.com)]
- To cite this document: BenchChem. [Physical properties of functionalized benzyl naphthoates]. BenchChem, [2026]. [Online PDF]. Available at: [<https://www.benchchem.com/product/b338839#physical-properties-of-functionalized-benzyl-naphthoates>]

---

#### Disclaimer & Data Validity:

The information provided in this document is for Research Use Only (RUO) and is strictly not intended for diagnostic or therapeutic procedures. While BenchChem strives to provide accurate protocols, we make no warranties, express or implied, regarding the fitness of this product for every specific experimental setup.

**Technical Support:** The protocols provided are for reference purposes. Unsure if this reagent suits your experiment? [[Contact our Ph.D. Support Team for a compatibility check](#)]

**Need Industrial/Bulk Grade?** [Request Custom Synthesis Quote](#)

## BenchChem

Our mission is to be the trusted global source of essential and advanced chemicals, empowering scientists and researchers to drive progress in science and industry.

#### Contact

Address: 3281 E Guasti Rd

Ontario, CA 91761, United States

Phone: (601) 213-4426

Email: [info@benchchem.com](mailto:info@benchchem.com)

