

Controlling regioselectivity in cyclohexene ring functionalization

Author: BenchChem Technical Support Team. **Date:** April 2026

Compound of Interest

Compound Name: 1-Cyclohexene-1-propanenitrile

CAS No.: 13992-92-2

Cat. No.: B3378255

[Get Quote](#)

Technical Support Center: Cyclohexene Ring Functionalization Current Status: Online | Agent: Senior Application Scientist | Ticket ID: REGIO-CHX-001

Introduction: The Symmetry Challenge

Welcome to the Cyclohexene Functionalization Support Center. You are likely here because the symmetry of the cyclohexene ring (or the subtle electronic bias of substituted cyclohexenes) is ruining your regioselectivity. Unlike terminal alkenes where steric differentiation is stark, cyclohexene rings often present "flat" energy landscapes that lead to isomeric mixtures.

This guide moves beyond textbook definitions to address the causality of regio-failures in three critical workflows: Allylic C-H Oxidation, Hydrofunctionalization, and Nucleophilic Substitution.

Module 1: Allylic C-H Oxidation (Palladium Catalysis)

The Challenge: Differentiating between allylic sites (C3 vs. C6) in substituted cyclohexenes and preventing over-oxidation to aromatics (oxidative dehydrogenation).

The "White" Protocol (Pd/Sulfoxide Catalysis)

In 1-substituted cyclohexenes (e.g., 1-methylcyclohexene), standard conditions often yield mixtures of endocyclic and exocyclic oxidation. To achieve high regioselectivity for the endocyclic allylic position (typically C3/C6), ligand-controlled electrophilic cleavage is required.

- Mechanism: The reaction proceeds via a

-allyl Pd intermediate.^{[1][2][3]} The C-H cleavage is the rate-determining step (RDS).

Sulfoxide ligands (like those developed by M.C. White) promote this cleavage by acting as a temporary internal base via the coordinated oxygen.

Key Experimental Controls:

- Ligand: Use (PhSO)₂CH₂ (1,2-bis(phenylsulfinyl)ethane) or the specific White catalyst ligand. The sulfoxide binds Pd(II) and makes the metal more electrophilic, promoting C-H cleavage at the most electron-rich allylic position (usually the ring).
- Oxidant: Benzoquinone (BQ) is superior to
for regiocontrol. BQ acts as a ligand to stabilize the Pd(0) species, preventing aggregation and non-selective "wacker-type" oxidation.
- Acid Additive: A specific Brønsted acid (e.g., acetic acid) is required to protonate the benzoquinone-Pd complex, facilitating the regeneration of Pd(II).

Troubleshooting: "Why am I getting benzene?"

If your cyclohexene substrate is converting to a benzene derivative, you are experiencing Oxidative Dehydrogenation.^[4]

- Cause:

-hydride elimination is faster than nucleophilic attack. This occurs when the nucleophile (acetate/alcohol) concentration is too low or the catalyst is too "open" (lacking steric bulk).

- Solution: Increase the concentration of the nucleophile (AcOH) and switch to a more sterically demanding ligand (e.g., a bulky sulfoxide) to retard

-hydride elimination.

Diagram 1: Pd(II)/Sulfoxide Catalytic Cycle & Regioselectivity

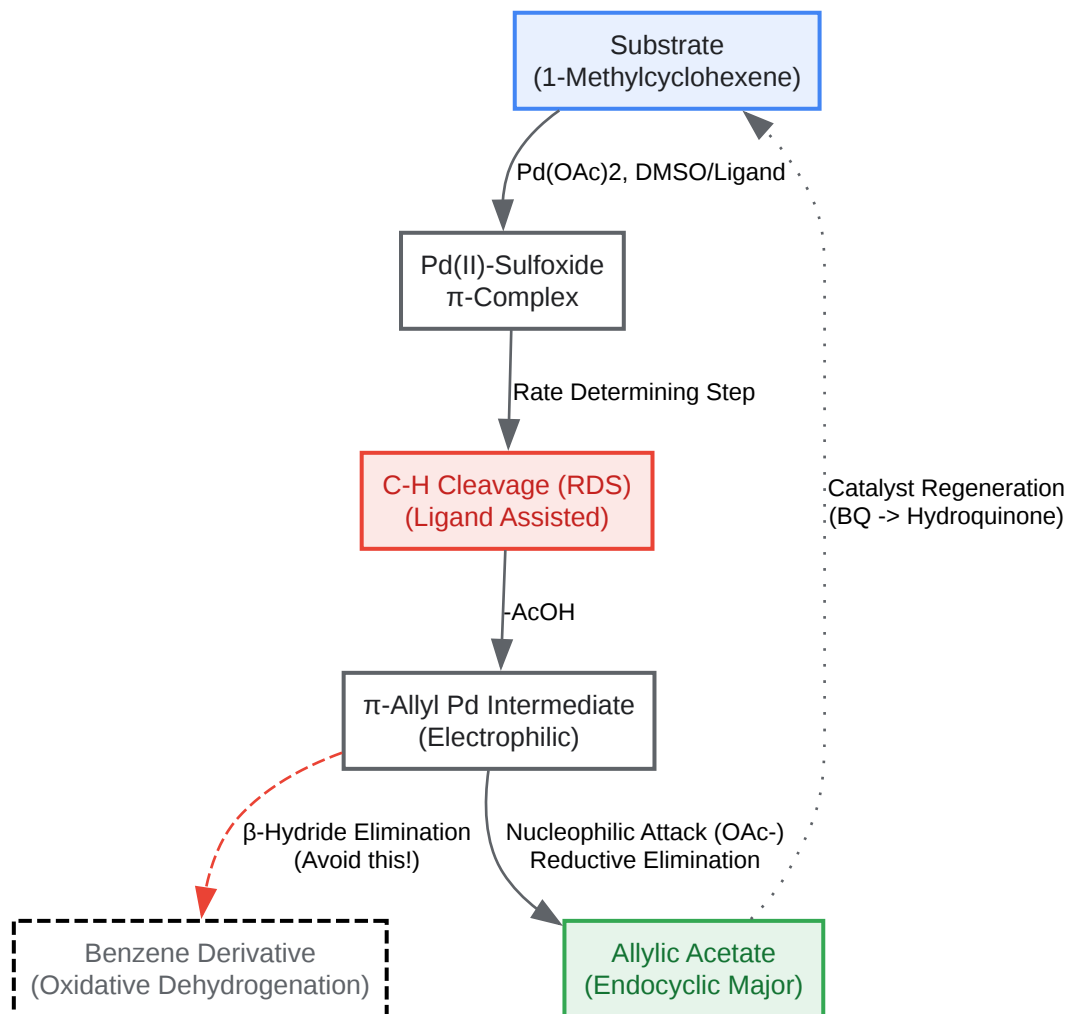

[Click to download full resolution via product page](#)

Caption: The catalytic cycle highlights the critical C-H cleavage step where sulfoxide ligands dictate regioselectivity, preventing the β -hydride elimination pathway.

Module 2: Asymmetric Hydrofunctionalization

The Challenge: Achieving Anti-Markovnikov selectivity on 1-substituted cyclohexenes.

The "Brown" Protocol (Steric Control)

Hydroboration-oxidation of 1-methylcyclohexene theoretically yields trans-2-methylcyclohexanol. However, standard

often gives mixtures because the steric difference between C1 and C2 is insufficient for absolute control.

- Protocol Adjustment: Switch to 9-BBN (9-Borabicyclo[3.3.1]nonane).
- Reasoning: 9-BBN is significantly bulkier than
. It amplifies the steric penalty of the methyl group, forcing the boron atom exclusively to the C2 position (less hindered).
- Stereochemistry: The reaction is stereospecific syn-addition. The H and B add to the same face. Since the methyl group blocks one face, the H/B add anti to the methyl group. Oxidation proceeds with retention of configuration.

Quantitative Comparison:

Reagent	Substrate	Major Product	Regioselectivity (C2:C1)
	1-Methylcyclohexene	trans-2-methylcyclohexanol	~90:10
9-BBN	1-Methylcyclohexene	trans-2-methylcyclohexanol	>99:1
	1-Methylcyclohexene	trans-2-methylcyclohexanol	~97:3

Module 3: Nucleophilic Substitution (Tsuji-Trost)

The Challenge: Controlling

vs.

(Regiomemory) in cyclohexenyl acetates.

The "Memory Effect" Protocol

When functionalizing a cyclohexenyl acetate (e.g., 5-methyl-2-cyclohexenyl acetate), the nucleophile can attack either terminus of the

-allyl system.

- Hard Nucleophiles (e.g., Hydrides, Organozincs): Tend to attack the less substituted position due to steric control.
- Soft Nucleophiles (e.g., Malonates): Often display "Regiomemory." The nucleophile attacks the carbon from which the leaving group departed.
 - Mechanism:^{[1][2][5][6][7][8]} The leaving group (acetate) stays associated with the Pd-cation as an ion pair. It directs the incoming nucleophile to the same site (retention of regiochemistry).

Troubleshooting Workflow:

- Issue: Loss of regiochemical integrity (scrambling).
- Fix: Lower the solvent polarity (THF -> Toluene). High polarity solvents dissociate the ion pair, destroying the memory effect and leading to thermodynamic scrambling.

Troubleshooting Matrix

Symptom	Probable Cause	Corrective Action
Allylic Oxidation: Product is a conjugated enone or benzene.	Over-oxidation / -hydride elimination.	1. Switch oxidant to Benzoquinone (BQ).2.[1] Add 10-20 mol% DMSO or Sulfoxide ligand.3. Lower temperature.
Allylic Oxidation: Low conversion of 1-methylcyclohexene.	Catalyst deactivation (Pd black formation).	Add 5-10 mol% Brønsted acid (AcOH or MSA) to facilitate BQ re-oxidation cycle.
Hydroboration: Mixture of 1-ol and 2-ol isomers.	Steric bulk of Borane is too low.	Switch from to 9-BBN or Catecholborane.
Tsuji-Trost: Nucleophile attacks the "wrong" carbon.	Ion-pair dissociation.	Switch to non-polar solvents (DCM, Toluene) to tighten the Pd-Ligand-LeavingGroup ion pair.

Decision Tree: Selecting the Right Method

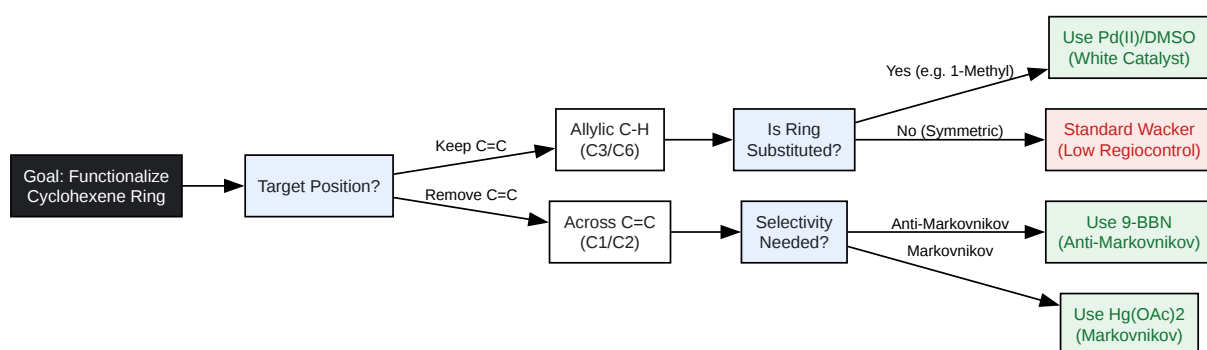

[Click to download full resolution via product page](#)

Caption: Strategic workflow for selecting reagents based on substrate substitution and desired regiochemical outcome.

References

- White, M. C., et al. (2010). "A Predictably Selective Aliphatic C–H Oxidation Reaction for Complex Molecule Synthesis." *Science*. [Link](#)
- Brown, H. C., & Zweifel, G. (1961). "Hydroboration.[9] IX. The Hydroboration of Cyclic and Bicyclic Olefins." *Journal of the American Chemical Society*.^[9] [Link](#)
- Trost, B. M., & Van Vranken, D. L. (1996). "Asymmetric Transition Metal-Catalyzed Allylic Alkylations." *Chemical Reviews*. [Link](#)
- Liao, K., et al. (2016). "Site-Selective and Stereoselective Functionalization of Unactivated C–H Bonds." *Nature*. [Link](#)
- Gusevskaya, E. V., et al. (2004). "Palladium-catalyzed oxidation of monoterpenes: Novel oxidation of limonene with dioxygen." *Applied Catalysis A: General*. [Link](#)^[3]

Need Custom Synthesis?

BenchChem offers custom synthesis for rare earth carbides and specific isotopic labeling.

Email: info@benchchem.com or [Request Quote Online](#).

Sources

- 1. Palladium Catalyzed Allylic C-H Alkylation: A Mechanistic Perspective - PMC [pmc.ncbi.nlm.nih.gov]
- 2. mdpi.com [mdpi.com]
- 3. Palladium-Catalyzed Acetoxylation of γ -Dehydro-aryl-himachalene: The Synthesis of a Novel Allylic Acetoxyated Sesquiterpene and a π -Allyl Palladium(II) Complex - PMC [pmc.ncbi.nlm.nih.gov]
- 4. Palladium-Catalyzed Aerobic Oxidative Dehydrogenation of Cyclohexenes to Substituted Arene Derivatives - PMC [pmc.ncbi.nlm.nih.gov]
- 5. What is the major product of the following reaction? Cyclohexene methyl .. [askfilo.com]

- [6. researchgate.net \[researchgate.net\]](#)
- [7. mdpi.com \[mdpi.com\]](#)
- [8. Selective Catalytic Oxidation of Cyclohexene with Molecular Oxygen: Radical Versus Nonradical Pathways - PMC \[pmc.ncbi.nlm.nih.gov\]](#)
- [9. chemrxiv.org \[chemrxiv.org\]](#)
- To cite this document: BenchChem. [Controlling regioselectivity in cyclohexene ring functionalization]. BenchChem, [2026]. [Online PDF]. Available at: [\[https://www.benchchem.com/product/b3378255/docs#controlling-regioselectivity-in-cyclohexene-ring-functionalization\]](https://www.benchchem.com/product/b3378255/docs#controlling-regioselectivity-in-cyclohexene-ring-functionalization)

Disclaimer & Data Validity:

The information provided in this document is for Research Use Only (RUO) and is strictly not intended for diagnostic or therapeutic procedures. While BenchChem strives to provide accurate protocols, we make no warranties, express or implied, regarding the fitness of this product for every specific experimental setup.

Technical Support: The protocols provided are for reference purposes. Unsure if this reagent suits your experiment?

Need Industrial/Bulk Grade? [Request Custom Synthesis Quote](#)

BenchChem

Our mission is to be the trusted global source of essential and advanced chemicals, empowering scientists and researchers to drive progress in science and industry.

Contact

Address: 3281 E Guasti Rd

Ontario, CA 91761, United States

Phone: (601) 213-4426

Email: info@benchchem.com

Contact our Ph.D. Support Team for a compatibility check