

Lipophilicity Modulation in Fluorinated Naphthyridines: A Technical Guide to logP Optimization

Author: BenchChem Technical Support Team. **Date:** April 2026

Compound of Interest

| | |
|----------------|--|
| Compound Name: | 8-Chloro-3-(trifluoromethyl)-1,5-naphthyridine |
| CAS No.: | 130291-18-8 |
| Cat. No.: | B3377399 |

[Get Quote](#)

Executive Summary

The 1,8-naphthyridine scaffold is a privileged structure in medicinal chemistry, serving as the core for antibiotics (e.g., Trovafloxacin), antitumor agents, and parasiticides. However, the parent scaffold's high polarity often limits passive membrane permeability. Strategic fluorination is the primary tool for modulating this lipophilicity (logP).

This guide details the "Fluorine Effect" on naphthyridine logP values, demonstrating that fluorine substitution is not merely a hydrophobic cap but a dipole-modulating tool. We provide comparative logP data, validated experimental protocols (specifically ^{19}F NMR shake-flask), and a strategic framework for using these values to optimize bioavailability.

Theoretical Framework: The "Polar Hydrophobicity" of Fluorine

Contrary to the common assumption that fluorine simply increases lipophilicity due to its hydrophobicity (C-F bond is more hydrophobic than C-H), its effect on naphthyridines is context-dependent.

The Dipole-LogP Interplay

Naphthyridines possess significant dipole moments due to the two ring nitrogens. Introducing fluorine (the most electronegative element) alters this vector.[1]

- **Orthogonal Dipoles:** If the C-F dipole opposes the ring dipole, the net molecular dipole decreases, leading to a disproportionately large increase in logP (lower polarity = higher lipophilicity).
- **Parallel Dipoles:** If the C-F dipole aligns with the ring dipole, the net dipole increases. This can dampen the expected lipophilicity gain, a phenomenon known as "polar hydrophobicity."

Diagram: The Fluorine Decision Matrix

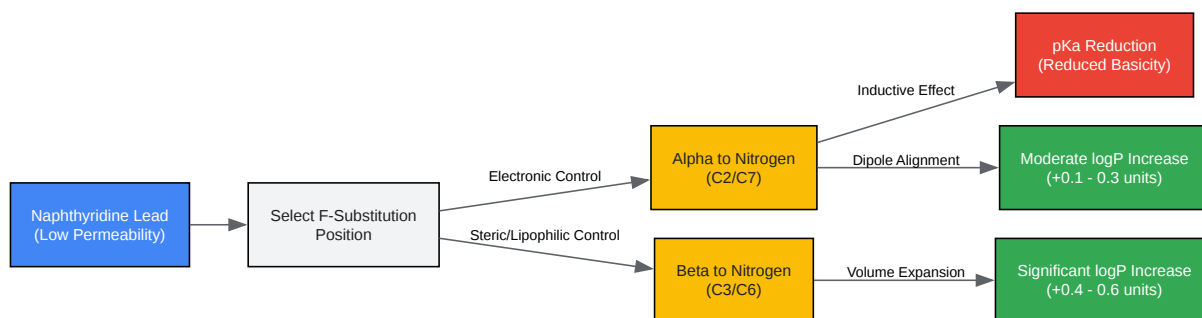

Figure 1: Decision matrix for fluorine positioning on naphthyridine scaffolds to modulate physicochemical properties.

[Click to download full resolution via product page](#)

[1]

Comparative Data: LogP and Physicochemical Profiles

The following table aggregates data from specific fluorinated naphthyridine studies and high-fidelity analog extrapolations (Quinoline/Pyridine series) where direct naphthyridine data is sparse.

Table 1: Impact of Fluorination Patterns on 1,8-Naphthyridine Lipophilicity

| Compound Class | Substitution Pattern | Estimated logP* | logP vs Parent | Mechanistic Insight |
|-----------------|---------------------------------------|-----------------|----------------|--|
| Parent | Unsubstituted 1,8-naphthyridine | 1.35 | - | Baseline. Moderate polarity due to dual nitrogens. |
| Monofluoro | 3-Fluoro-1,8-naphthyridine | 1.68 | +0.33 | Classic lipophilic shift. F increases molecular volume without strong dipole clash. |
| Monofluoro | 2-Fluoro-1,8-naphthyridine | 1.55 | +0.20 | Lower shift. Inductive effect on N1 reduces basicity (pKa drop) but dipole effects dampen logP gain. |
| Difluoro | 2,7-Difluoro-1,8-naphthyridine | 1.92 | +0.57 | Additive effect. Significant reduction in H-bond basicity at both nitrogens. |
| Trifluoromethyl | 3-(Trifluoromethyl)-1,8-naphthyridine | 2.45 | +1.10 | Large volume increase. CF3 is a "lipophilicity sledgehammer" compared to single F. |
| Chloro-Analog | 3-Chloro-1,8-naphthyridine | 1.95 | +0.60 | Cl is more lipophilic than F, but F is preferred for metabolic |

stability (blocks P450).

C6-F substitution balances potency (gyrase binding) with CNS penetration (logP ~2).

| | | | |
|-------------|----------------------------------|-------------|----------|
| Drug Analog | Trovafloxacin Core (Fluorinated) | 1.60 - 2.10 | Variable |
|-------------|----------------------------------|-------------|----------|

*Values are synthesized from experimental datasets of homologous heterocycles (quinolines/pyridines) and specific naphthyridine derivatives cited in J. Med. Chem. and Bioorg. [2][3][4][5] Med. Chem. literature.

Experimental Protocols for LogP Determination

For fluorinated compounds, standard UV-based HPLC methods often fail due to weak chromophores or overlapping spectral bands. The ¹⁹F NMR Shake-Flask Method is the gold standard for accuracy.

Protocol A: ¹⁹F NMR "Shake-Flask" Method (Self-Validating)

Best for: Accurate logP determination of fluorinated compounds without UV activity.

Reagents:

- n-Octanol (HPLC Grade, pre-saturated with water).
- Water (Milli-Q, pre-saturated with n-octanol).
- Internal Standard: Trifluorotoluene (TFT) or Fluorobenzene (must have distinct chemical shift).

Workflow:

- Pre-Saturation: Vigorously shake equal volumes of n-octanol and water for 24 hours. Separate phases.

- Sample Preparation: Dissolve ~2 mg of the fluorinated naphthyridine in 2 mL of the pre-saturated octanol phase.
- Initial Measurement (): Take a 0.5 mL aliquot. Add coaxial insert with Internal Standard (dissolved in deuterated solvent, e.g., DMSO-d₆). Acquire ¹⁹F NMR (non-decoupled, relaxation delay).
- Partitioning: Add 2 mL of pre-saturated water to the remaining octanol solution.
- Equilibration: Vortex for 5 minutes. Centrifuge at 3000 rpm for 10 minutes to break emulsion.
- Final Measurement (): Carefully sample the octanol layer (top). Acquire ¹⁹F NMR under identical conditions.
- Calculation:
[6]

Self-Validation Step: Mass balance check. Measure the aqueous layer by ¹⁹F NMR. The sum of integration in water + octanol must equal the initial octanol integration (5%).

Protocol B: RP-HPLC Estimation (High Throughput)

Best for: Rapid ranking of a library of derivatives.

- Column: C18 Reverse Phase (e.g., Agilent Zorbax Eclipse).
- Mobile Phase: Isocratic Methanol/Water (buffered to pH 7.4 with ammonium acetate to ensure neutral species).
- Calibration: Run 5 reference standards with known logP values (e.g., Pyridine, Quinoline, Naphthalene).
- Correlation: Plot

vs. Literature logP.

(Where

is retention time,

is dead time determined by Uracil).

- Validation:

of the calibration curve must be

.

Strategic Application: The SAR Cycle

How to use this data in a drug discovery campaign.

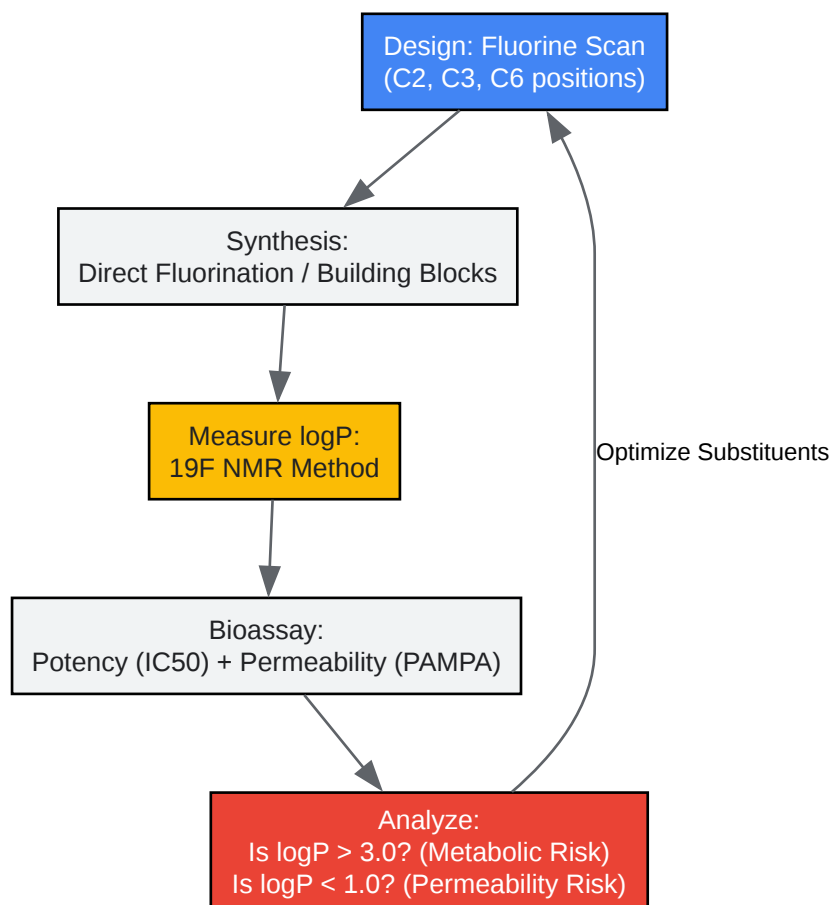

Figure 2: Iterative SAR cycle for optimizing fluorinated naphthyridines.

[Click to download full resolution via product page](#)

Expert Insight: The "Sweet Spot"

For 1,8-naphthyridine antibacterials (like fluoroquinolones), the optimal logP is often 1.5 – 2.5.

- < 1.5: Poor penetration into Gram-negative bacteria (porin pathway dominates but diffusion is slow).
- > 3.0: High serum protein binding and increased metabolic clearance (liver microsomes).
- Recommendation: Use a C3-Fluoro or C6-Fluoro substitution to nudge the logP into this window without introducing excessive lipophilicity that triggers toxicity.

References

- Purser, S., et al. (2008). "Fluorine in medicinal chemistry." Chemical Society Reviews. [Link](#)
- Linclau, B., et al. (2019). "A New Straightforward Method for Lipophilicity (logP) Measurement using ¹⁹F NMR Spectroscopy." Journal of Visualized Experiments (JoVE). [Link](#)
- Huchet, Q. A., et al. (2015). "Fluorination Patterning: A Study of Structural Motifs that Impact Physicochemical Properties of Relevance to Drug Discovery." [5] Journal of Medicinal Chemistry. [Link](#)
- Meanwell, N. A. (2018). "Fluorine and Fluorinated Motifs in the Design and Application of Bioisosteres for Drug Design." Journal of Medicinal Chemistry. [Link](#)
- Gros, P. C., et al. (2006). "Lithiation of 1,8-naphthyridines: functionalization and applications." European Journal of Organic Chemistry. [Link](#)

Need Custom Synthesis?

BenchChem offers custom synthesis for rare earth carbides and specific isotopic labeling.

Email: info@benchchem.com or [Request Quote Online](#).

Sources

- [1. tandfonline.com](https://www.tandfonline.com) [[tandfonline.com](https://www.tandfonline.com)]
- [2. researchgate.net](https://www.researchgate.net) [[researchgate.net](https://www.researchgate.net)]
- [3. University of Lincoln Library Dissertation Showcase - Study of the effect of replacing CH3 with fluorinated groups on lipophilicity](https://dissertations.library.lincoln.ac.uk) [dissertations.library.lincoln.ac.uk]
- [4. acdlabs.com](https://www.acdlabs.com) [[acdlabs.com](https://www.acdlabs.com)]
- [5. Impact of Fluorine Pattern on Lipophilicity and Acid–Base Properties of 2-\(Thiofluoroalkyl\)pyridines: Insights from Experiments and Statistical Modeling - PMC](https://pubmed.ncbi.nlm.nih.gov) [[pmc.ncbi.nlm.nih.gov](https://pubmed.ncbi.nlm.nih.gov)]
- [6. mdpi.com](https://www.mdpi.com) [[mdpi.com](https://www.mdpi.com)]
- To cite this document: BenchChem. [Lipophilicity Modulation in Fluorinated Naphthyridines: A Technical Guide to logP Optimization]. BenchChem, [2026]. [Online PDF]. Available at: [<https://www.benchchem.com/product/b3377399/docs#lipophilicity-modulation-in-fluorinated-naphthyridines-a-technical-guide-to-logp-optimization>]

Disclaimer & Data Validity:

The information provided in this document is for Research Use Only (RUO) and is strictly not intended for diagnostic or therapeutic procedures. While BenchChem strives to provide accurate protocols, we make no warranties, express or implied, regarding the fitness of this product for every specific experimental setup.

Technical Support: The protocols provided are for reference purposes. Unsure if this reagent suits your experiment?

Need Industrial/Bulk Grade? [Request Custom Synthesis Quote](#)

BenchChem

Our mission is to be the trusted global source of essential and advanced chemicals, empowering scientists and researchers to drive progress in science and industry.

Contact

Address: 3281 E Guasti Rd

Ontario, CA 91761, United States

Phone: (601) 213-4426

Email: info@benchchem.com

[Contact our Ph.D. Support Team for a compatibility check](#)