

Technical Support Center: Optimizing Azetidinone Mesylate Reactions with Thiols

Author: BenchChem Technical Support Team. **Date:** April 2026

Compound of Interest

Compound Name: (4-oxoazetidin-2-yl)methyl
methanesulfonate

CAS No.: 103883-23-4

Cat. No.: B3374758

[Get Quote](#)

Introduction

Welcome to the Technical Support Center. As Senior Application Scientists, we understand the nuances and challenges of synthetic chemistry. This guide is designed to provide you, our fellow researchers and drug development professionals, with in-depth technical guidance and troubleshooting advice for a crucial reaction: the nucleophilic substitution of azetidinone mesylates with thiols.

The 2-azetidinone (or β -lactam) ring is a cornerstone of many life-saving antibiotics, including penicillins and cephalosporins.[1][2] Its inherent ring strain, a result of its four-membered structure, makes it both a potent biological agent and a sensitive synthetic intermediate.[3] The reaction of a 4-mesyloxy-2-azetidinone with a thiol is a key step in creating a diverse range of thioether derivatives, often as precursors to advanced antibiotic candidates like thienamycin. The mesylate group serves as an excellent leaving group, facilitating an S_N2 reaction with a thiol nucleophile. However, the success of this reaction is highly dependent on carefully controlled conditions, with temperature being one of the most critical parameters.

This guide will delve into the mechanistic underpinnings of this reaction, provide actionable FAQs, and offer a systematic troubleshooting framework to help you optimize your reaction temperature for maximum yield and purity.

Reaction Mechanism: The S_N2 Pathway

The reaction proceeds via a bimolecular nucleophilic substitution (S_N2) mechanism. The process is initiated by a base, which deprotonates the thiol (R-SH) to form a more nucleophilic thiolate anion (R-S⁻). This powerful nucleophile then attacks the carbon atom at the 4-position of the azetidinone ring from the side opposite the mesylate leaving group. The reaction occurs in a single, concerted step where the C-S bond forms simultaneously as the C-OMs bond breaks.

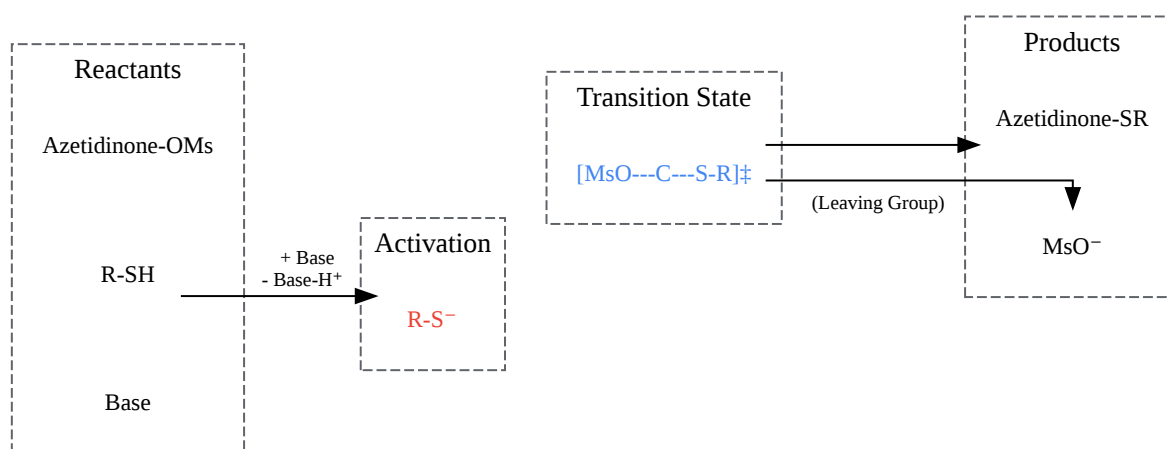

[Click to download full resolution via product page](#)

Caption: S_N2 reaction of an azetidinone mesylate with a thiol.

Understanding this mechanism is crucial. For instance, the backside attack dictates the stereochemistry of the product. More importantly for this guide, the energy required to overcome the activation barrier of the transition state is directly influenced by temperature.

Frequently Asked Questions (FAQs)

Q1: What is the optimal starting temperature for this reaction?

There is no single "optimal" temperature; it is highly dependent on the specific substrates. However, a good starting point for most reactions involving aliphatic or simple aromatic thiols is room temperature (20-25°C). Many reactions of azetidinones are successfully carried out at room temperature to preserve the sensitive β -lactam ring.[4][5] For less reactive thiols (e.g., sterically hindered or electron-deficient aromatic thiols), gentle heating to 40-60°C may be necessary. It is always recommended to start at a lower temperature and gradually increase it while monitoring the reaction progress.

Q2: How does increasing the temperature affect the reaction rate and yield?

According to the Arrhenius equation, increasing the reaction temperature generally increases the rate of reaction. This is because more molecules will possess the necessary activation energy to overcome the transition state barrier.

- **Positive Effect:** For slow or stalled reactions, raising the temperature can be the key to driving the reaction to completion. In some multi-component reactions, moving from room temperature to reflux conditions has been shown to significantly increase yield in the same timeframe.[6]
- **Negative Effects:** Excessive heat can be detrimental. The strained β -lactam ring is susceptible to thermal degradation, leading to ring-opening and the formation of polymeric side products.[7] Furthermore, high temperatures can promote side reactions, such as elimination or reactions with the solvent, ultimately lowering the overall yield of the desired product.

Q3: My reaction is not proceeding at room temperature. What should I do?

If you observe no product formation after several hours at room temperature (as confirmed by TLC or LC-MS), you should consider the following, in order:

- **Confirm Thiol Activation:** Ensure your base is strong enough to deprotonate the thiol. For aliphatic thiols, a tertiary amine like triethylamine (TEA) is often sufficient.[8][9] For less

acidic aromatic thiols, a stronger base like DBU (1,8-Diazabicyclo[11.5.4.0]undec-7-ene) or sodium hydride (NaH) may be required.

- **Incremental Temperature Increase:** Raise the temperature in 10°C increments, holding for 1-2 hours at each new temperature while monitoring the reaction. This methodical approach allows you to find the minimum temperature required for the reaction to proceed, minimizing degradation.
- **Solvent Choice:** Ensure you are using an appropriate solvent. Polar aprotic solvents like DMF, DMSO, or acetonitrile are generally preferred as they can solvate the ions involved without interfering with the reaction.

Q4: I'm seeing multiple new spots on my TLC plate after heating the reaction. What's happening?

The appearance of multiple spots, especially those with very different polarities, is a strong indicator of side reactions or product degradation, often caused by excessive heat.

- **Possible Side Reactions:**
 - **β-Lactam Cleavage:** The most common degradation pathway. Amide bonds can be cleaved under harsh conditions.
 - **Elimination:** If there is a proton on the carbon adjacent to the mesylate, an E2 elimination reaction can occur, forming an unsaturated azetidinone.
 - **Oxidation of Thiol:** If oxygen is not excluded from the reaction, the highly reactive thiolate can be oxidized to a disulfide (R-S-S-R).

To mitigate this, immediately reduce the temperature. If the reaction requires elevated temperatures to proceed, consider using a more reactive (less hindered) thiol or a more potent nucleophile-base system to allow the reaction to occur at a lower temperature.

Troubleshooting Guide

This section provides a systematic approach to resolving common issues encountered during the optimization process.

Problem Encountered	Potential Cause	Recommended Action
Low or No Product Formation	1. Insufficient Temperature	Gradually increase temperature in 10-15°C increments, monitoring via TLC/LC-MS.
2. Ineffective Base	Switch to a stronger base (e.g., from TEA to DBU) to ensure complete thiolate formation.	
3. Poor Leaving Group (Rare for Mesylate)	Confirm the identity and purity of your azetidinone mesylate starting material.	
Reaction Stalls Before Completion	1. Catalyst/Reagent Degradation	If using a phase-transfer catalyst, it may not be stable at the reaction temperature.
2. Reversible Reaction	The back reaction is generally not favorable, but ensure the leaving group anion (MsO^-) is not interfering.	
3. Depletion of Base	The base can be consumed by acidic impurities. Add an additional portion of base (0.1-0.2 equivalents).[10]	
Formation of Multiple Side Products	1. Temperature is Too High	Immediately lower the reaction temperature. Aim for the lowest possible temperature that allows for a reasonable reaction rate.
2. Oxygen Contamination	Purge the reaction vessel with an inert gas (Nitrogen or Argon) to prevent disulfide formation.	

3. Unstable Substrates	The azetidinone or thiol starting materials may be degrading under the reaction conditions. Check their stability independently at the reaction temperature.	
Low Isolated Yield Despite Full Conversion	1. Product Instability	The thioether product may be unstable to the workup or purification conditions (e.g., silica gel chromatography).
2. Product is Water-Soluble	Modify the aqueous workup (e.g., brine wash, back-extraction) to minimize loss of a polar product.	

Troubleshooting Workflow

Caption: A systematic workflow for troubleshooting the reaction.

Experimental Protocols

Protocol 1: General Procedure for the Reaction

This protocol provides a starting point. Volumes and equivalents should be adjusted based on the specific molecular weights of your reactants.

Materials:

- 4-mesyloxy-2-azetidinone (1.0 eq)
- Thiol (1.1 - 1.2 eq)
- Triethylamine (TEA) (1.5 eq)
- Anhydrous Dimethylformamide (DMF)
- Round-bottom flask, magnetic stirrer, nitrogen/argon inlet

Procedure:

- To a dry round-bottom flask under an inert atmosphere (N₂ or Ar), add the 4-mesyloxy-2-azetidinone and dissolve it in anhydrous DMF (approx. 0.1 M concentration).
- Add the thiol to the solution and stir for 5 minutes.
- Add triethylamine dropwise to the stirred solution at room temperature.
- Stir the reaction at room temperature and monitor its progress every 1-2 hours.
- If no significant progress is observed after 4-6 hours, slowly heat the reaction to 40°C. Continue to monitor.
- Once the reaction is complete, cool the mixture to room temperature.
- Pour the reaction mixture into a separatory funnel containing ethyl acetate and water.
- Extract the aqueous layer with ethyl acetate (3x).
- Combine the organic layers, wash with brine, dry over anhydrous sodium sulfate (Na₂SO₄), filter, and concentrate under reduced pressure.
- Purify the crude product by flash column chromatography.

Protocol 2: Monitoring Reaction Progress by Thin-Layer Chromatography (TLC)

Materials:

- TLC plates (e.g., silica gel 60 F₂₅₄)
- Developing chamber
- Mobile phase (e.g., a mixture of ethyl acetate and hexanes)
- Visualization agent (e.g., UV lamp, potassium permanganate stain)

Procedure:

- Prepare a developing chamber with the chosen mobile phase. The polarity should be chosen so that the starting material has an R_f value of approximately 0.5-0.6.
- Before adding the base (time = 0), take a small aliquot of the reaction mixture with a capillary tube and spot it on the TLC plate. This is your starting material reference.
- After the reaction has started, take aliquots at regular intervals (e.g., every hour).
- Spot the aliquots on the same TLC plate next to the reference spot.
- Develop the plate in the prepared chamber.
- Visualize the plate under a UV lamp. The disappearance of the starting material spot and the appearance of a new spot (the product) indicates the reaction is proceeding. The product is often more non-polar than the mesylate starting material.
- The reaction is considered complete when the starting material spot is no longer visible.

For more quantitative analysis, High-Performance Liquid Chromatography (HPLC) or Nuclear Magnetic Resonance (NMR) spectroscopy can be employed.[\[11\]](#)[\[12\]](#)

References

- Azetidinone: Different methods of synthesis and its biological profile. (n.d.). Der Pharma Chemica.
- Recent Advances in the Synthesis and Reactivity of Azetidines: Strain-Driven Character of the Four-Membered Heterocycle. (2021). RSC Publishing.
- A REVIEW ON 2-AZETEDINONES. (2015). Journal of Global Trends in Pharmaceutical Sciences.
- BIOACTIVE AZETIDINONE: A REVIEW. (n.d.). TIJER.org.
- Synthesis of 2-Azetidinones via Cycloaddition Approaches: An Upd
- Optimization of the reaction conditions. (n.d.).
- Scalable Thiol Reactivity Profiling Identifies Azetidiny Oxadiazoles as Cysteine-targeting Electrophiles. (n.d.). PMC.
- Synthesis and biological study of Azetidinone derivatives. (2019).
- Synthesis and Biological Evaluation of New 2-Azetidinones with Sulfonamide Structures. (n.d.). MDPI.

- 2-AZETIDINONE DERIVATIVES: SYNTHESIS, ANTIMICROBIAL, ANTICANCER EVALUATION AND QSAR STUDIES. (n.d.). Acta Pharmaceutica Scientia.
- Analytical techniques for reaction monitoring, mechanistic investigations, and metal complex discovery. (2021). UVicSpace.
- Synthesis of 2-Azetidinones via Cycloaddition Approaches: An Update. (2024).
- Synthesis and biological evaluation of azetidinone derivatives from 2- α (phenylacetyl) benzohydrazide moiety by microwave method. (n.d.). Der Pharma Chemica.
- Properties and reactions of 4-thioxo-2-azetidinones. (n.d.). Academia.edu.
- 1.2 Azetidinones (~Lactams). (n.d.). Comprehensive Organic Chemistry.
- Troubleshooting low yield in N3-peptide synthesis. (2025). Benchchem.
- Analytical Methods for Assessing Thiol Antioxidants in Biological Fluids: A Review. (2024). PMC.
- 4-Alkyl-thio- and -dithio-azetidinones from penicillins. (n.d.). Journal of the Chemical Society D.
- Azetidinones. (2014). International Journal of Pharmaceutical Sciences Review and Research.
- A BRIEF REVIEW ON THIAZOLIDINONES AND AZETIDINONES: SYNTHESIS AND BIOLOGICAL ACTIVITIES. (n.d.). Journal of Advanced Scientific Research.
- Example for azetidine synthesis by nucleophilic substitution. (n.d.).
- Synthesis of 2-Azetidinones via Cycloaddition Approaches: An Upd
- Kinetic studies on nucleophilic substitution reactions of O-aryl thionobenzoates with azide, cyanide, and hydroxide: contrasting reactivity and mechanism. (2009). PubMed.
- Kinetics of Nucleophilic Substitution of Compounds Containing Multiple Leaving Groups Bound to a Neopentyl Skeleton. (2022). PMC.
- Biochemical methods for monitoring protein thiol redox st
- Impact of temperature on the physico-chemical stability of Azacitidine Zentiva 25 mg/ml suspensions packaged in polypropylene syringes. (2021). GERPAC.
- Analytical Methods for Assessing Thiol Antioxidants in Biological Fluids: A Review. (2024). PubMed.
- Methods for the determination and quantification of the reactive thiol proteome. (n.d.). PMC - NIH.
- optimizing reaction conditions for 1,3-diyne synthesis (temper

Need Custom Synthesis?

BenchChem offers custom synthesis for rare earth carbides and specific isotopic labeling.

Email: info@benchchem.com or [Request Quote Online](#).

Sources

- [1. derpharmachemica.com \[derpharmachemica.com\]](#)
- [2. One moment, please... \[tijer.org\]](#)
- [3. pubs.rsc.org \[pubs.rsc.org\]](#)
- [4. Synthesis and Biological Evaluation of New 2-Azetidinones with Sulfonamide Structures - PMC \[pmc.ncbi.nlm.nih.gov\]](#)
- [5. mdpi.com \[mdpi.com\]](#)
- [6. researchgate.net \[researchgate.net\]](#)
- [7. bhu.ac.in \[bhu.ac.in\]](#)
- [8. chemijournal.com \[chemijournal.com\]](#)
- [9. derpharmachemica.com \[derpharmachemica.com\]](#)
- [10. pdf.benchchem.com \[pdf.benchchem.com\]](#)
- [11. Analytical techniques for reaction monitoring, mechanistic investigations, and metal complex discovery \[dspace.library.uvic.ca\]](#)
- [12. Analytical Methods for Assessing Thiol Antioxidants in Biological Fluids: A Review - PMC \[pmc.ncbi.nlm.nih.gov\]](#)
- [To cite this document: BenchChem. \[Technical Support Center: Optimizing Azetidinone Mesylate Reactions with Thiols\]. BenchChem, \[2026\]. \[Online PDF\]. Available at: \[https://www.benchchem.com/product/b3374758/docs#technical-support-center-optimizing-azetidinone-mesylate-reactions-with-thiols\]](#)

Disclaimer & Data Validity:

The information provided in this document is for Research Use Only (RUO) and is strictly not intended for diagnostic or therapeutic procedures. While BenchChem strives to provide accurate protocols, we make no warranties, express or implied, regarding the fitness of this product for every specific experimental setup.

Technical Support: The protocols provided are for reference purposes. Unsure if this reagent suits your experiment?

Need Industrial/Bulk Grade? [Request Custom Synthesis Quote](#)

BenchChem

Our mission is to be the trusted global source of essential and advanced chemicals, empowering scientists and researchers to drive progress in science and industry.

Contact

Address: 3281 E Guasti Rd

Ontario, CA 91761, United States

Phone: (601) 213-4426

Email: info@benchchem.com

[Contact our Ph.D. Support Team for a compatibility check](#)