

Revolutionizing Aryloxyacetic Acid Synthesis: A Guide to Microwave-Assisted Methodologies

Author: BenchChem Technical Support Team. **Date:** April 2026

Compound of Interest

Compound Name: 2-(3-Fluorophenoxy)-2-phenylacetic acid

CAS No.: 1016520-75-4

Cat. No.: B3373825

[Get Quote](#)

Introduction: The Imperative for Greener, Faster Chemistry

Phenoxy phenylacetic acids and their derivatives are a cornerstone in medicinal chemistry and materials science, exhibiting a wide range of biological activities, including antibacterial, anti-inflammatory, and herbicidal properties.[1][2][3] The traditional synthesis of these vital compounds, often reliant on the Williamson ether synthesis, is typically hampered by long reaction times, high energy consumption, and often, the use of hazardous solvents.[4] In our continuous pursuit of more efficient and environmentally benign chemical transformations, microwave-assisted organic synthesis (MAOS) has emerged as a transformative technology.[5][6][7] This application note provides a comprehensive guide for researchers, scientists, and drug development professionals on the application of microwave irradiation to the synthesis of phenoxy phenylacetic acids, offering detailed protocols and a comparative analysis against conventional heating methods.

The Engine of Acceleration: Understanding Microwave-Assisted Synthesis

Microwave-assisted synthesis leverages the ability of dielectric materials, such as polar solvents and reactants, to absorb microwave energy and convert it into heat. This heating mechanism is fundamentally different from conventional heating, where heat is transferred from an external source through the vessel walls to the reaction mixture. In contrast, microwave irradiation leads to rapid, uniform, and efficient heating of the bulk reaction mixture.^{[5][6][8]}

The primary mechanisms of microwave heating are:

- **Dipolar Polarization:** Polar molecules in the reaction mixture attempt to align themselves with the rapidly oscillating electric field of the microwaves. This constant reorientation creates molecular friction, generating heat.^{[6][9]}
- **Ionic Conduction:** In the presence of ions, the oscillating electric field induces their migration. Collisions between these moving ions and other molecules in the solution result in the dissipation of energy as heat.^[6]

This direct and instantaneous heating often leads to a dramatic acceleration of reaction rates, sometimes by several orders of magnitude, allowing reactions that would take hours under conventional reflux to be completed in a matter of minutes.^{[10][11]}

Workflow of Microwave-Assisted Synthesis

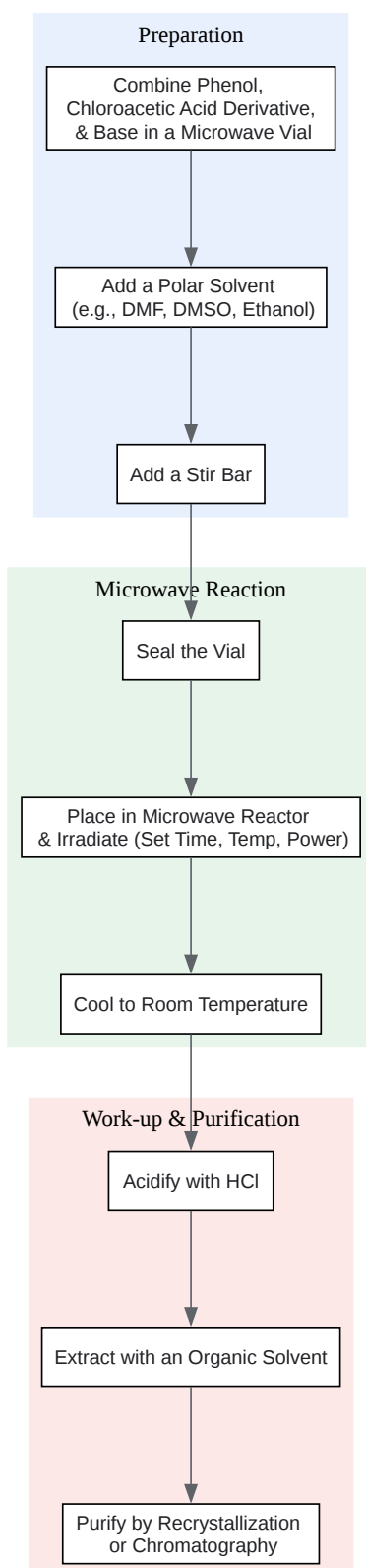

[Click to download full resolution via product page](#)

Caption: A generalized workflow for the microwave-assisted synthesis of phenoxy phenylacetic acids.

Core Reaction: The Microwave-Enhanced Williamson Ether Synthesis

The synthesis of phenoxy phenylacetic acids primarily relies on the Williamson ether synthesis, a robust and versatile method for forming carbon-oxygen bonds.[4][12] In this reaction, a phenoxide, generated in situ by the deprotonation of a phenol with a base, acts as a nucleophile and attacks an α -haloacetic acid derivative (e.g., chloroacetic acid) in an SN2 reaction.[12][13]

Reaction Scheme

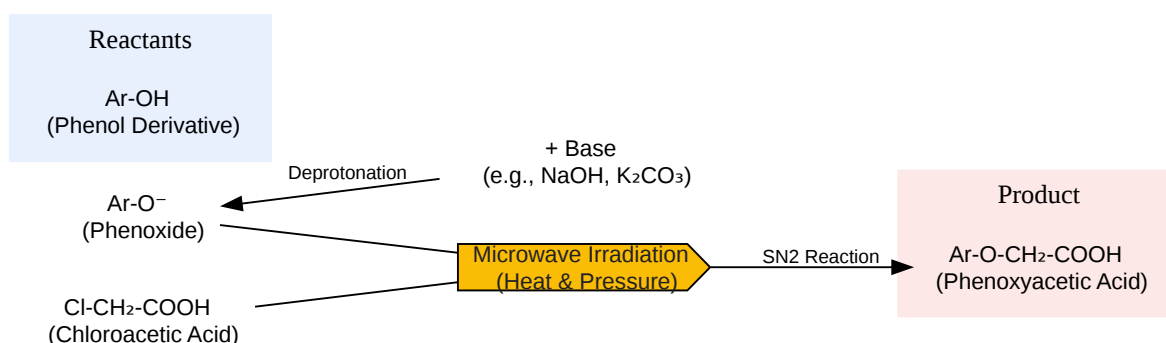

[Click to download full resolution via product page](#)

Caption: The general reaction scheme for the Williamson ether synthesis of phenoxyacetic acids.

Experimental Protocols: A Step-by-Step Guide

Herein, we provide detailed protocols for the microwave-assisted synthesis of a representative phenoxy phenylacetic acid.

Protocol 1: Microwave-Assisted Synthesis of 2-(4-phenyldiazenyl)phenoxy)acetic acid

This protocol is adapted from a comparative study which highlights the efficiency of microwave synthesis.[1]

Materials:

- 4-(phenyldiazenyl)phenol
- Chloroacetic acid
- Sodium hydroxide
- Water
- Microwave synthesis vial (10-20 mL) with a magnetic stir bar
- Microwave synthesizer

Procedure:

- **Reactant Preparation:** In a microwave synthesis vial, combine 4-(phenyldiazenyl)phenol (1 mmol), chloroacetic acid (1.1 mmol), and a solution of sodium hydroxide (2.5 mmol in 5 mL of water).
- **Vial Sealing:** Securely seal the vial with a cap.
- **Microwave Irradiation:** Place the vial in the cavity of the microwave synthesizer. Irradiate the mixture for 6 minutes at a power and temperature optimized for the specific instrument to maintain a consistent reaction environment.
- **Cooling:** After the irradiation is complete, allow the vial to cool to room temperature.
- **Work-up:** Open the vial and acidify the reaction mixture with dilute hydrochloric acid until a precipitate forms.

- Isolation and Purification: Collect the solid product by filtration, wash with cold water, and dry. The crude product can be further purified by recrystallization from a suitable solvent system (e.g., ethanol/water).

Comparative Analysis: Microwave vs. Conventional Synthesis

The advantages of microwave-assisted synthesis are most evident when directly compared to conventional heating methods.[\[11\]](#)

Parameter	Conventional Synthesis [1]	Microwave-Assisted Synthesis [1]
Reaction Time	Several hours (reflux)	5-10 minutes
Yield	42-43%	78-85%
Energy Consumption	High	Significantly Lower [6] [8]
Solvent Usage	Often requires organic solvents	Can often be performed in water or solvent-free [1] [8]
Product Purity	May require extensive purification due to side products	Generally higher purity, simplifying work-up [5] [7]

Advantages of Microwave-Assisted Synthesis in Drug Discovery and Development

The adoption of microwave technology offers significant benefits for professionals in drug development:

- Accelerated Lead Optimization: The ability to rapidly synthesize libraries of analogs allows for faster structure-activity relationship (SAR) studies.[\[5\]](#)
- Improved Reproducibility: Dedicated microwave reactors provide precise control over reaction parameters, leading to more reproducible results compared to conventional heating.[\[5\]](#)

- Scalability: While initial studies are performed on a small scale, microwave synthesis can be scaled up to produce larger quantities of promising drug candidates.[5]
- Green Chemistry: By reducing reaction times, energy consumption, and the use of hazardous solvents, microwave synthesis aligns with the principles of green chemistry, making drug development processes more sustainable.[6][7][8]

Conclusion: A Paradigm Shift in Synthesis

Microwave-assisted synthesis represents a paradigm shift in the preparation of phenoxy phenylacetic acids and other valuable organic compounds. The dramatic reduction in reaction times, coupled with increased yields and a more favorable environmental profile, makes it an indispensable tool for the modern research and development laboratory. By embracing this technology, scientists can accelerate the discovery and development of new therapeutics and materials.

References

- Microwaves in Organic Synthetic Chemistry- A Greener Approach to Environmental Protection: An Overview. (2024, January 15). Google Scholar.
- Importance of Microwave Heating in Organic Synthesis - Advanced Journal of Chemistry, Section A. (2019, January 2). ajchem-a.com. [\[Link\]](#)
- Microwave-Assisted Organic Synthesis: A Green Chemistry Strategy - International Journal of Research in Pharmacy and Allied Science. (2025, June 30). ijrpa.com. [\[Link\]](#)
- THE ROLE OF MICROWAVE -ASSISTED SYNTHESIS IN ORGANIC CHEMISTRY. (2024, October 12). researchgate.net. [\[Link\]](#)
- CONVENTIONAL AND GREEN SYNTHESIS UNDER SOLVENT-FREE MICROWAVE IRRADIATION OF 2-(4-(PHENYLDIAZENYL)PHENOXY) ACETIC ACID DERIVATIV - Farmacia Journal. (2021, February 11). farmaciajournal.com. [\[Link\]](#)
- Biological Profile and Synthesis of Phenoxyacetic Acid Derivatives: A Review - Jetir.Org. jetir.org. [\[Link\]](#)

- Recent investigations into synthesis and pharmacological activities of phenoxy acetamide and its derivatives (chalcone, indole and quinoline) as possible therapeutic candidates - PMC. (2021, February 1). NIH. [\[Link\]](#)
- Phenoxyacetic acid - Wikipedia. Wikipedia. [\[Link\]](#)
- COMPARATIVE STUDY OF CONVENTIONAL AND MICROWAVE INDUCED SYNTHESIS OF SELECTED HETEROCYCLIC MOLECULES. ijpbs.net. [\[Link\]](#)
- Synthesis and evaluation of phenoxy acetic acid derivatives as anti-mycobacterial agents. (2025, August 5). Google Scholar.
- CONVENTIONAL AND GREEN SYNTHESIS UNDER SOLVENT-FREE MICROWAVE IRRADIATION OF 2-(4-(PHENYLDIAZENYL)PHENOXY) ACETIC ACID DERIVATIVES AND THEIR BIOLOGICAL ACTIVITY. Semantic Scholar. [\[Link\]](#)
- Conventional vs microwave assisted synthesis of different substituted heterocyclic amides - Indian Chemical Society. indianchemicalsociety.com. [\[Link\]](#)
- Microwave Assisted Williamson Synthesis: A Green Approach Towards the Preparation of Ethers - ResearchGate. ResearchGate. [\[Link\]](#)
- Microwave Assisted Williamson Synthesis: A Green Approach Towards the Preparation of Ethers | Bentham Science. (2024, October 11). Bentham Science. [\[Link\]](#)
- Microwave-Assisted Synthesis, Lipophilicity and In Vitro Antimicrobial Activity of Hydrazone-Hydrazones of Phenylacetic Acid - MDPI. (2025, March 21). mdpi.com. [\[Link\]](#)
- Comparative study of conventional and microwave assisted synthesis. biorxiv.org. [\[Link\]](#)
- Microwave Assisted Ethers Synthesis - Organic Chemistry. (2016, November 22). tsijournals.com. [\[Link\]](#)
- Williamson ether synthesis - Wikipedia. Wikipedia. [\[Link\]](#)
- A Tandem Scalable Microwave-Assisted Williamson Alkyl Aryl Ether Synthesis under Mild Conditions - Organic Chemistry Research. orgchemres.org. [\[Link\]](#)

- Method for synthesizing phenoxyacetic acid derivative - Google Patents.
- (PDF) Microwave-Assisted Synthesis of 2-Phenoxybenzoic Acids - ResearchGate. ResearchGate. [[Link](#)]
- MICROWAVE ASSISTED ORGANIC SYNTHESIS: A GREEN CHEMISTRY APPROACH - IJNRD. (2023, June 6). [ijnrd.org](#). [[Link](#)]

Need Custom Synthesis?

BenchChem offers custom synthesis for rare earth carbides and specific isotopic labeling.

Email: info@benchchem.com or [Request Quote Online](#).

Sources

- 1. [farmaciajournal.com](#) [[farmaciajournal.com](#)]
- 2. [jetir.org](#) [[jetir.org](#)]
- 3. Recent investigations into synthesis and pharmacological activities of phenoxy acetamide and its derivatives (chalcone, indole and quinoline) as possible therapeutic candidates - PMC [[pmc.ncbi.nlm.nih.gov](#)]
- 4. [hakon-art.com](#) [[hakon-art.com](#)]
- 5. [ajchem-a.com](#) [[ajchem-a.com](#)]
- 6. [ijrpas.com](#) [[ijrpas.com](#)]
- 7. [researchgate.net](#) [[researchgate.net](#)]
- 8. [ajgreenchem.com](#) [[ajgreenchem.com](#)]
- 9. [ijnrd.org](#) [[ijnrd.org](#)]
- 10. Microwave-assisted synthesis | Anton Paar Wiki [[wiki.anton-paar.com](#)]
- 11. [sphinxsai.com](#) [[sphinxsai.com](#)]
- 12. Williamson ether synthesis - Wikipedia [[en.wikipedia.org](#)]
- 13. Phenoxyacetic acid - Wikipedia [[en.wikipedia.org](#)]
- To cite this document: BenchChem. [Revolutionizing Aryloxyacetic Acid Synthesis: A Guide to Microwave-Assisted Methodologies]. BenchChem, [2026]. [Online PDF]. Available at:

[<https://www.benchchem.com/product/b3373825/docs#revolutionizing-aryloxyacetic-acid-synthesis-a-guide-to-microwave-assisted-methodologies>]

Disclaimer & Data Validity:

The information provided in this document is for Research Use Only (RUO) and is strictly not intended for diagnostic or therapeutic procedures. While BenchChem strives to provide accurate protocols, we make no warranties, express or implied, regarding the fitness of this product for every specific experimental setup.

Technical Support: The protocols provided are for reference purposes. Unsure if this reagent suits your experiment?

Need Industrial/Bulk Grade? [Request Custom Synthesis Quote](#)

BenchChem

Our mission is to be the trusted global source of essential and advanced chemicals, empowering scientists and researchers to drive progress in science and industry.

Contact

Address: 3281 E Guasti Rd
Ontario, CA 91761, United States
Phone: (601) 213-4426
Email: info@benchchem.com

[Contact our Ph.D. Support Team for a compatibility check](#)