

# 1-Butenylcyclopentane: Comprehensive Chemical Identifiers and Analytical Methodologies

**Author:** BenchChem Technical Support Team. **Date:** April 2026

## Compound of Interest

Compound Name:	1-Butenylcyclopentane
CAS No.:	219726-62-2
Cat. No.:	B3368821

[Get Quote](#)

## Executive Summary

As a Senior Application Scientist, navigating the complexities of volatile organic compounds (VOCs) requires an uncompromising grasp of chemical identifiers and robust analytical frameworks. **1-Butenylcyclopentane** (C<sub>9</sub>H<sub>16</sub>), a cycloalkane derivative featuring an exocyclic butenyl chain, is a critical analyte across diverse disciplines—ranging from forensic taphonomy (cadaveric VOC profiling) to food chemistry and waste-to-energy pyrolysis. This whitepaper synthesizes the fundamental chemical identifiers of **1-butenylcyclopentane**, explores its physicochemical properties, and establishes a self-validating gas chromatography-mass spectrometry (GC-MS) protocol for its precise quantification.

## Chemical Nomenclature and Core Identifiers

Accurate chemical identification is the bedrock of reproducible research. **1-Butenylcyclopentane** exists in multiple stereoisomeric forms, predominantly the trans-(E) configuration, which dictates its specific registry numbers and structural descriptors[1].

## Primary Identifiers

The structural ambiguity of cycloalkane derivatives often leads to database discrepancies. To ensure rigorous cross-referencing, the identifiers must be strictly delineated based on stereochemistry. The trans isomer is formally designated as [(E)-but-1-enyl]cyclopentane[1].

Table 1: Standardized Chemical Identifiers

Descriptor	Value	Context / Specificity
IUPAC Name	[(E)-but-1-enyl]cyclopentane	Systematic nomenclature[1]
CAS Registry Number	157724-07-7	Specific to trans-1-butenylcyclopentane[1]
Alternative CAS	219726-62-2	Unspecified stereochemistry[2]
Molecular Formula	C9H16	Base hydrocarbon structure[1]
SMILES	<chem>CC/C=C/C1CCCC1</chem>	Isomeric SMILES string[1]
InChIKey	VBTJJCNOBRVHLY-ZZXKWWIFSA-N	Hash for database querying[1]
DSSTox ID	DTXSID001016244	EPA chemical registry[1]

## Physicochemical Properties

Understanding the thermodynamic and spatial properties of **1-butenylcyclopentane** is essential for predicting its behavior in chromatographic systems and biological matrices. Its high lipophilicity and lack of polar surface area dictate its high volatility and affinity for non-polar extraction phases[1].

Table 2: Computed and Experimental Properties

Property	Value	Analytical Implication
Molecular Weight	124.22 g/mol	Determines m/z range in MS detection[1]
Exact Mass	124.1252 Da	High-resolution MS target mass[1]
XLogP3	3.7	Indicates strong partitioning into non-polar matrices[1]
Topological Polar Surface Area	0 Å <sup>2</sup>	Zero hydrogen bonding potential; dictates GC column choice[1]
Rotatable Bonds	3	Influences conformational flexibility and entropy of vaporization[1]

## Origins and Multi-Disciplinary Significance

**1-Butenylcyclopentane** is rarely synthesized as a primary industrial product; rather, it is a diagnostic biomarker and a byproduct of complex organic degradation pathways.

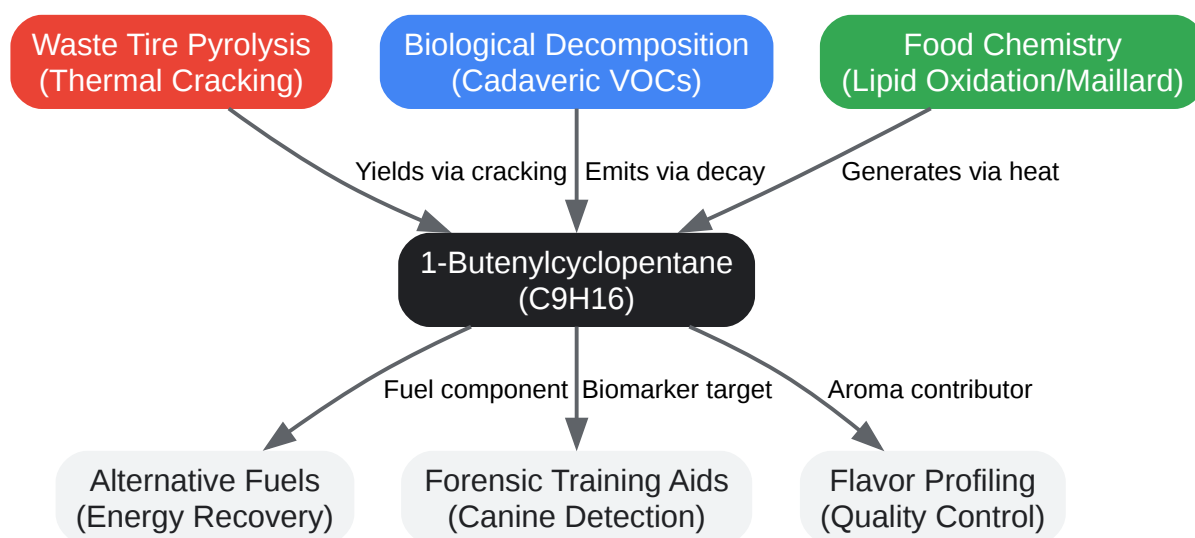

[Click to download full resolution via product page](#)

Origins and downstream applications of **1-butenylcyclopentane** across various scientific fields.

- Forensic Taphonomy: It is identified as a key volatile emitted during human decomposition, making it a critical target in developing synthetic training aids for cadaver-detection canines[3].
- Waste-to-Energy Pyrolysis: Advanced refining of waste tires yields complex hydrocarbon mixtures (pyrolysis oils) where **1-butenylcyclopentane** serves as a constituent of liquid fuels, impacting the fuel's calorific value and combustion profile[4].
- Food Science: Detected in the volatile profile of cooked meats (e.g., Jinhua ham), where cyclic hydrocarbons contribute to the complex sensory matrix of cooked animal tissues[5].

## Self-Validating Analytical Protocol: SPME-GC-MS Detection

To isolate and quantify a highly volatile, non-polar analyte like **1-butenylcyclopentane** from complex matrices (e.g., decomposition fluid or pyrolysis oil), Solid Phase Microextraction (SPME) coupled with Gas Chromatography-Mass Spectrometry (GC-MS) is the gold standard[3][5].

The following protocol is designed as a self-validating system, meaning built-in physicochemical checks ensure that any failure in extraction or separation is immediately identifiable.

### Step-by-Step Methodology & Mechanistic Causality

#### Step 1: Matrix Preparation & Headspace Equilibration

- Action: Place 2.0 g (or 2.0 mL) of the sample matrix into a 20 mL headspace vial. Add 1.0 mL of saturated NaCl solution (if the matrix is aqueous) and seal with a PTFE/silicone septum. Incubate at 50°C for 15 minutes.
- Causality: The addition of NaCl induces a "salting-out" effect, decreasing the solubility of non-polar organics in the aqueous phase and driving **1-butenylcyclopentane** into the

headspace. The 50°C incubation accelerates thermodynamic equilibrium according to Henry's Law without causing thermal degradation of thermolabile co-extractants.

#### Step 2: Solid Phase Microextraction (SPME)

- Action: Expose a 50/30 µm Divinylbenzene/Carboxen/Polydimethylsiloxane (DVB/CAR/PDMS) SPME fiber to the headspace for 30 minutes at 50°C.
- Causality: A mixed-bed fiber is chosen over a pure PDMS fiber because the sample matrix often contains a wide dynamic range of VOCs[3]. While PDMS effectively captures the non-polar **1-butenylcyclopentane**, the DVB and CAR phases ensure that lower molecular weight and slightly polar co-analytes are also retained, providing a complete chromatographic fingerprint for matrix validation.

#### Step 3: Thermal Desorption & GC Injection

- Action: Retract the fiber and immediately insert it into the GC inlet set to 250°C. Desorb for 3 minutes in splitless mode.
- Causality: 250°C is above the boiling point of C<sub>9</sub>H<sub>16</sub> but below the thermal degradation threshold of the fiber coating. Splitless injection ensures maximum transfer of the trace analyte onto the column head, critical for low-abundance biomarker detection.

#### Step 4: Chromatographic Separation

- Action: Utilize an HP-5MS (or equivalent 5% phenyl / 95% dimethylpolysiloxane) capillary column (30 m × 0.25 mm × 0.25 µm). Oven program: 40°C (hold 2 min), ramp at 5°C/min to 150°C, then 15°C/min to 280°C (hold 5 min).
- Causality: The non-polar stationary phase separates analytes primarily by boiling point and dispersive van der Waals interactions. The slow initial ramp (5°C/min) is strictly necessary to resolve **1-butenylcyclopentane** from other closely related C<sub>9</sub>-C<sub>10</sub> cyclic and branched aliphatic isomers.

#### Step 5: Mass Spectrometric Detection & Validation

- Action: Operate the MS in Electron Ionization (EI) mode at 70 eV. Scan range: m/z 35 to 300.

- Causality: 70 eV is the universal standard for EI, ensuring the resulting fragmentation pattern can be directly cross-referenced against the NIST mass spectral library[5].
- Self-Validation Check: The protocol is validated internally by verifying the presence of the molecular ion peak ( $M^+$  at  $m/z$  124) and characteristic fragmentation ions (e.g., loss of the butenyl radical). If the baseline exhibits excessive siloxane peaks ( $m/z$  73, 207, 281), it indicates column or fiber bleed, invalidating the run and prompting immediate maintenance.

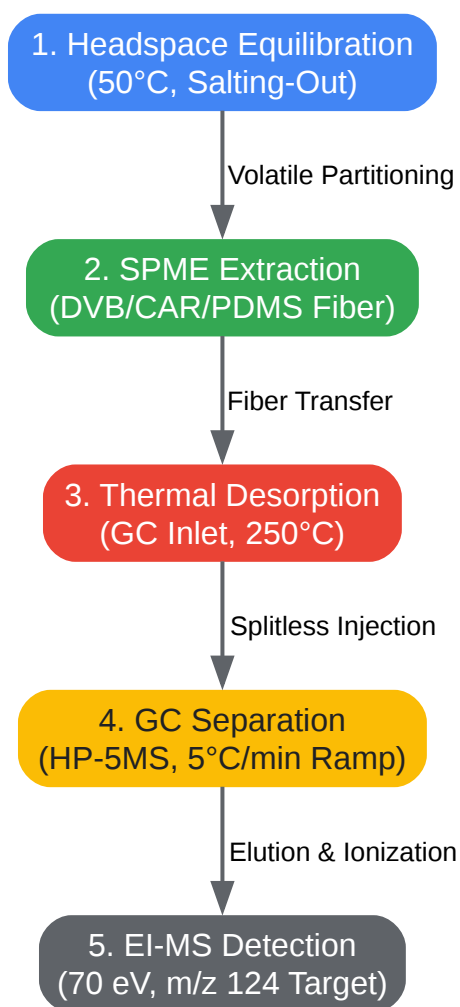

[Click to download full resolution via product page](#)

Self-validating SPME-GC-MS workflow for the extraction and detection of **1-butenylcyclopentane**.

## Conclusion

**1-Butenylcyclopentane** is a highly specific, non-polar volatile biomarker with profound implications across forensic science, food chemistry, and advanced fuel refining. By standardizing its chemical identifiers—specifically differentiating the trans isomer (CAS 157724-07-7) from the general structural registry (CAS 219726-62-2)—researchers can ensure database integrity. Furthermore, implementing a mechanistically grounded SPME-GC-MS protocol guarantees that the extraction and quantification of this C<sub>9</sub>H<sub>16</sub> cycloalkane are both reproducible and analytically unassailable.

## References

- National Center for Biotechnology Information. "PubChem Compound Summary for CID 5365707, trans-**1-Butenylcyclopentane**." PubChem,
- MOLBASE. "**1-Butenylcyclopentane** / trans-**1-Butenylcyclopentane** CAS No.: 219726-62-2." MOLBASE Chemical Encyclopedia,
- Rust, L. "The validation of human decomposition fluid as a cadaver-detection dog training aid." University of Technology Sydney (OPUS), 2016.
- Dang, Y. L., et al. "Effect of Cooking Methods on the Flavor of Jinhua Ham by GC-MS and Electronic Nose Analysis." Advance Journal of Food Science and Technology, Maxwell Science, 2016.
- Royal Society of Chemistry.

### Need Custom Synthesis?

BenchChem offers custom synthesis for rare earth carbides and specific isotopic labeling.

Email: [info@benchchem.com](mailto:info@benchchem.com) or [Request Quote Online](#).

## Sources

- [1. trans-1-Butenylcyclopentane | C<sub>9</sub>H<sub>16</sub> | CID 5365707 - PubChem \[pubchem.ncbi.nlm.nih.gov\]](#)
- [2. molbase.com \[molbase.com\]](#)
- [3. opus.lib.uts.edu.au \[opus.lib.uts.edu.au\]](#)
- [4. rsc.org \[rsc.org\]](#)
- [5. maxwellsci.com \[maxwellsci.com\]](#)

- To cite this document: BenchChem. [1-Butenylcyclopentane: Comprehensive Chemical Identifiers and Analytical Methodologies]. BenchChem, [2026]. [Online PDF]. Available at: [<https://www.benchchem.com/product/b3368821/docs#1-butenylcyclopentane-comprehensive-chemical-identifiers-and-analytical-methodologies>]

---

### Disclaimer & Data Validity:

The information provided in this document is for Research Use Only (RUO) and is strictly not intended for diagnostic or therapeutic procedures. While BenchChem strives to provide accurate protocols, we make no warranties, express or implied, regarding the fitness of this product for every specific experimental setup.

**Technical Support:** The protocols provided are for reference purposes. Unsure if this reagent suits your experiment?

**Need Industrial/Bulk Grade?** [Request Custom Synthesis Quote](#)

## BenchChem

Our mission is to be the trusted global source of essential and advanced chemicals, empowering scientists and researchers to drive progress in science and industry.

### Contact

Address: 3281 E Guasti Rd

Ontario, CA 91761, United States

Phone: (601) 213-4426

Email: [info@benchchem.com](mailto:info@benchchem.com)

[Contact our Ph.D. Support Team for a compatibility check](#)