

Mass Spectrometry Fragmentation Pattern of Fluorinated Benzyl Alcohols: A Comparative Guide

Author: BenchChem Technical Support Team. **Date:** April 2026

Compound of Interest

Compound Name:	(2,5-Difluoro-4-methoxyphenyl)methanol
CAS No.:	922719-76-4
Cat. No.:	B3361568

[Get Quote](#)

Executive Summary

Fluorinated benzyl alcohols (C_7H_7FO , MW 126.13 Da) are critical intermediates in the synthesis of bioactive pharmaceutical ingredients (APIs) and common metabolites of fluorinated drugs. While their molecular weights are identical, the position of the fluorine atom (ortho, meta, or para) significantly influences their physicochemical properties and, to a lesser extent, their mass spectral fragmentation.

This guide provides an in-depth analysis of the Electron Ionization (EI) fragmentation pathways, highlighting the dominance of the fluorotropylium ion and the subtle "ortho effects" that can aid in isomer differentiation.

Mechanistic Fragmentation Analysis

The Dominant Pathway: Fluorotropylium Ion Formation

Regardless of the isomer, the fragmentation of fluorobenzyl alcohols is dominated by the cleavage of the benzylic hydroxyl group. This process follows a well-established mechanism analogous to non-fluorinated benzyl alcohol but is electronically modulated by the fluorine substituent.

- **Molecular Ion Formation:** The molecule ionizes to form the radical cation at m/z 126.
- **-Cleavage (Loss of OH):** The benzylic C-O bond breaks, expelling a hydroxyl radical ().
- **Ring Expansion:** The resulting fluorobenzyl cation () is unstable and rapidly rearranges into the seven-membered, aromatic fluorotropylium ion () at m/z 109.



Expert Insight: The m/z 109 peak is almost invariably the base peak (100% relative abundance) in the spectra of all three isomers. This limits the utility of single-stage MS for isomer differentiation, necessitating high-resolution chromatography or MS/MS analysis of secondary fragments.

Secondary Fragmentation Pathways

The fluorotropylium ion (m/z 109) possesses high internal energy and undergoes further fragmentation:

- **Loss of Acetylene ():** The tropylium ring contracts, expelling neutral acetylene to form the ion at m/z 83.

- Loss of HF: A characteristic pathway for fluorinated aromatics is the elimination of hydrogen fluoride (20 Da).[2] This can occur from the molecular ion (yielding m/z 106) or from the tropylium ion (yielding m/z 89).

Isomer Differentiation: The "Ortho Effect"

While the spectra are similar, the ortho- isomer (2-fluorobenzyl alcohol) exhibits unique behaviors due to the proximity of the fluorine atom to the benzylic hydroxyl group.

- Facilitated HF Elimination: In the ortho- isomer, the fluorine atom and the hydroxyl hydrogen are in close spatial proximity. This facilitates a 4-membered transition state elimination of HF, potentially enhancing the abundance of the [M-HF]

peak at m/z 106 relative to the meta- and para- isomers.

- Benzylic Hydrogen Loss: The loss of a benzylic hydrogen atom to form the fluorobenzaldehyde cation (

) at m/z 125 is observed. The intensity of this peak can vary based on the electronic resonance stabilization provided by the fluorine position (Para > Ortho > Meta).

Visualization of Fragmentation Pathways

The following diagram illustrates the primary and secondary fragmentation pathways.

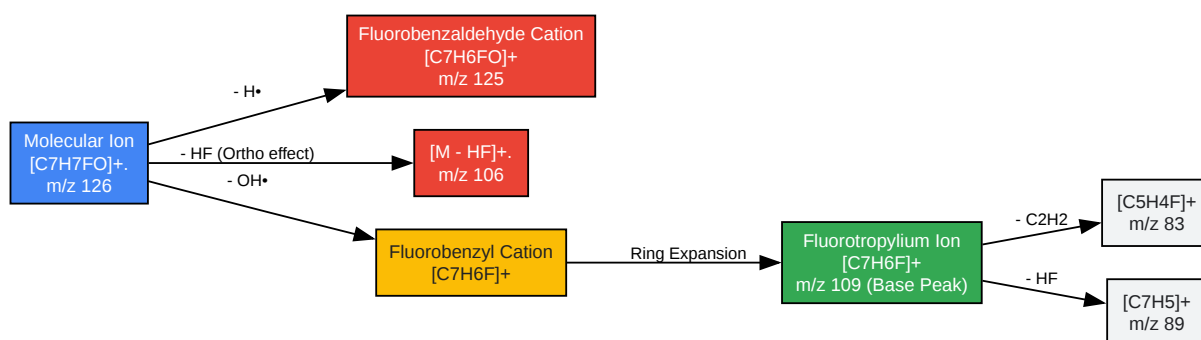

[Click to download full resolution via product page](#)

Caption: Mechanistic pathway showing the formation of the diagnostic fluorotropylium ion and secondary fragments.

Comparative Data Analysis

The following table summarizes the expected relative abundances of key ions. Note that absolute intensities vary by instrument tuning (e.g., quadrupole vs. ion trap), but the ratios provide diagnostic value.

Ion Fragment	m/z	Identity	2-Fluoro (Ortho)	3-Fluoro (Meta)	4-Fluoro (Para)
	126	Molecular Ion	Moderate (~20-30%)	Moderate (~20-30%)	Moderate (~20-30%)
	125	Fluorobenzaldehyde cation	Low	Low	Medium (Resonance stabilized)
	109	Fluorotropylium (Base)	100%	100%	100%
	106	Radical cation	Distinct Trace	Very Low	Very Low
	83	Ring contraction product	High	High	High

Key Differentiator: The para- isomer often shows a slightly more intense m/z 125 peak due to the ability of the fluorine lone pairs to stabilize the positive charge on the carbonyl-like carbon through resonance, a mechanism less effective in the meta- position. The ortho- isomer is best distinguished by the potential [M-HF] peak and retention time.

Experimental Protocol: Self-Validating GC-MS Workflow

To ensure reproducibility and accurate identification, the following protocol integrates chromatographic separation with mass spectral detection. This "orthogonal" approach compensates for the spectral similarity of the isomers.

Sample Preparation

- **Dissolution:** Dissolve 1 mg of the fluorobenzyl alcohol sample in 1 mL of HPLC-grade Ethyl Acetate.
- **Derivatization (Optional but Recommended):** To enhance isomer separation and peak shape, add 50 μ L of BSTFA (N,O-Bis(trimethylsilyl)trifluoroacetamide) + 1% TMCS. Incubate at 60°C for 30 minutes.
 - **Note:** This converts alcohols to TMS-ethers, shifting the molecular ion to m/z 198 and the base peak to m/z 183 ([M-CH₃]⁺).
- **Filtration:** Filter through a 0.22 μ m PTFE syringe filter into a GC vial.

GC-MS Method Parameters

- **Instrument:** Single Quadrupole GC-MS (e.g., Agilent 5977 or equivalent).
- **Column:** DB-5ms or equivalent (30 m \times 0.25 mm \times 0.25 μ m). The non-polar phase is standard, but a polar column (e.g., DB-Wax) provides superior separation for free alcohol isomers.
- **Carrier Gas:** Helium at 1.0 mL/min (Constant Flow).
- **Inlet:** Split mode (20:1), 250°C.
- **Oven Program:**
 - Hold at 60°C for 1 min.
 - Ramp 10°C/min to 200°C.
 - Ramp 25°C/min to 280°C, hold 3 min.

- MS Source: Electron Ionization (EI) at 70 eV, 230°C.[3]
- Scan Range: m/z 40–300.

Workflow Diagram

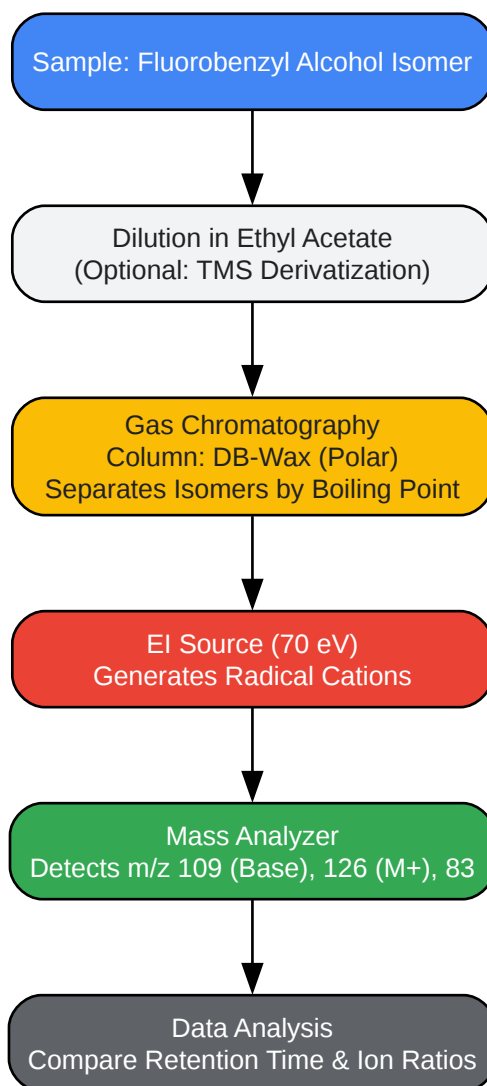

[Click to download full resolution via product page](#)

Caption: Step-by-step GC-MS workflow for the analysis of fluorobenzyl alcohols.

References

- NIST Chemistry WebBook. 2-Fluorobenzyl alcohol Mass Spectrum. National Institute of Standards and Technology.[3][4] Available at: [\[Link\]](#)

- Van Outersterp, R. E., et al. (2020). Mass spectrometry-based identification of ortho-, meta- and para-isomers using infrared ion spectroscopy.[5] The Analyst.[2] Available at: [\[Link\]](#)
- Murakami, T., et al. (2016).[6] Differentiation of AB-FUBINACA positional isomers by the abundance of product ions using electron ionization-triple quadrupole mass spectrometry.[6] Journal of Mass Spectrometry.[6] Available at: [\[Link\]](#)
- Gross, J. H. (2017). Mass Spectrometry: A Textbook. Springer International Publishing. (General reference for Tropylium mechanism).

Need Custom Synthesis?

BenchChem offers custom synthesis for rare earth carbides and specific isotopic labeling.

Email: info@benchchem.com or [Request Quote Online](#).

Sources

- 1. chemrxiv.org [chemrxiv.org]
- 2. whitman.edu [whitman.edu]
- 3. tsapps.nist.gov [tsapps.nist.gov]
- 4. 2-Fluorobenzyl alcohol [webbook.nist.gov]
- 5. Mass spectrometry-based identification of ortho -, meta - and para -isomers using infrared ion spectroscopy - Analyst (RSC Publishing) DOI:10.1039/D0AN01119C [pubs.rsc.org]
- 6. Differentiation of AB-FUBINACA positional isomers by the abundance of product ions using electron ionization-triple quadrupole mass spectrometry - PubMed [pubmed.ncbi.nlm.nih.gov]
- To cite this document: BenchChem. [Mass Spectrometry Fragmentation Pattern of Fluorinated Benzyl Alcohols: A Comparative Guide]. BenchChem, [2026]. [Online PDF]. Available at: [<https://www.benchchem.com/product/b3361568/docs#mass-spectrometry-fragmentation-pattern-of-fluorinated-benzyl-alcohols-a-comparative-guide>]

Disclaimer & Data Validity:

The information provided in this document is for Research Use Only (RUO) and is strictly not intended for diagnostic or therapeutic procedures. While BenchChem strives to provide accurate protocols, we make no warranties, express or implied, regarding the fitness of this product for every specific experimental setup.

Technical Support: The protocols provided are for reference purposes. Unsure if this reagent suits your experiment?

Need Industrial/Bulk Grade? [Request Custom Synthesis Quote](#)

BenchChem

Our mission is to be the trusted global source of essential and advanced chemicals, empowering scientists and researchers to drive progress in science and industry.

Contact

Address: 3281 E Guasti Rd
Ontario, CA 91761, United States
Phone: (601) 213-4426
Email: info@benchchem.com

[Contact our Ph.D. Support Team for a compatibility check](#)