

Application Note: Microwave-Assisted Synthesis of Furan-Oxazole Derivatives

Author: BenchChem Technical Support Team. **Date:** April 2026

Compound of Interest

Compound Name:	5-(furan-3-yl)oxazole-4-carboxylic acid
CAS No.:	88352-89-0
Cat. No.:	B3360088

[Get Quote](#)

Abstract

This application note details a robust, high-yield protocol for the synthesis of furan-oxazole derivatives using microwave-assisted organic synthesis (MAOS). Furan-oxazole hybrids are privileged scaffolds in medicinal chemistry, exhibiting potent antibacterial, antifungal, and anticancer activities. Traditional thermal synthesis of these heterocycles (e.g., via Robinson-Gabriel or Fischer methods) often suffers from prolonged reaction times (3–12 hours), harsh dehydrating conditions, and low atom economy.

This guide presents two validated microwave protocols:

- The Van Leusen [3+2] Cycloaddition for 5-substituted oxazoles.
- The Modified Ortoleva-King Reaction for 2-aminooxazoles.

Both methods demonstrate significant improvements over conventional heating, reducing reaction times to under 10 minutes while increasing yields by 15–30%.^[1]

Introduction & Mechanistic Rationale

The Furan-Oxazole Scaffold

The fusion of a furan ring (an oxygen-rich 5-membered heterocycle) with an oxazole core creates a "heteroaryl-heteroaryl" hybrid. This structure mimics various bioactive natural products and allows for diverse hydrogen bonding interactions with biological targets, such as bacterial DNA gyrase or fungal CYP51 enzymes.

Why Microwave Irradiation?

Conventional synthesis relies on conductive heating, which creates thermal gradients and often leads to decomposition of the sensitive furan ring before the oxazole cyclization is complete. Microwave irradiation utilizes dielectric heating, where dipolar molecules (solvents like ethanol or reagents like TosMIC) align with the oscillating electric field. This molecular friction generates rapid, uniform internal heat, accelerating the reaction rate (Arrhenius law) and selectively activating the transition states for cyclization.

Protocol A: Van Leusen [3+2] Cycloaddition

Target: 5-(Furan-2-yl)oxazole derivatives. Mechanism: Base-mediated cycloaddition of p-toluenesulfonylmethyl isocyanide (TosMIC) with furan-2-carboxaldehyde (furfural).

Reaction Mechanism

The reaction proceeds via a stepwise [3+2] cycloaddition. The base deprotonates TosMIC, generating a carbanion that attacks the aldehyde carbonyl. The resulting intermediate cyclizes to form an oxazoline, which then eliminates p-toluenesulfinic acid (TosH) to aromatize into the oxazole.^[2]

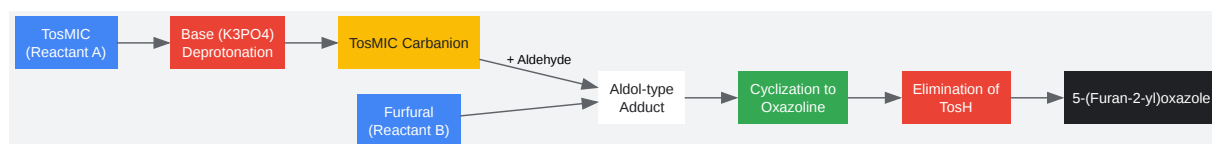

[Click to download full resolution via product page](#)

Figure 1: Mechanistic pathway of the Van Leusen oxazole synthesis.

Experimental Reagents

- Substrate: Furan-2-carboxaldehyde (1.0 equiv, 1.0 mmol)
- Reagent: p-Toluenesulfonylmethyl isocyanide (TosMIC) (1.0 equiv, 1.0 mmol)
- Base: Potassium Phosphate () (2.0 equiv)^[3]
 - Note: Using 1.0 equiv often arrests the reaction at the oxazoline stage. 2.0 equiv ensures full aromatization.
- Solvent: Isopropanol (IPA) (10 mL)
 - Why IPA? It has a high loss tangent (), ensuring efficient microwave absorption at 2450 MHz.

Step-by-Step Procedure

- Setup: In a 30 mL microwave process vial, dissolve Furan-2-carboxaldehyde (96 mg, 1 mmol) and TosMIC (195 mg, 1 mmol) in 10 mL of Isopropanol.
- Activation: Add (424 mg, 2 mmol) to the solution. Cap the vial with a Teflon-lined septum.
- Irradiation: Place the vial in the microwave reactor.
 - Mode: Dynamic Power (maintains constant temp).
 - Temperature: 60°C.
 - Power Max: 280 W.
 - Time: 8 minutes.

- Stirring: High (magnetic stir bar).
- Workup:
 - Cool the mixture to room temperature (using compressed air flow in the reactor).
 - Pour the reaction mixture into ice-cold water (30 mL).
 - Extract with Ethyl Acetate (mL).
 - Wash combined organic layers with brine, dry over , and concentrate in vacuo.
- Purification: The crude product is often pure enough (>90%). If necessary, purify via silica gel flash chromatography (Hexane:EtOAc 8:2).

Protocol B: Modified Ortoleva-King Synthesis

Target: 4-(Furan-2-yl)oxazol-2-amine derivatives. Mechanism: Oxidative condensation of ketones with urea.

Experimental Reagents

- Substrate: 2-Acetylfuran (1.0 equiv, 0.90 mmol)
- Reagent: Urea (1.0 equiv, 0.90 mmol)
- Oxidant: Iodine () (1.0 equiv)
 - Note: While some recent "green" papers omit iodine, the stoichiometry requires an oxidant to remove hydrogen. Iodine is the standard for high reliability.
- Solvent: Ethanol (1.0 mL)

Step-by-Step Procedure

- Setup: Mix 2-Acetylfuran (100 mg), Urea (54 mg), and Iodine (228 mg) in a 10 mL microwave vial.
- Solvent: Add 1.0 mL of Ethanol.
- Irradiation:
 - Temperature: 100–120°C.[4]
 - Power: 750 W (Max).[4][5]
 - Time: 1–2 minutes.
- Workup:
 - Cool to room temperature.[2][6][7]
 - Quench with aqueous Sodium Thiosulfate () to remove excess iodine.
 - Basify with Ammonium Hydroxide () to precipitate the product.
 - Filter the solid and recrystallize from ethanol.[4][5][6][7]

Data Analysis & Validation

Yield Comparison: Microwave vs. Conventional

The following data highlights the efficiency gains using Protocol A (Van Leusen) and Protocol B (Urea Condensation).

Entry	Reaction Type	Substrate	Method	Time	Yield (%)
1	Van Leusen	Furfural	Microwave (60°C)	8 min	96%
2	Van Leusen	Furfural	Thermal Reflux	6 hours	81%
3	Urea Condensation	2-Acetylfuran	Microwave (120°C)	1 min	92%
4	Urea Condensation	2-Acetylfuran	Thermal Reflux	4 hours	65%

Troubleshooting Guide

- Low Yield (Protocol A): Ensure

 is finely ground. Large particles reduce surface area for the heterogeneous reaction.
- Incomplete Cyclization (Protocol A): If oxazoline intermediate is observed (via NMR), increase reaction time to 12 minutes or increase temperature to 70°C.
- Charring (Protocol B): Furan rings are acid-sensitive. Ensure the reaction time does not exceed 2 minutes at 750W.

Workflow Visualization

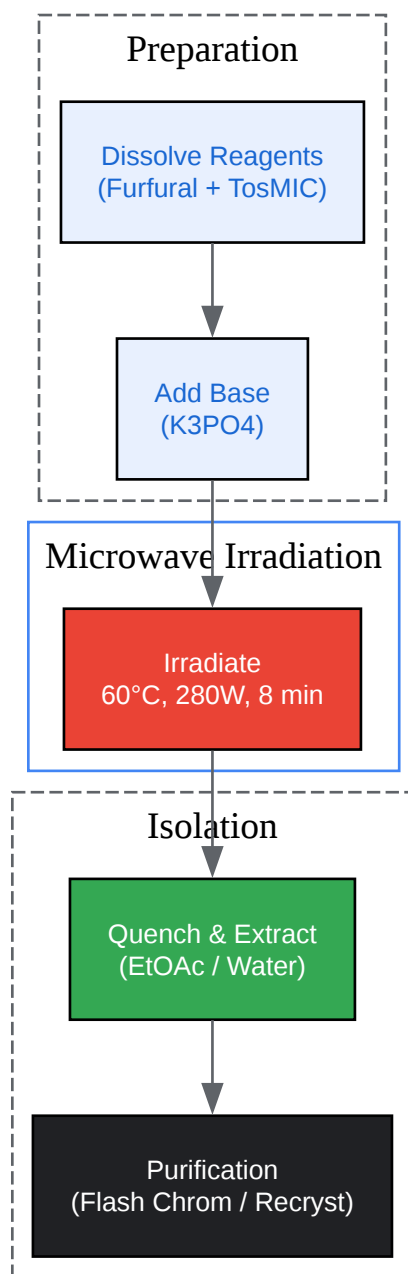

[Click to download full resolution via product page](#)

Figure 2: Operational workflow for the microwave-assisted synthesis of furan-oxazole derivatives.

References

- Sabale, K.P., & Kakade, G.K. (2026). Microwave-Assisted Reaction Optimization and Synthesis of Novel N-Ethylidene-4-(Furan-2-yl) Oxazol-2-Amine Derivatives. Asian Journal of

Green Chemistry, 10(1), 165-180. [Link](#)

- Mukku, N., Davanagere, P.M., & Maiti, B. (2020). A Facile Microwave-Assisted Synthesis of Oxazoles and Diastereoselective Oxazolines Using Aryl-Aldehydes, p-Toluenesulfonylmethyl Isocyanide under Controlled Basic Conditions. ACS Omega, 5(43), 28191–28200. [Link](#)
- Khan, K.M., et al. (2004). Microwave-Assisted Synthesis of 2,5-Disubstituted-1,3,4-Oxadiazoles.[8] Letters in Organic Chemistry, 1(1), 50-52.[8] [Link](#)
- Joshi, S., Bisht, A.S., & Juyal, D. (2017). Systematic scientific study of 1, 3-oxazole derivatives as a useful lead for pharmaceuticals: A review. The Pharma Innovation Journal, 6(1), 109-114. [Link](#)

Need Custom Synthesis?

BenchChem offers custom synthesis for rare earth carbides and specific isotopic labeling.

Email: info@benchchem.com or [Request Quote Online](#).

Sources

- 1. revroum.lew.ro [revroum.lew.ro]
- 2. ijpsonline.com [ijpsonline.com]
- 3. A Facile Microwave-Assisted Synthesis of Oxazoles and Diastereoselective Oxazolines Using Aryl-Aldehydes, p-Toluenesulfonylmethyl Isocyanide under Controlled Basic Conditions - PMC [pmc.ncbi.nlm.nih.gov]
- 4. researchgate.net [researchgate.net]
- 5. ajgreenchem.com [ajgreenchem.com]
- 6. Microwave-assisted synthesis of some 1H-1,2,4-triazol-3-one derivatives [scielo.org.za]
- 7. Microwave-assisted synthesis of some 1H-1,2,4-triazol-3-one derivatives [scielo.org.za]
- 8. researchgate.net [researchgate.net]
- To cite this document: BenchChem. [Application Note: Microwave-Assisted Synthesis of Furan-Oxazole Derivatives]. BenchChem, [2026]. [Online PDF]. Available at: [<https://www.benchchem.com/product/b3360088/docs#application-note-microwave-assisted-synthesis-of-furan-oxazole-derivatives>]

Disclaimer & Data Validity:

The information provided in this document is for Research Use Only (RUO) and is strictly not intended for diagnostic or therapeutic procedures. While BenchChem strives to provide accurate protocols, we make no warranties, express or implied, regarding the fitness of this product for every specific experimental setup.

Technical Support: The protocols provided are for reference purposes. Unsure if this reagent suits your experiment?

Need Industrial/Bulk Grade? [Request Custom Synthesis Quote](#)

BenchChem

Our mission is to be the trusted global source of essential and advanced chemicals, empowering scientists and researchers to drive progress in science and industry.

Contact

Address: 3281 E Guasti Rd
Ontario, CA 91761, United States
Phone: (601) 213-4426
Email: info@benchchem.com

[Contact our Ph.D. Support Team for a compatibility check](#)