

Application Note: Precision Synthesis of 9-(2-Hydroxyethyl)adenine (9-HEA)

Author: BenchChem Technical Support Team. **Date:** April 2026

Compound of Interest

Compound Name: 2-(2-Aminopurin-9-yl)ethanol

CAS No.: 7471-56-9

Cat. No.: B3357709

[Get Quote](#)

Abstract

9-(2-Hydroxyethyl)adenine (9-HEA) is a critical pharmacophore in the synthesis of acyclic nucleoside phosphonate antivirals (e.g., Adefovir, Tenofovir analogs) and a versatile monomer for Peptide Nucleic Acid (PNA) backbones. Traditional alkylation of adenine using 2-chloroethanol often suffers from poor regioselectivity, yielding significant N7-isomer impurities and requiring tedious chromatographic separation. This protocol details a robust, scalable, and highly regioselective synthesis of 9-HEA using ethylene carbonate (EC) in the presence of a catalytic base. The method prioritizes atom economy, safety (avoiding volatile alkyl halides), and purification efficiency via crystallization, ensuring high purity (>98%) suitable for downstream pharmaceutical applications.

Introduction & Mechanistic Rationale

The Regioselectivity Challenge

Adenine possesses multiple nucleophilic sites, primarily N9, N7, and the exocyclic N6-amine. Under standard alkylation conditions (e.g., alkyl halides + base), the N9-isomer is

thermodynamically preferred, but kinetic control often leads to N7-alkylation (up to 20-30%) and N3-alkylation.

The Ethylene Carbonate Advantage

This protocol utilizes Ethylene Carbonate (EC) as a "masked" hydroxyethylating agent. The reaction proceeds via nucleophilic attack of the adeninyl anion on the alkylene carbon of EC, followed by decarboxylation.

- **Selectivity:** The steric bulk and mechanism of EC ring-opening, combined with thermodynamic control at elevated temperatures (130–140°C), strongly favor the N9-isomer.
- **Safety:** EC is a non-volatile, low-toxicity solid, replacing hazardous alkylating agents like 2-bromoethanol or ethylene oxide.
- **Atom Economy:** The only byproduct is CO₂, simplifying workup.

Reaction Pathway Diagram

The following diagram illustrates the reaction pathway and the critical divergence between N9 and N7 alkylation.

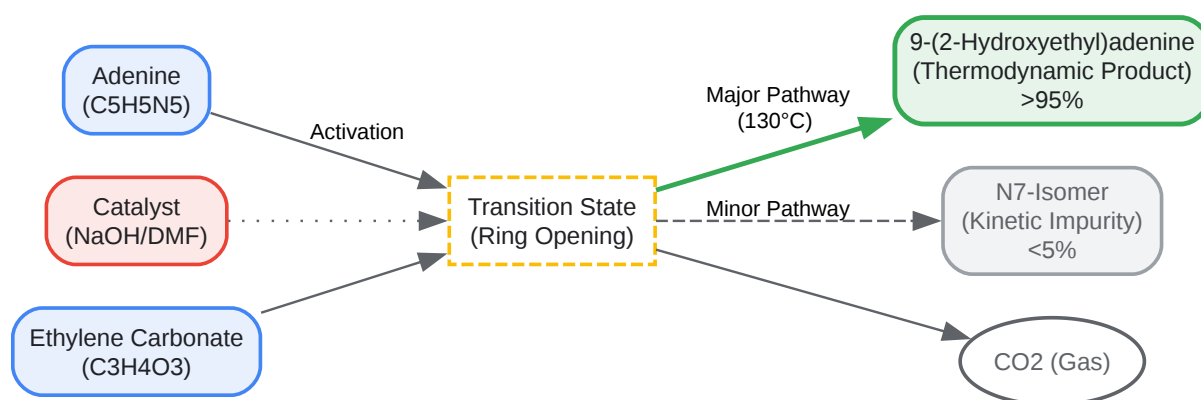

[Click to download full resolution via product page](#)

Caption: Mechanistic pathway of Adenine hydroxyethylation via Ethylene Carbonate. High temperature favors the thermodynamic N9 product.

Experimental Protocol

Materials & Equipment

- Reagents:
 - Adenine (Purity >98%)[1][2]
 - Ethylene Carbonate (EC) (Solid, MP ~36°C)
 - Sodium Hydroxide (NaOH) (Pellets or powder)
 - N,N-Dimethylformamide (DMF) (Anhydrous preferred)
 - Ethanol (Absolute, for recrystallization)
- Equipment:
 - Round-bottom flask (250 mL) with magnetic stir bar.
 - Reflux condenser.
 - Oil bath with temperature controller.
 - Vacuum filtration setup.

Step-by-Step Methodology

Phase 1: Reaction Setup

- Charge: In a 250 mL round-bottom flask, suspend Adenine (10.0 g, 74.0 mmol) in DMF (50 mL).
- Catalyst Addition: Add NaOH (0.30 g, 7.5 mmol, ~10 mol%).
 - Note: A catalytic amount of base is sufficient to generate the nucleophilic adeninyl anion. Excess base can lead to side reactions or difficult purification.
- Reagent Addition: Add Ethylene Carbonate (7.2 g, 81.4 mmol, 1.1 equiv).

- Optimization Tip: A slight excess of EC ensures complete consumption of Adenine.

Phase 2: Reaction & Monitoring

- Heating: Heat the mixture to 130–140°C with vigorous stirring.
 - Observation: The suspension will gradually clear as Adenine reacts and the product dissolves. CO₂ evolution may be observed as bubbling.
- Duration: Maintain temperature for 4–6 hours.
- Monitoring: Monitor reaction progress via TLC (System: 15% MeOH in DCM).
 - Adenine Rf: ~0.3^{[3][4]}
 - 9-HEA Rf: ~0.5^{[2][3][4]}
 - Endpoint: Disappearance of the Adenine spot.

Phase 3: Workup & Isolation

- Cooling: Allow the reaction mixture to cool to room temperature.
 - Precipitation: The product may spontaneously crystallize upon cooling.
- Quenching: If no precipitate forms, cool to 0°C and dilute slowly with cold Ethanol (50 mL) or Water (20 mL) to induce crystallization.
- Filtration: Filter the crude solid under vacuum. Wash the cake with cold ethanol (2 x 15 mL) to remove residual DMF and unreacted EC.

Phase 4: Purification (Self-Validating Step)

- Recrystallization: Transfer the crude solid to a clean flask.
 - Add Water (approx. 10-15 mL per gram of solid).
 - Heat to boiling until fully dissolved.
 - Optional: Add activated charcoal (1% w/w), stir for 5 mins, and filter hot to remove color.

- Allow the filtrate to cool slowly to room temperature, then to 4°C overnight.
- Final Isolation: Collect the white needle-like crystals by filtration. Dry in a vacuum oven at 60°C for 12 hours.

Workflow Diagram

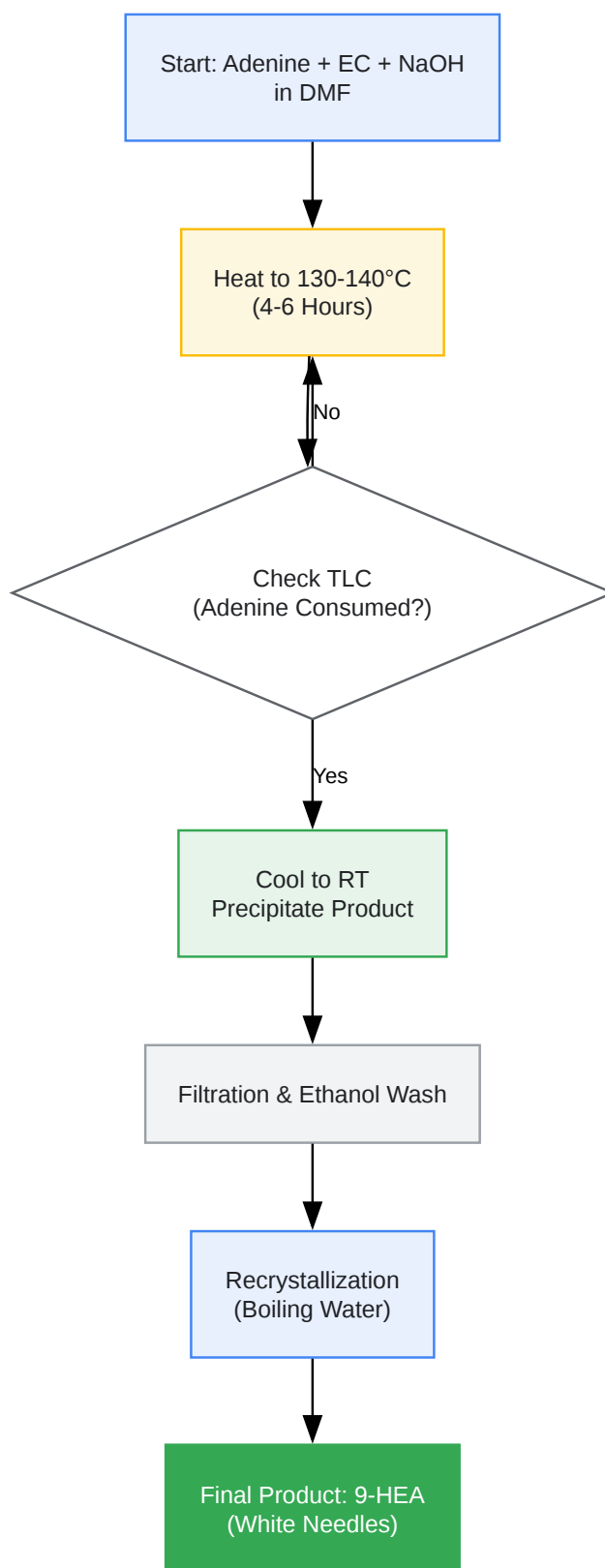

[Click to download full resolution via product page](#)

Caption: Operational workflow for the synthesis and purification of 9-HEA.

Analytical Validation & Specifications

To ensure the integrity of the synthesized compound, the following analytical benchmarks must be met. The melting point is a critical indicator of N9 vs N7 purity, as the N7 isomer typically lowers the melting range.

Quantitative Data Summary

Parameter	Specification	Notes
Appearance	White crystalline needles	Yellowing indicates oxidation or residual solvent.
Yield	60 – 75%	Lower yields may indicate incomplete precipitation.
Melting Point	238 – 242°C	Lit: 238-239°C. Sharp range indicates high purity.
HPLC Purity	> 98.0%	Column: C18, Mobile Phase: Water/MeOH gradient.
Regioselectivity	> 99:1 (N9:N7)	Confirmed by NMR (C8-H shift).

NMR Characterization (DMSO-d6)

The following chemical shifts are diagnostic for 9-HEA. The position of the alkyl chain signals confirms N9 substitution.[4]

- ¹H NMR (500 MHz, DMSO-d6):
 - δ 8.13 (s, 1H, H-2 or H-8)
 - δ 8.07 (s, 1H, H-8 or H-2)[5]
 - δ 7.18 (s, 2H, NH₂, exchangeable)[5]
 - δ 5.02 (t, J=5.3 Hz, 1H, OH, exchangeable)[5]
 - δ 4.18 (t, J=5.6 Hz, 2H, N9-CH₂)

- δ 3.73 (q, J=5.4 Hz, 2H, CH₂-OH)
- Interpretation: The triplet at 4.18 ppm corresponds to the methylene group attached to the nitrogen. In N7-isomers, this peak typically shifts downfield or exhibits different splitting patterns due to the proximity to the N6-amine.

Troubleshooting & Critical Control Points

Issue	Probable Cause	Corrective Action
Low Yield	Product lost in mother liquor during crystallization.	Concentrate the mother liquor and perform a second crop crystallization. Ensure water volume is minimized (10-15 mL/g).
Low Melting Point (<235°C)	Presence of N7-isomer or residual EC.	Recrystallize again from boiling water. N7-isomer is more soluble in water and remains in the filtrate.
Incomplete Reaction	Temperature too low or insufficient catalyst.	Ensure oil bath is >130°C. Add an additional 0.1 eq of NaOH if reaction stalls.
Coloration (Brown/Yellow)	Thermal decomposition of DMF or Adenine.	Degas DMF prior to use. Maintain inert atmosphere (N ₂) if possible. Use activated charcoal during recrystallization.

References

- Holy, A. (1987). Preparation of 9-(2-phosphonomethoxyethyl)adenine esters as potential prodrugs. Collection of Czechoslovak Chemical Communications. [Link](#) (Foundational methodology for PMEAs precursors).
- Gilead Sciences, Inc. (1999). Process Optimization in the Synthesis of 9-[2-(Diethylphosphonomethoxy)ethyl]adenine. ACS Publications.[6] [Link](#) (Industrial optimization)

of adenine alkylation).

- Sigma-Aldrich.9-(2-Hydroxyethyl)adenine Product Specification. [Link](#) (Physical property verification).
- ResearchGate.Structure of 9-(2'-hydroxyethyl)adenine and NMR data. [Link](#) (Spectral data confirmation).
- TCI Chemicals.9-(2-Hydroxyethyl)adenine Safety Data Sheet. [Link](#) (Safety and handling protocols).

Need Custom Synthesis?

BenchChem offers custom synthesis for rare earth carbides and specific isotopic labeling.

Email: info@benchchem.com or [Request Quote Online](#).

Sources

- 1. 9-(2-Hydroxyethyl)adenine , >98.0%(HPLC) , 707-99-3 - CookeChem [cookechem.com]
- 2. CN104530129A - Method for preparing (R)-9-(2-phosphomethoxypropyl)adenine - Google Patents [patents.google.com]
- 3. CN103709164A - Synthetic method for adenine - Google Patents [patents.google.com]
- 4. researchgate.net [researchgate.net]
- 5. researchgate.net [researchgate.net]
- 6. pubs.acs.org [pubs.acs.org]
- To cite this document: BenchChem. [Application Note: Precision Synthesis of 9-(2-Hydroxyethyl)adenine (9-HEA)]. BenchChem, [2026]. [Online PDF]. Available at: [<https://www.benchchem.com/product/b3357709/docs#application-note-precision-synthesis-of-9-2-hydroxyethyl-adenine-9-hea>]

Disclaimer & Data Validity:

The information provided in this document is for Research Use Only (RUO) and is strictly not intended for diagnostic or therapeutic procedures. While BenchChem strives to provide

accurate protocols, we make no warranties, express or implied, regarding the fitness of this product for every specific experimental setup.

Technical Support: The protocols provided are for reference purposes. Unsure if this reagent suits your experiment?

Need Industrial/Bulk Grade? [Request Custom Synthesis Quote](#)

BenchChem

Our mission is to be the trusted global source of essential and advanced chemicals, empowering scientists and researchers to drive progress in science and industry.

Contact

Address: 3281 E Guasti Rd

Ontario, CA 91761, United States

Phone: (601) 213-4426

Email: info@benchchem.com

[Contact our Ph.D. Support Team for a compatibility check](#)