

Thermodynamic Stability and Reactivity of N-Acyl Pyrazole Derivatives

Author: BenchChem Technical Support Team. **Date:** April 2026

Compound of Interest

Compound Name: 1-(3-Methyl-1H-pyrazol-1-yl)ethan-1-one
CAS No.: 69413-00-9
Cat. No.: B3356877

[Get Quote](#)

Executive Summary: The "Tunable" Amide

N-acyl pyrazoles occupy a critical "Goldilocks zone" in the landscape of activated amides. Unlike N-acyl imidazoles, which are often too moisture-sensitive for prolonged storage, or standard secondary amides, which are kinetically inert, N-acyl pyrazoles offer a programmable thermodynamic profile.

This guide details the physicochemical principles governing their stability. By manipulating the electronic and steric environment of the pyrazole ring, researchers can fine-tune the free energy of hydrolysis (

) and the activation energy (

) for acyl transfer. This "tunability" makes them indispensable for serine hydrolase inhibition, peptide synthesis, and prodrug design.

Mechanistic Underpinnings of Stability

The thermodynamic stability of N-acyl pyrazoles is governed by the competition for the nitrogen lone pair. In a standard amide, the nitrogen lone pair donates into the carbonyl

orbital, creating significant resonance stabilization (approx. 15-20 kcal/mol).

In N-acyl pyrazoles, this resonance is attenuated by two factors:

- **Aromatic Sequestration:** The nitrogen lone pair is part of the pyrazole aromatic system (specifically N1), reducing its availability for amide resonance.
- **Lone Pair Repulsion:** The proximity of the N2 lone pair to the carbonyl oxygen creates dipolar repulsion, often forcing the carbonyl out of coplanarity with the pyrazole ring.

The Hammett Correlation

The hydrolytic stability correlates linearly with the acidity of the conjugate acid of the leaving group (the pyrazole).

- **Electron-Withdrawing Groups (EWGs):** Substituents like 4-NO₂ or 4-CN decrease the reactivity of the pyrazole (making it a better leaving group), thereby destabilizing the N-acyl bond and increasing reactivity.
- **Electron-Donating Groups (EDGs):** Substituents like 3,5-dimethyl increase the reactivity of the pyrazole and steric bulk, significantly stabilizing the N-acyl bond against hydrolysis.

Hydrolytic Degradation Pathways

The primary thermodynamic instability of N-acyl pyrazoles manifests as hydrolysis. This follows a

base-catalyzed mechanism (Base-catalyzed, Acyl-oxygen cleavage, Bimolecular).

Mechanism Visualization

The following diagram illustrates the nucleophilic attack and the transition states involved in the degradation of N-acyl pyrazoles in aqueous media.

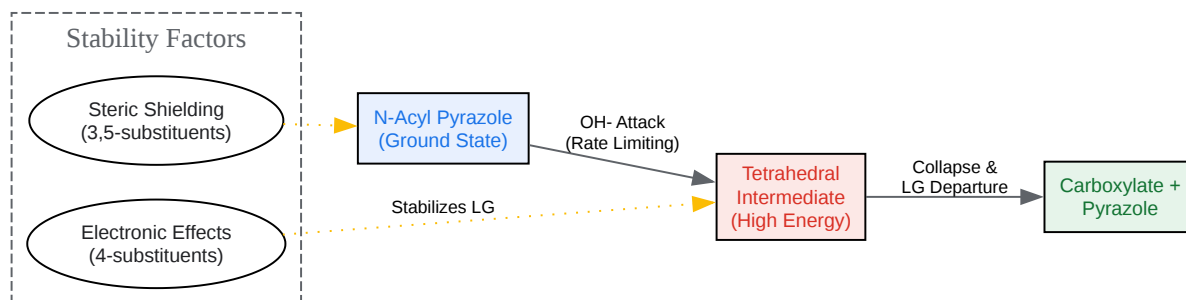

[Click to download full resolution via product page](#)

Caption: Figure 1. `ngcontent-ng-c2699131324="" _ngghost-ng-c2339441298="" class="inline ng-star-inserted">`

hydrolysis pathway. Steric bulk at positions 3 and 5 retards the initial

attack, while EWGs at position 4 stabilize the developing negative charge on the leaving group in the transition state.

Comparative Half-Life Data

The table below summarizes the stability of various N-acetyl pyrazoles in phosphate buffer (pH 7.4, 25°C).

Pyrazole Substituent	(Conj. Acid)	(Hydrolysis)	Reactivity Class
4-Nitro	~0.5	< 10 min	Highly Reactive (Acyl Transfer)
4-Cyano	~1.0	25 min	Reactive
Unsubstituted	2.5	4-6 hours	Moderate
3,5-Dimethyl	4.1	> 24 hours	Stable (Prodrug Potential)
3,5-Di-tert-butyl	~4.5	> 1 week	Hyper-Stable

Regiostability and Isomerization

A critical but often overlooked aspect of thermodynamic stability is acyl migration. In unsymmetrically substituted pyrazoles (e.g., 3-methylpyrazole), acylation can occur at N1 or N2.

- **Kinetic Product:** Acylation often occurs at the less sterically hindered nitrogen (N1 adjacent to the hydrogen/smaller group).
- **Thermodynamic Product:** Over time or under thermal stress, the acyl group may migrate to the nitrogen that allows for greater crystal lattice stability or reduced steric clash with the acyl group.

Note: In solution, intermolecular transacylation is the dominant mechanism for "isomerization." A sample of pure 1-acyl-3-methylpyrazole can equilibrate to a mixture of 1-acyl-3-methyl and 1-acyl-5-methyl isomers if traces of free pyrazole or acid/base catalysts are present.

Experimental Protocols

Protocol A: Determination of Hydrolytic Rate Constants ()

Purpose: To quantify the thermodynamic stability of a candidate N-acyl pyrazole in aqueous media.

Materials:

- UV-Vis Spectrophotometer (thermostatted to $25.0 \pm 0.1^\circ\text{C}$).
- Phosphate Buffer (50 mM, pH 7.4, ionic strength adjusted to 0.1 M with KCl).
- Stock solution of N-acyl pyrazole in Acetonitrile (MeCN).

Methodology:

- **Preparation:** Pre-incubate 2.97 mL of phosphate buffer in a quartz cuvette at 25°C for 10 minutes.

- Initiation: Rapidly inject 30 μL of the N-acyl pyrazole stock (final concentration $\sim 50\text{--}100\ \mu\text{M}$) into the cuvette. Invert to mix (dead time $< 5\text{s}$).
- Data Acquisition: Monitor the absorbance decay at the

of the N-acyl pyrazole (typically 230–260 nm). Note: Ensure the hydrolysis product (free pyrazole) does not have overlapping absorbance.
- Calculation: Fit the absorbance vs. time data to a pseudo-first-order exponential decay equation:
- Validation: Repeat at pH 6.0 and pH 8.0 to generate a pH-rate profile.

Protocol B: NMR Monitoring of Isomerization

Purpose: To detect 1,3- vs 1,5-acyl migration or degradation in organic solvents.

Methodology:

- Dissolve 10 mg of the N-acyl pyrazole in 0.6 mL of deuterated solvent (e.g.,

or

).
- Add an internal standard (e.g., 1,3,5-trimethoxybenzene) to normalize integration.
- Acquire a

-NMR spectrum.
- Store the tube at the desired temperature (e.g., RT or 40°C).
- Acquire spectra at defined intervals (1h, 24h, 48h).
- Analysis: Monitor the shift of the pyrazole ring protons. 1,5-isomers typically show distinct shielding patterns compared to 1,3-isomers due to the proximity of the acyl carbonyl to the substituent.

Strategic Applications Workflow

The following diagram outlines how to select an N-acyl pyrazole based on the required thermodynamic stability for specific applications.

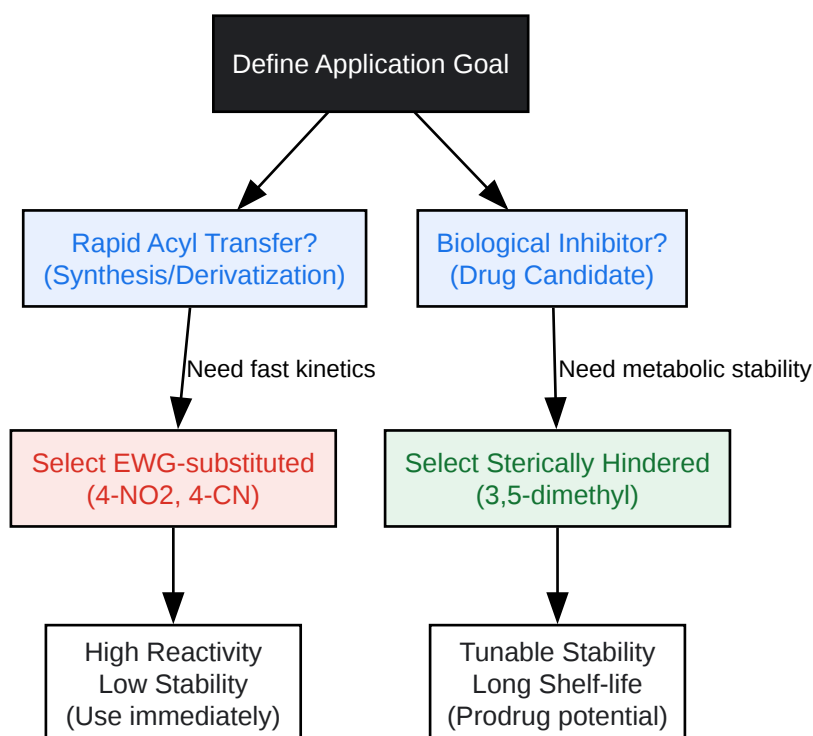

[Click to download full resolution via product page](#)

Caption: Figure 2. Decision matrix for selecting N-acyl pyrazole derivatives based on thermodynamic requirements.

References

- Vagstad, A. L., et al. (2023). "N-Acyl pyrazoles: effective and tunable inhibitors of serine hydrolases." National Institutes of Health. Available at: [\[Link\]](#)
- Leresche, J. E., et al. (2023). "Kinetics and Mechanism of Azole $n-\pi^*$ -Catalyzed Amine Acylation." ACS Publications. Available at: [\[Link\]](#)
- Katritzky, A. R. (2004).[1] "N-Acylation in Combinatorial Chemistry." Arkivoc. Available at: [\[Link\]](#)

- RSC Advances. (2025). "Eco-friendly methods for the synthesis of N-acyl pyrazole derivatives." Royal Society of Chemistry.[2] Available at: [\[Link\]](#)
- Denny, R. A., et al. (2023). "Structure-activity relationship and improved hydrolytic stability of pyrazole derivatives." Bioorganic & Medicinal Chemistry Letters. Available at: [\[Link\]](#)

Need Custom Synthesis?

BenchChem offers custom synthesis for rare earth carbides and specific isotopic labeling.

Email: info@benchchem.com or [Request Quote Online](#).

Sources

- 1. [researchgate.net \[researchgate.net\]](#)
- 2. [researchgate.net \[researchgate.net\]](#)
- To cite this document: BenchChem. [Thermodynamic Stability and Reactivity of N-Acyl Pyrazole Derivatives]. BenchChem, [2026]. [Online PDF]. Available at: [\[https://www.benchchem.com/product/b3356877/docs#thermodynamic-stability-and-reactivity-of-n-acyl-pyrazole-derivatives\]](https://www.benchchem.com/product/b3356877/docs#thermodynamic-stability-and-reactivity-of-n-acyl-pyrazole-derivatives)

Disclaimer & Data Validity:

The information provided in this document is for Research Use Only (RUO) and is strictly not intended for diagnostic or therapeutic procedures. While BenchChem strives to provide accurate protocols, we make no warranties, express or implied, regarding the fitness of this product for every specific experimental setup.

Technical Support: The protocols provided are for reference purposes. Unsure if this reagent suits your experiment?

Need Industrial/Bulk Grade? [Request Custom Synthesis Quote](#)

BenchChem

Our mission is to be the trusted global source of essential and advanced chemicals, empowering scientists and researchers to drive progress in science and industry.

Contact

Address: 3281 E Guasti Rd

Ontario, CA 91761, United States

Phone: (601) 213-4426

Email: info@benchchem.com

[Contact our Ph.D. Support Team for a compatibility check](#)