

# Mass Spectrometry Fragmentation Patterns of Methoxy Pyrroles

**Author:** BenchChem Technical Support Team. **Date:** May 2026

## Compound of Interest

Compound Name: 3-Methoxy-2-methyl-1H-pyrrole

CAS No.: 68332-40-1

Cat. No.: B3356728

[Get Quote](#)

Content Type: Publish Comparison Guide Audience: Researchers, Scientists, and Drug Development Professionals[1]

## Executive Summary: The Structural Elucidation Challenge

Methoxy pyrroles represent a critical structural motif in bioactive natural products (e.g., prodigiosins, lamellarins) and synthetic pharmaceutical candidates.[1] However, their mass spectrometric (MS) characterization presents a distinct challenge: distinguishing the methoxy group (-OCH<sub>3</sub>) from isomeric hydroxymethyl (-CH<sub>2</sub>OH) or N-oxide functionalities.[1]

This guide provides a comparative technical analysis of methoxy pyrrole fragmentation patterns against these isomeric alternatives. By leveraging specific diagnostic ions and fragmentation mechanisms—specifically the "anisole-type" rearrangement and ring expansion phenomena—researchers can confidently assign structures without relying solely on NMR.[1]

## Comparative Analysis: Methoxy Pyrroles vs. Isomeric Alternatives

The following table contrasts the mass spectral behavior of 2-methoxy-pyrrole against its common isomers under Electron Ionization (EI) and Electrospray Ionization (ESI-MS/MS).

Table 1: Diagnostic Ion Comparison for Pyrrole Derivatives (MW ~97 Da)

Feature	Methoxy Pyrrole (-OCH <sub>3</sub> )	Hydroxymethyl Pyrrole (-CH <sub>2</sub> OH)	Methyl Pyrrole N-Oxide (N → O)
Primary Neutral Loss (EI)	[1]•CH <sub>3</sub> (15 Da) & CH <sub>2</sub> O (30 Da)	[1]•OH (17 Da) & H <sub>2</sub> O (18 Da)	[1]•O (16 Da)
Base Peak (Typical)	[M - CH <sub>3</sub> ] <sup>+</sup> or [M - CH <sub>2</sub> O] <sup>+</sup>	[M - OH] <sup>+</sup>	[M - O] <sup>+</sup>
Mechanism	Radical cleavage or CO extrusion rearrangement	Dehydration / Alpha-cleavage	N-O bond homolysis
Diagnostic Ratio	High [M-30]/[M-15] ratio indicates aromatic ether character.[1]	High [M-18] abundance suggests alcohol.[1]	Strong [M-16] indicates labile N-oxygen bond.[1]
Ring Expansion	Possible (Pyrrole → Pyridine intermediate)	Less common	Rare

“

*Expert Insight: The presence of a strong signal at [M-30] (Loss of Formaldehyde) is the "smoking gun" for methoxy-substituted aromatic rings, distinguishing them from hydroxymethyl isomers which favor water loss [1, 2].*[1]

## Deep Dive: Fragmentation Mechanics

To interpret the spectra accurately, one must understand the causality behind the peaks.[1] Methoxy pyrroles do not merely "break"; they undergo specific rearrangements that serve as self-validating structural checks.[1]

### Mechanism A: The "Anisole-Type" Rearrangement (Loss of CH<sub>2</sub>O)

Similar to anisole, C-methoxy pyrroles undergo a four-center rearrangement.[1] The methyl hydrogen migrates to the ring or oxygen, followed by the extrusion of neutral formaldehyde (CH<sub>2</sub>O).[1] This results in a stable distonic ion or a quinoid-type structure.[1]

### Mechanism B: Ring Expansion (Pyrrole → Pyridine)

Under high-energy conditions (EI or high collision energy CID), alkyl and alkoxy pyrroles can undergo ring expansion.[1] A methoxy-substituted pyrrole cation can rearrange into a pyridinium-like species before fragmentation.[1] This scrambling can sometimes obscure regioisomeric information (2-methoxy vs. 3-methoxy) but is characteristic of the pyrrole core [3, 4].[1]

## Visualization: Fragmentation Pathways

The following diagram illustrates the competing pathways for a generic 2-methoxy-pyrrole.

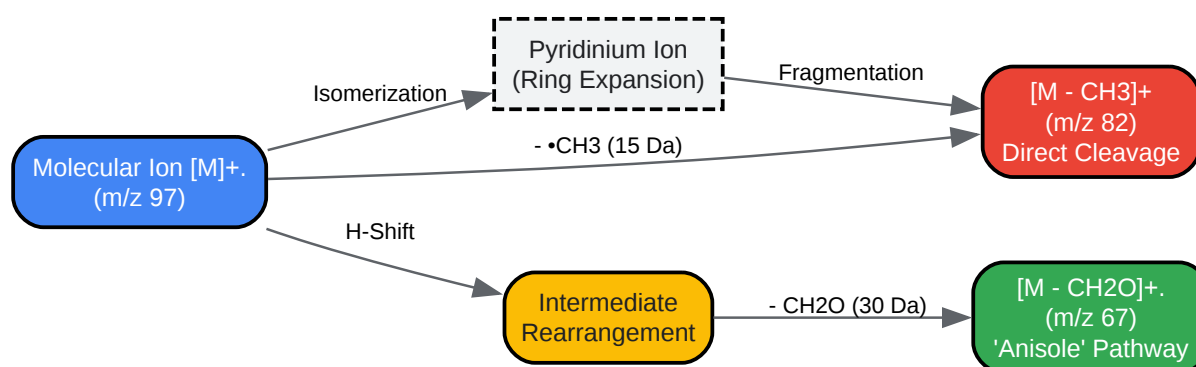

[Click to download full resolution via product page](#)

Figure 1: Competing fragmentation pathways for Methoxy Pyrroles.[1] The loss of CH<sub>2</sub>O (Green node) is the key differentiator from isomeric alcohols.[1]

## Experimental Protocol: Self-Validating Identification Workflow

This protocol ensures high-confidence identification using LC-MS/MS (ESI) or GC-MS (EI).[1]

Objective: Distinguish 2-methoxy-pyrrole derivatives from hydroxymethyl isomers.

### Step 1: Ionization Source Selection

- Use ESI (Positive Mode) for initial molecular weight confirmation ( ).[1]
- Use EI (70 eV) if the compound is volatile; EI provides a richer "fingerprint" for the ring expansion observation.[1]

### Step 2: MS/MS Collision Induced Dissociation (CID)[1]

- Isolate the precursor ion ( ).[1]
- Apply stepped Collision Energy (e.g., 10, 20, 40 eV).[1]
- Checkpoint: If the primary fragment is -18 Da ( ), suspect Hydroxymethyl.[1] If the primary fragment is -30/32 Da ( ), suspect Methoxy.[1]

### Step 3: Deuterium Exchange (The Validation Step)

- Dissolve sample in .[1]
- Hydroxymethyl (-CH<sub>2</sub>OH): The hydroxyl proton exchanges, shifting the mass by +1 Da.[1]
- Methoxy (-OCH<sub>3</sub>): No exchange occurs (Mass remains M).[1]

- Causality: This confirms the presence/absence of labile protons, validating the MS interpretation.[1]

## Decision Tree for Analysts

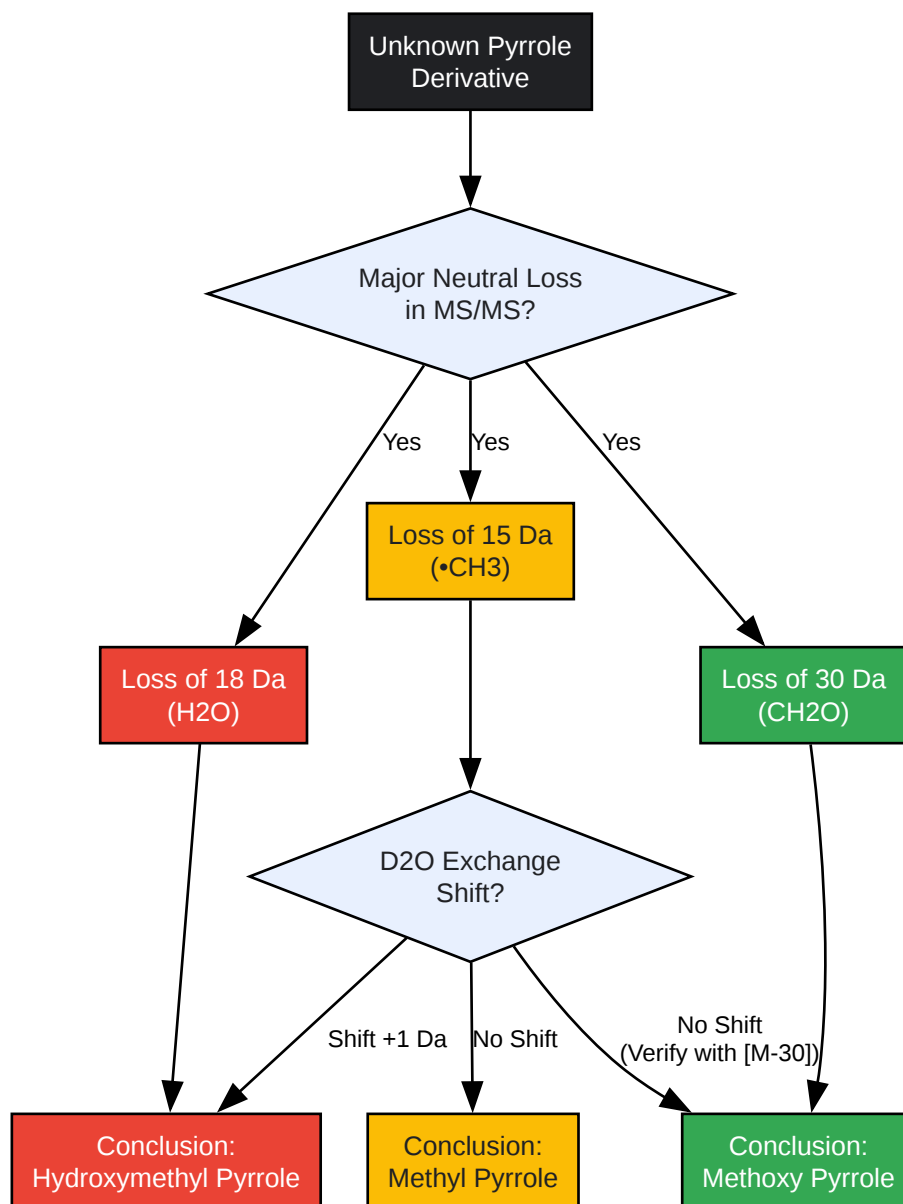

[Click to download full resolution via product page](#)

Figure 2: Logical workflow for distinguishing pyrrole isomers using MS data.

## References

- BenchChem. (2025).[1][2][3] Mass Spectrometry of Alkylated Pyrrole Derivatives: An In-depth Technical Guide. Retrieved from [1]
- Liang, X., Guo, Z., & Yu, C. (2013).[1] Fragmentation pathways of 2-substituted pyrrole derivatives using electrospray ionization ion trap and electrospray ionization quadrupole time-of-flight mass spectrometry. Rapid Communications in Mass Spectrometry. Retrieved from
- Trevitt, A., et al. (2025).[1] Direct detection of pyridine formation by the reaction of CH with pyrrole: A ring expansion reaction. ResearchGate. Retrieved from
- Amarnath, V., et al. (1994).[1][4] The mechanism of nucleophilic substitution of alkylpyrroles in the presence of oxygen. Chemical Research in Toxicology. Retrieved from [1]

### Need Custom Synthesis?

BenchChem offers custom synthesis for rare earth carbides and specific isotopic labeling.

Email: [info@benchchem.com](mailto:info@benchchem.com) or [Request Quote Online](#).

## Sources

- [1. livesciencesite.com \[livesciencesite.com\]](https://livesciencesite.com)
- [2. pdf.benchchem.com \[pdf.benchchem.com\]](https://pdf.benchchem.com)
- [3. pdf.benchchem.com \[pdf.benchchem.com\]](https://pdf.benchchem.com)
- [4. The mechanism of nucleophilic substitution of alkylpyrroles in the presence of oxygen - PubMed \[pubmed.ncbi.nlm.nih.gov\]](https://pubmed.ncbi.nlm.nih.gov)
- To cite this document: BenchChem. [Mass Spectrometry Fragmentation Patterns of Methoxy Pyrroles]. BenchChem, [2026]. [Online PDF]. Available at: [\[https://www.benchchem.com/product/b3356728/docs#mass-spectrometry-fragmentation-patterns-of-methoxy-pyrroles\]](https://www.benchchem.com/product/b3356728/docs#mass-spectrometry-fragmentation-patterns-of-methoxy-pyrroles)

---

### Disclaimer & Data Validity:

The information provided in this document is for Research Use Only (RUO) and is strictly not intended for diagnostic or therapeutic procedures. While BenchChem strives to provide

accurate protocols, we make no warranties, express or implied, regarding the fitness of this product for every specific experimental setup.

**Technical Support:** The protocols provided are for reference purposes. Unsure if this reagent suits your experiment?

**Need Industrial/Bulk Grade?** [Request Custom Synthesis Quote](#)

## BenchChem

Our mission is to be the trusted global source of essential and advanced chemicals, empowering scientists and researchers to drive progress in science and industry.

### Contact

Address: 3281 E Guasti Rd

Ontario, CA 91761, United States

Phone: (601) 213-4426

Email: [info@benchchem.com](mailto:info@benchchem.com)

[Contact our Ph.D. Support Team for a compatibility check](#)