

# controlling phase purity in Cd(II)-H<sub>3</sub>IDC coordination polymers

**Author:** BenchChem Technical Support Team. **Date:** April 2026

## Compound of Interest

Compound Name: 2,3-dihydro-1H-imidazole-4,5-dicarboxylic Acid

CAS No.: 610265-04-8

Cat. No.: B3354744

[Get Quote](#)

## Technical Support Center: Cd(II)-H<sub>3</sub>IDC Coordination Polymers

Topic: Controlling Phase Purity & Structural Topology Applicable Systems: Cd(II) / 4,5-Imidazoledicarboxylic Acid (H<sub>3</sub>IDC) User Level: Advanced (Research & Development)

### Core Technical Overview: The Phase Selection Mechanism

The Cd(II)-H<sub>3</sub>IDC system is a classic example of pH-dependent supramolecular isomerism. The ligand H<sub>3</sub>IDC ( $pK_{a1} \approx 3.6$ ,  $pK_{a2} \approx 5.6$ ,  $pK_{a3} \approx 10.5$ ) acts as a "structural switch." Controlling the deprotonation state of the imidazole and carboxylic acid groups dictates the final dimensionality of the coordination polymer (CP).<sup>[1]</sup>

- H<sub>2</sub>IDC<sup>-</sup> (Mono-deprotonated): Favors 1D chains or discrete 0D complexes.
- H<sub>1</sub>IDC<sup>2-</sup> (Di-deprotonated): Favors 2D layered networks (often with H-bonding interlayers).

- IDC<sup>3-</sup> (Fully deprotonated): Favors 3D porous frameworks (MOF-like topologies).

## Phase Evolution Pathway

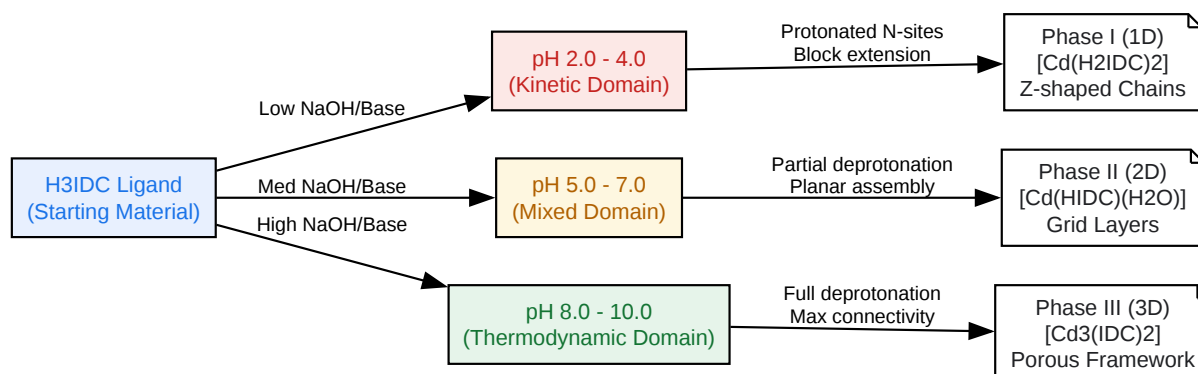

[Click to download full resolution via product page](#)

Figure 1: The pH-driven structural evolution of Cd(II)-H<sub>3</sub>IDC coordination polymers.

## Troubleshooting & FAQs

### Category A: Synthesis Failures (Precipitates vs. Crystals)

Q: I am getting a rapid white precipitate instead of single crystals. How do I slow down the nucleation? A: Rapid precipitation indicates the reaction kinetics are too fast, often due to high local concentration of the deprotonated ligand.

- **Solution 1 (pH Modulation):** Do not add base (NaOH/TEA) directly to the metal solution. Instead, use in-situ hydrolysis. Add urea or DMF decomposition (at >120°C) to slowly raise the pH over hours.
- **Solution 2 (Solvent Diffusion):** Use a layering technique. Dissolve Cd(NO<sub>3</sub>)<sub>2</sub> in water (bottom layer) and H<sub>3</sub>IDC in DMF/Ethanol (top layer). Separate with a buffer layer of pure solvent.

Q: The product contains a mixture of clear block crystals and needle-like crystals. How do I isolate the pure phase? A: This is a classic "concomitant polymorphism" issue.

- **Diagnosis:** The reaction conditions (likely Temperature or pH) are near the phase boundary between the kinetic product (needles, usually lower density) and thermodynamic product (blocks, higher density).
- **Fix:**
  - **Temperature:** Increase the solvothermal temperature by 20°C. Higher energy favors the thermodynamic phase (usually the 3D framework).
  - **Time:** Extend the reaction time from 24h to 72h to allow "Ostwald ripening," where the less stable phase redissolves and feeds the growth of the stable phase.

## Category B: Structural Defects & Porosity

Q: My 3D framework (Phase III) collapses upon solvent removal. How do I activate it without structural degradation? A: Cd(II)-H<sub>3</sub>IDC frameworks often rely on solvent molecules (Guest H<sub>2</sub>O/DMF) for structural integrity. Direct heating causes collapse.

- **Protocol:** Perform Supercritical CO<sub>2</sub> Drying or Solvent Exchange.
  - Soak crystals in volatile solvent (Acetone/Methanol) for 3 days, refreshing solvent every 12h.
  - Vacuum dry at room temperature first, then slowly ramp to 100°C.

## Experimental Protocols

### Protocol A: Synthesis of 3D Porous Framework [Cd<sub>3</sub>(IDC)<sub>2</sub>] (Thermodynamic Phase)

Target: High-connectivity framework for gas adsorption studies.

Reagents:

- Cd(NO<sub>3</sub>)<sub>2</sub>·2H<sub>2</sub>O (0.1 mmol)
- H<sub>3</sub>IDC (0.1 mmol)

- Solvent: DMF/H<sub>2</sub>O (1:1 v/v, 10 mL)
- Base: NaOH (0.1 M, 200 μL) – Crucial for IDC<sup>3-</sup> generation

#### Step-by-Step:

- Dissolution: Dissolve H<sub>3</sub>IDC in the DMF/H<sub>2</sub>O mixture. Sonicate until clear.
- pH Adjustment: Add NaOH dropwise. Target initial pH of 8.5.
- Metal Addition: Add Cd salt. Stir for 30 mins.
- Thermal Treatment: Seal in a 25 mL Teflon-lined autoclave.
  - Heat to 160°C for 72 hours. (High temp/long time favors 3D phase).
  - Cooling: Slow cool at 5°C/hour to room temperature (Critical for crystal size).
- Harvest: Wash colorless block crystals with DMF.

## Protocol B: Synthesis of 1D Chain [Cd(H<sub>2</sub>IDC)<sub>2</sub>] (Kinetic Phase)

Target: Proton-conductive materials or luminescent sensors.

#### Reagents:

- Cd(Cl)<sub>2</sub>·2.5H<sub>2</sub>O (0.1 mmol)
- H<sub>3</sub>IDC (0.2 mmol) – Excess ligand promotes lower connectivity
- Solvent: H<sub>2</sub>O/Ethanol (4:1 v/v)
- Acid: Dilute HCl (if necessary)

#### Step-by-Step:

- Dissolution: Mix reagents in water/ethanol.

- pH Control: Measure pH. If >4.0, add drops of 0.1M HCl to reach pH 3.0.
- Thermal Treatment: Seal in autoclave.
  - Heat to 100°C for 24 hours. (Lower temp/shorter time favors kinetic phase).
- Harvest: Filter needle-shaped crystals immediately. Do not allow to stand in mother liquor for days (may convert to 2D/3D forms).

## Data & Validation

### Phase Identification Table

Use this table to validate your product using Powder X-Ray Diffraction (PXRD) and TGA.

Parameter	Phase I (1D Chain)	Phase II (2D Layer)	Phase III (3D Framework)
Dominant Species	H <sub>2</sub> IDC <sup>-</sup> (Protonated)	HIDC <sup>2-</sup> (Mixed)	IDC <sup>3-</sup> (Fully Deprotonated)
Synthesis pH	2.0 – 4.0	5.0 – 7.0	8.0 – 10.0
Crystal Morphology	Thin Needles	Plates / Sheets	Block / Polyhedral
Characteristic PXRD	Strong low-angle peaks (6-8° 2θ)	Mid-range peaks (10-15° 2θ)	Complex pattern, peaks <5° 2θ
Thermal Stability	Low (<200°C)	Moderate (250°C)	High (>350°C)
Fluorescence	Weak / Ligand-based	Moderate	Strong (LMCT enhanced)

### Decision Tree for Optimization

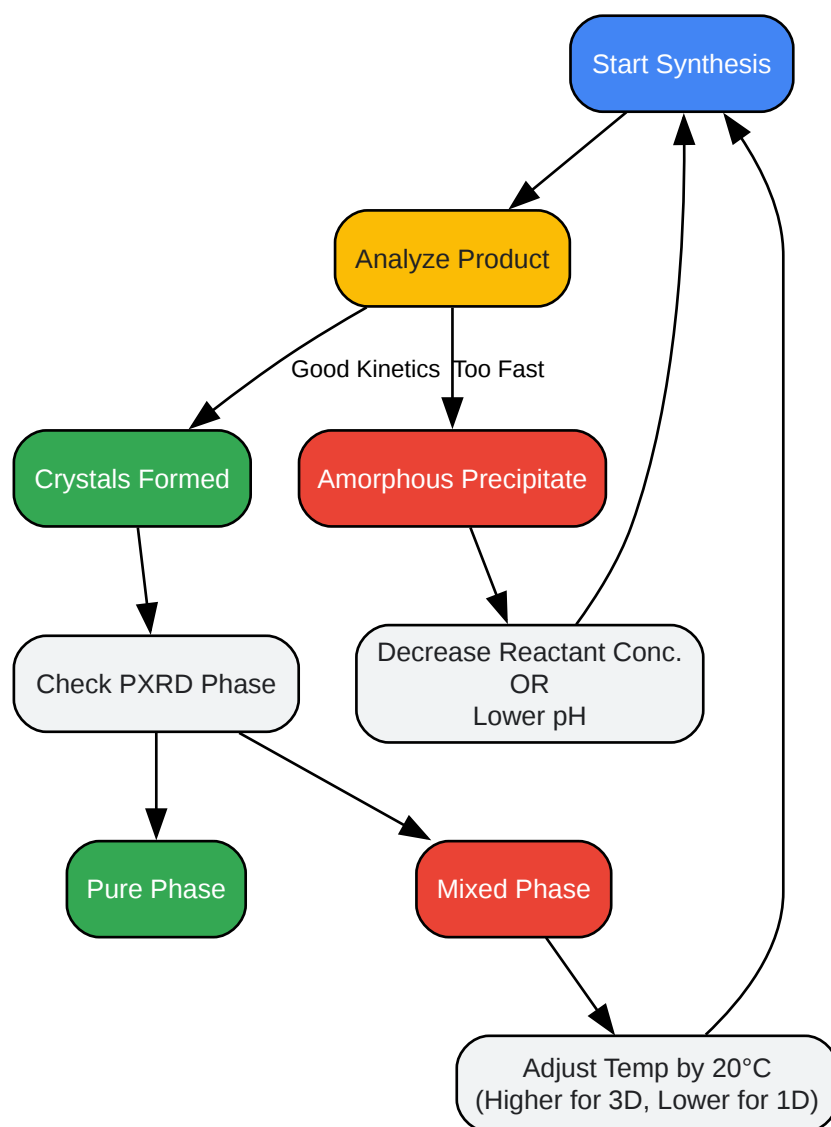

[Click to download full resolution via product page](#)

Figure 2: Troubleshooting logic for optimizing phase purity.

## References

- Structural Diversity and pH Dependence: Wang, Y., et al. "Structural Diversity of Cadmium(II) Coordination Polymers Induced by Tuning the Coordination Sites of Isomeric Ligands." *Inorganic Chemistry*, 2016.[3]
- H3IDC Ligand Chemistry: Dirersa, W. B.[1] "A Review on 4, 5-Imidazoledicarboxylic Acid: Their Chemistry and Coordination Potentials." [1][4] *Modern Chemistry & Applications*, 2017.

- Synthesis Protocols & Thermal Analysis: BenchChem Technical Support. "Comparing the coordination properties of different imidazole-4,5-dicarboxylic acid derivatives." BenchChem Protocols, 2025.[1][5]
- Kinetic vs. Thermodynamic Control: Jack Westin Academic Team. "Kinetic Control Versus Thermodynamic Control Of A Reaction." MCAT Chemistry Guide.

### Need Custom Synthesis?

BenchChem offers custom synthesis for rare earth carbides and specific isotopic labeling.

Email: [info@benchchem.com](mailto:info@benchchem.com) or [Request Quote Online](#).

## Sources

- 1. [pdf.benchchem.com](https://pdf.benchchem.com) [[pdf.benchchem.com](https://pdf.benchchem.com)]
- 2. [pubs.acs.org](https://pubs.acs.org) [[pubs.acs.org](https://pubs.acs.org)]
- 3. [chemistry.stackexchange.com](https://chemistry.stackexchange.com) [[chemistry.stackexchange.com](https://chemistry.stackexchange.com)]
- 4. [walshmedicalmedia.com](https://walshmedicalmedia.com) [[walshmedicalmedia.com](https://walshmedicalmedia.com)]
- 5. [pdf.benchchem.com](https://pdf.benchchem.com) [[pdf.benchchem.com](https://pdf.benchchem.com)]
- To cite this document: BenchChem. [controlling phase purity in Cd(II)-H3IDC coordination polymers]. BenchChem, [2026]. [Online PDF]. Available at: [<https://www.benchchem.com/product/b3354744/docs#controlling-phase-purity-in-cd-ii-h3idc-coordination-polymers>]

---

### Disclaimer & Data Validity:

The information provided in this document is for Research Use Only (RUO) and is strictly not intended for diagnostic or therapeutic procedures. While BenchChem strives to provide accurate protocols, we make no warranties, express or implied, regarding the fitness of this product for every specific experimental setup.

**Technical Support:** The protocols provided are for reference purposes. Unsure if this reagent suits your experiment?

**Need Industrial/Bulk Grade?** [Request Custom Synthesis Quote](#)

## BenchChem

Our mission is to be the trusted global source of essential and advanced chemicals, empowering scientists and researchers to drive progress in science and industry.

### Contact

Address: 3281 E Guasti Rd  
Ontario, CA 91761, United States  
Phone: (601) 213-4426  
Email: [info@benchchem.com](mailto:info@benchchem.com)

[Contact our Ph.D. Support Team for a compatibility check](#)