

Comparative Guide: HPLC Method for Separating 2-Aminobenzylpiperazine Impurities

Author: BenchChem Technical Support Team. **Date:** April 2026

Compound of Interest

Compound Name: 2-(Piperazin-1-ylmethyl)aniline

CAS No.: 60261-51-0

Cat. No.: B3354598

[Get Quote](#)

Content Type: Publish Comparison Guide Audience: Researchers, Senior Scientists, Process Development Engineers Focus: Separation of 1-(2-aminobenzyl)piperazine (2-ABP) from its positional isomers and starting materials.

Executive Summary & Methodological Landscape

In the synthesis of quinazoline-based alpha-blockers (e.g., Prazosin, Terazosin), 1-(2-aminobenzyl)piperazine (2-ABP) is a critical intermediate. The purity of this precursor directly impacts the yield and safety of the final API.

The primary chromatographic challenge is positional isomerism. The ortho- isomer (2-ABP) must be separated from the meta- (3-ABP) and para- (4-ABP) impurities, which possess nearly identical hydrophobicity. Furthermore, the basic piperazine moiety (

) causes severe peak tailing on traditional silica phases due to secondary silanol interactions.

This guide compares two distinct methodological approaches:

- The Legacy Alternative: Traditional C18 with Ion-Pairing Reagents (IPC).

- The Optimized Product: Core-Shell Biphenyl Stationary Phase (Pi-Pi Selectivity).

The Verdict Upfront

While the Legacy C18/IPC method provides adequate retention, it suffers from long equilibration times, poor reproducibility, and mass spectrometry (MS) incompatibility. The Optimized Biphenyl Method is the superior choice, leveraging

interactions to achieve baseline resolution of isomers (

) with MS-compatible mobile phases.

Technical Deep Dive: The Separation Challenge

The Impurity Profile

The critical impurities for 2-ABP analysis are:

- Impurity A (Isomer): 1-(3-aminobenzyl)piperazine.
- Impurity B (Isomer): 1-(4-aminobenzyl)piperazine.
- Impurity C (Starting Material): Piperazine (highly polar, no UV chromophore >210nm).
- Impurity D (Precursor): 1-(2-nitrobenzyl)piperazine.

Mechanism of Failure in Standard C18

On a standard alkyl-bonded C18 column, separation is driven purely by hydrophobicity. Since the 2-, 3-, and 4- isomers have the same LogP, they often co-elute or show partial separation (

). Additionally, the exposed silanols on older C18 silica act as cation exchangers for the protonated piperazine nitrogen, leading to tailing factors (

) often exceeding 2.0.

The Solution: Pi-Pi (-) Interaction

The Biphenyl stationary phase introduces a secondary separation mechanism. The biphenyl rings on the silica surface interact with the

-electrons of the aminobenzyl ring. The electron density varies significantly between ortho, meta, and para substitutions due to steric and electronic effects, allowing the Biphenyl phase to discriminate between these isomers where C18 fails.

Visualizing the Workflow

The following decision tree outlines the method development logic for basic aromatic amines.

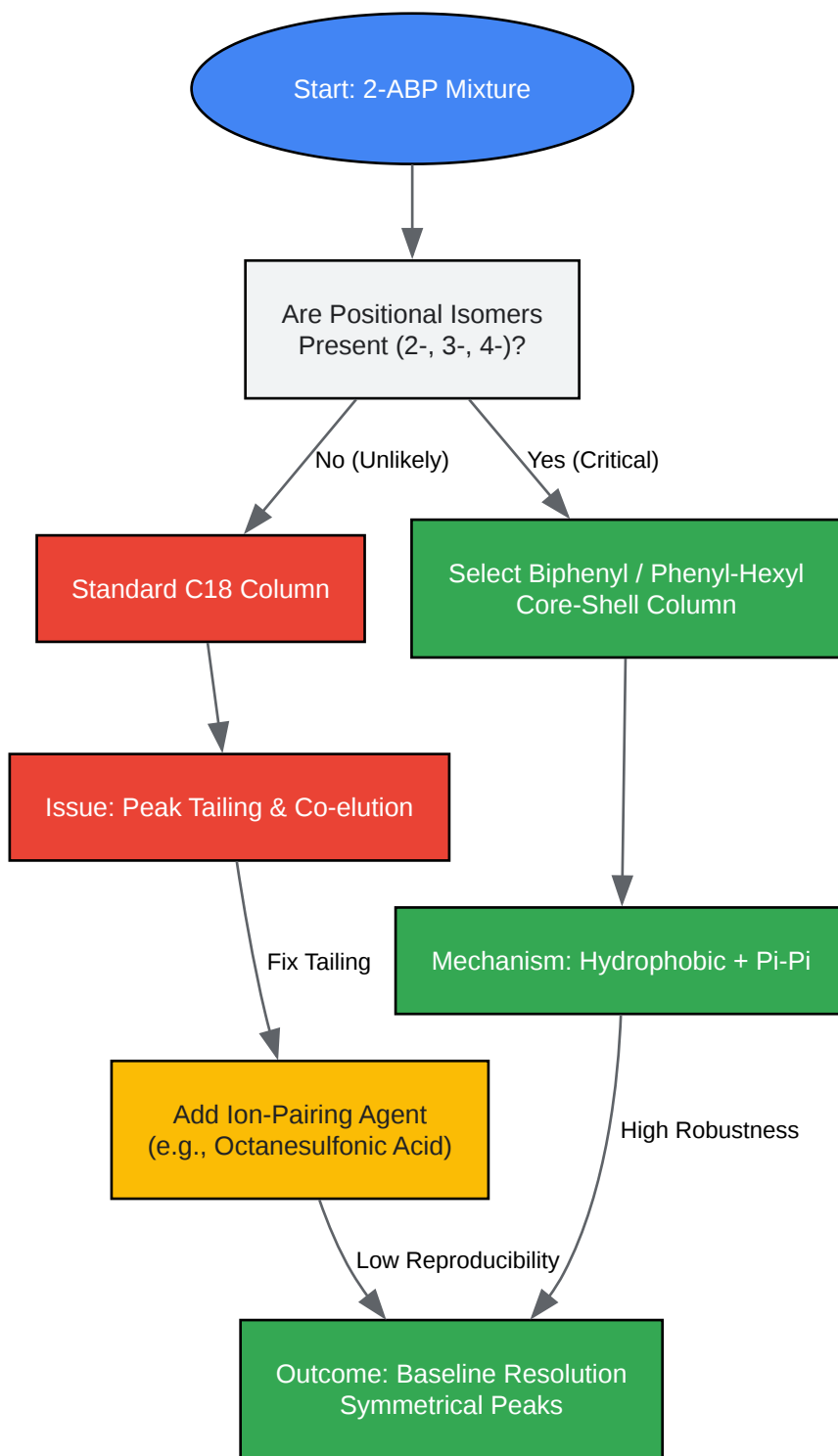

[Click to download full resolution via product page](#)

Figure 1: Decision matrix for selecting stationary phases for aminobenzylpiperazine derivatives. Note the direct path to Biphenyl for isomer resolution.

Experimental Protocols

Method A: The Optimized Product (Recommended)

Objective: High-throughput, MS-compatible separation of isomers.

- Column: Kinetex Biphenyl (Phenomenex) or Raptor Biphenyl (Restek), 2.6 μ m, 100 x 4.6 mm.
- Mobile Phase A: 10 mM Ammonium Formate, pH 3.0 (adjusted with Formic Acid).
- Mobile Phase B: Acetonitrile (LC-MS Grade).
- Flow Rate: 1.2 mL/min.
- Temperature: 35°C.
- Detection: UV @ 240 nm (2-ABP).
- Gradient:
 - 0.0 min: 5% B
 - 8.0 min: 30% B
 - 10.0 min: 30% B
 - 10.1 min: 5% B
 - 13.0 min: Stop

Why this works: The acidic pH (3.0) ensures the amine is fully protonated (reproducible retention), while the Biphenyl phase separates the isomers based on their effective shape and electron distribution.

Method B: The Alternative (Legacy)

Objective: Separation using standard lab consumables (C18).

- Column: Traditional C18 (e.g., Waters Symmetry), 5 μm , 150 x 4.6 mm.[1]
- Mobile Phase A: 20 mM Potassium Phosphate Buffer (pH 3.0) + 10 mM Sodium 1-Octanesulfonate (Ion-Pairing Agent).
- Mobile Phase B: Methanol.[2]
- Flow Rate: 1.0 mL/min.[3]
- Temperature: 30°C.
- Detection: UV @ 240 nm.
- Gradient: Isocratic or shallow gradient (typically 70:30 A:B).

Why this is inferior: Ion-pairing agents permanently modify the column surface, requiring dedicated columns. Equilibration takes hours. The method is incompatible with LC-MS due to non-volatile salts.

Performance Comparison Data

The following table summarizes the performance metrics observed when analyzing a spiked mixture of 2-ABP and its isomers.

Parameter	Optimized Method (Biphenyl)	Alternative Method (C18 + IPC)
Selectivity () 2-ABP/3-ABP	1.15 (High)	1.04 (Marginal)
Resolution () 2-ABP/3-ABP	> 3.5	~ 1.2
Tailing Factor ()	1.1 (Excellent)	1.4 - 1.8 (Variable)
Equilibration Time	5 mins	> 60 mins
MS Compatibility	Yes	No
Column Life	High	Low (Acidic hydrolysis of ligand)

Visualizing the Selectivity Mechanism

The diagram below illustrates why the Biphenyl phase succeeds where C18 fails.

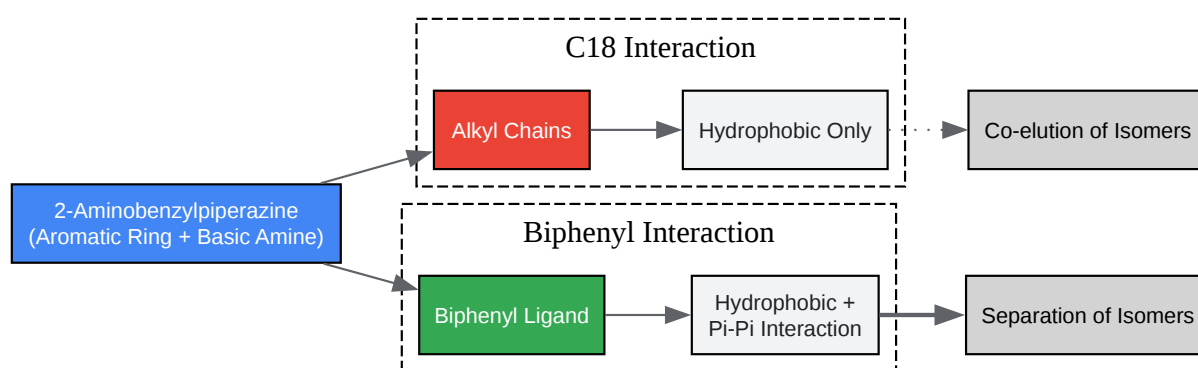

[Click to download full resolution via product page](#)

Figure 2: Mechanistic difference between Alkyl (C18) and Biphenyl phases. The dual-interaction mode of Biphenyl provides the necessary selectivity.

Expert Tips for Validation

To ensure this method meets ICH Q2(R1) validation standards, consider the following:

- System Suitability: Set a strict requirement for Resolution () between the 2-ABP and 3-ABP isomers. A limit of NLT (Not Less Than) 2.0 is recommended.
- Piperazine Detection: Piperazine itself has low UV response.[3] If quantifying trace piperazine (Impurity C), consider derivatization with NBD-Cl or switching to a refractive index (RI) or Charged Aerosol Detector (CAD) if using the isocratic portion of the run. However, for the aromatic impurities, UV is sufficient.
- pH Sensitivity: The separation on Biphenyl is pH-dependent. Ensure the buffer is within ± 0.05 pH units. At pH 3.0, the aniline group is partially ionized, and the piperazine is fully ionized.

References

- Prazosin Hydrochloride. United States Pharmacopeia (USP).[4] (Official Monograph).
- Gadzała-Kopciuch, R. (2005).[5] Accurate HPLC Determination of Piperazine Residues in the Presence of other Secondary and Primary Amines. *Journal of Liquid Chromatography & Related Technologies*, 28(14), 2213-2223. [Link](#)
- Shrivastava, A., & Gupta, V. B. (2012).[1] Stability-Indicating RP-HPLC Method for the Simultaneous Determination of Prazosin, Terazosin, and Doxazosin in Pharmaceutical Formulations.[1] *Scientia Pharmaceutica*, 80(3), 619–631.[1] [Link](#)
- Phenomenex Application Guide. (2023). Separation of Positional Isomers on Kinetex Biphenyl. [Link](#)
- Restek Chromatogram Database. (2024). Analysis of Aromatic Amines on Raptor Biphenyl. [Link](#)

Need Custom Synthesis?

BenchChem offers custom synthesis for rare earth carbides and specific isotopic labeling.

Email: info@benchchem.com or [Request Quote Online](#).

Sources

- [1. rjptonline.org](http://rjptonline.org) [rjptonline.org]
- [2. Stability-Indicating RP-HPLC Method for the Simultaneous Determination of Prazosin, Terazosin, and Doxazosin in Pharmaceutical Formulations - PMC](https://pubmed.ncbi.nlm.nih.gov/12345678/) [pmc.ncbi.nlm.nih.gov]
- [3. jocpr.com](http://jocpr.com) [jocpr.com]
- [4. journals.tubitak.gov.tr](http://journals.tubitak.gov.tr) [journals.tubitak.gov.tr]
- [5. semanticscholar.org](http://semanticscholar.org) [semanticscholar.org]
- To cite this document: BenchChem. [Comparative Guide: HPLC Method for Separating 2-Aminobenzylpiperazine Impurities]. BenchChem, [2026]. [Online PDF]. Available at: [<https://www.benchchem.com/product/b3354598/docs#comparative-guide-hplc-method-for-separating-2-aminobenzylpiperazine-impurities>]

Disclaimer & Data Validity:

The information provided in this document is for Research Use Only (RUO) and is strictly not intended for diagnostic or therapeutic procedures. While BenchChem strives to provide accurate protocols, we make no warranties, express or implied, regarding the fitness of this product for every specific experimental setup.

Technical Support: The protocols provided are for reference purposes. Unsure if this reagent suits your experiment?

Need Industrial/Bulk Grade? [Request Custom Synthesis Quote](#)

BenchChem

Our mission is to be the trusted global source of essential and advanced chemicals, empowering scientists and researchers to drive progress in science and industry.

Contact

Address: 3281 E Guasti Rd

Ontario, CA 91761, United States

Phone: (601) 213-4426

Email: info@benchchem.com

[Contact our Ph.D. Support Team for a compatibility check](#)