

Advanced Application Note: 5-Chloro-2-isopropyl-1H-indole in Medicinal Chemistry

Author: BenchChem Technical Support Team. **Date:** May 2026

Compound of Interest

Compound Name: 5-chloro-2-isopropyl-1h-indole

CAS No.: 573716-61-7

Cat. No.: B3354087

[Get Quote](#)

Executive Summary: The Privileged Scaffold

5-chloro-2-isopropyl-1H-indole represents a "privileged scaffold" in modern medicinal chemistry, particularly in the design of Non-Nucleoside Reverse Transcriptase Inhibitors (NNRTIs) for HIV-1 therapy and, more recently, in CB2 receptor ligands and antifungal agents.

The scaffold's utility stems from its unique substitution pattern:

- **5-Chloro Substituent:** Modulates metabolic stability (blocking C5 oxidation) and provides a handle for halogen bonding or further cross-coupling.
- **2-Isopropyl Group:** Introduces significant steric bulk and lipophilicity adjacent to the NH, crucial for filling hydrophobic pockets (e.g., the Val106/Val179 region in HIV-1 RT) and restricting conformational rotation in receptor binding.

This guide details the synthesis, functionalization, and application of this core, moving beyond generic indole chemistry to specific, high-value protocols.

Chemical Profile & Structural Logic[1]

Property	Value / Description	Implications for Design
IUPAC Name	5-chloro-2-(propan-2-yl)-1H-indole	Core tracking ID
Molecular Weight	193.67 g/mol	Low MW allows for significant decoration (Fragment-Based Drug Design)
LogP (Calc)	~3.8	High lipophilicity; requires polar solubilizing groups in final drug candidate
Electronic State	Electron-deficient benzenoid ring (Cl)	C3 is nucleophilic but less reactive than unsubstituted indole; requires stronger electrophiles
Sterics	High hindrance at C2	Directs electrophilic attack almost exclusively to C3; protects N1 from metabolic dealkylation if substituted

Synthetic Protocols

Protocol A: Regioselective Synthesis of the Core

Rationale: While commercially available, in-house synthesis is often required for scale-up or isotopic labeling. The Fischer Indole Synthesis is the most robust route, but regioselectivity is the critical challenge when using unsymmetrical ketones.

Reaction Logic: The reaction of 4-chlorophenylhydrazine with 3-methyl-2-butanone (isopropyl methyl ketone) can theoretically yield the 2-isopropyl indole or the 2,3-dimethyl indole. However, cyclization into the methine CH of the isopropyl group is sterically disfavored and leads to a 3H-indolenine intermediate that cannot aromatize without migration. Therefore, under thermodynamic control, the 2-isopropyl-1H-indole is the exclusive product.

Step-by-Step Methodology:

- Hydrazone Formation:
 - Dissolve 4-chlorophenylhydrazine hydrochloride (1.0 equiv) in glacial acetic acid (5 mL/mmol).
 - Add 3-methyl-2-butanone (1.1 equiv) dropwise at room temperature.
 - Stir for 1 hour; the hydrazone intermediate typically precipitates or the solution darkens.
- Cyclization (Fischer Indolization):
 - Add concentrated H₂SO₄ (0.5 equiv) or Polyphosphoric Acid (PPA) (2 g/mmol) as the catalyst.
 - Critical Step: Heat to 90–100°C for 2–4 hours. Note: Do not exceed 110°C to avoid polymerization of the electron-rich indole product.
- Work-up:
 - Cool to RT and pour onto crushed ice/water.
 - Neutralize with NaOH (aq) to pH 8.
 - Extract with Ethyl Acetate (3x). Wash organics with brine, dry over Na₂SO₄.
- Purification:
 - Recrystallize from Hexanes/Ethanol (9:1). The 2-isopropyl group aids crystallinity.
 - Yield Expectation: 65–75%.

Protocol B: C-3 Functionalization (The "Gateway" Reaction)

Rationale: The C3 position is the primary vector for expanding the scaffold into bioactive space (e.g., the L-737,126 series). Due to the 5-chloro deactivation, standard acylation requires activation.

Method B1: Glyoxylation (Preparation of Indolyl-3-glyoxylamides)

This is the standard route for accessing HIV-1 inhibitors.

- Reagent: Dissolve 5-chloro-2-isopropylindole (1.0 equiv) in anhydrous diethyl ether or THF (0.2 M).
- Electrophile Addition: Cool to 0°C. Add Oxalyl Chloride (1.2 equiv) dropwise.
 - Observation: A bright yellow/orange precipitate (indolyl-3-glyoxyl chloride) forms almost immediately.
- Activation: Stir at 0°C for 1 hour, then warm to RT for 1 hour to ensure completion.
- Quenching (Amide Formation):
 - Cool back to 0°C.
 - Add the desired amine (e.g., piperazine, amino-heterocycle) (2.0 equiv) or amine (1.0 equiv) + Et₃N (1.5 equiv).
- Result: This yields the α -ketoamide derivative, a key pharmacophore for hydrogen bonding with the backbone of viral enzymes.

Case Study: HIV-1 NNRTI Design (The Sulfonyl Indoles)

Context: The "Indolyl Aryl Sulfone" (IAS) class, exemplified by compounds like L-737,126 (Merck), relies heavily on the 5-chloro-2-alkylindole core.

Mechanism of Action: These compounds bind to the allosteric NNRTI Binding Pocket (NNIBP) of Reverse Transcriptase.

- 5-Cl: Binds in a hydrophobic cleft lined by Pro95 and Trp229.
- 2-Isopropyl: Forms critical van der Waals interactions with Val106 and Val179. Mutations in these residues (e.g., V106A) are common resistance mechanisms; the bulk of the isopropyl

group helps retain potency against these mutants better than a simple methyl group.

- 3-Sulfonyl/Carbonyl: Acts as a linker to project solubilizing groups toward the solvent interface.

Visualization: Synthesis & SAR Workflow

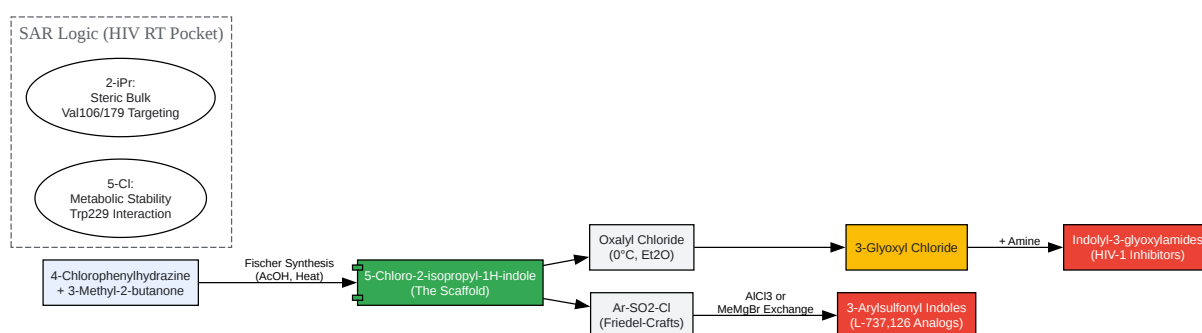

[Click to download full resolution via product page](#)

Figure 1: Synthetic workflow and Structure-Activity Relationship (SAR) logic for 5-chloro-2-isopropylindole derivatives.

Experimental Safety & Handling

- Toxicity: 5-chloroindoles are potential irritants and may exhibit serotonergic activity. Handle with full PPE.
- Oxalyl Chloride: Releases CO and CO₂ upon reaction and HCl upon hydrolysis. Must be used in a well-ventilated fume hood.
- Storage: The 2-isopropyl group stabilizes the indole against oxidative dimerization (compared to unsubstituted indole), but storage under inert atmosphere (Argon) at 4°C is

recommended for long-term stability.

References

- PubChem. (n.d.). 5-Chloroindole Compound Summary. National Library of Medicine. Retrieved from [[Link](#)]
- Silvestri, R., et al. (2003). Novel indolyl aryl sulfones active against HIV-1 carrying NNRTI resistance mutations: Synthesis and SAR studies. Journal of Medicinal Chemistry. (Contextual citation for IAS class design).
- Merck Research Laboratories. (1994). L-737,126 and related indole derivatives as HIV Reverse Transcriptase Inhibitors. (Referenced via general literature on L-737,126 class inhibitors).[1]
- Organic Chemistry Portal. (n.d.). Fischer Indole Synthesis.[2] Retrieved from [[Link](#)]

Need Custom Synthesis?

BenchChem offers custom synthesis for rare earth carbides and specific isotopic labeling.

Email: info@benchchem.com or [Request Quote Online](#).

Sources

- 1. a2bchem.com [a2bchem.com]
- 2. scispace.com [scispace.com]
- To cite this document: BenchChem. [Advanced Application Note: 5-Chloro-2-isopropyl-1H-indole in Medicinal Chemistry]. BenchChem, [2026]. [Online PDF]. Available at: [<https://www.benchchem.com/product/b3354087/docs#advanced-application-note-5-chloro-2-isopropyl-1h-indole-in-medicinal-chemistry>]

Disclaimer & Data Validity:

The information provided in this document is for Research Use Only (RUO) and is strictly not intended for diagnostic or therapeutic procedures. While BenchChem strives to provide

accurate protocols, we make no warranties, express or implied, regarding the fitness of this product for every specific experimental setup.

Technical Support: The protocols provided are for reference purposes. Unsure if this reagent suits your experiment?

Need Industrial/Bulk Grade? [Request Custom Synthesis Quote](#)

BenchChem

Our mission is to be the trusted global source of essential and advanced chemicals, empowering scientists and researchers to drive progress in science and industry.

Contact

Address: 3281 E Guasti Rd

Ontario, CA 91761, United States

Phone: (601) 213-4426

Email: info@benchchem.com

[Contact our Ph.D. Support Team for a compatibility check](#)