

comparative stability of HCFC-244ca versus HCFC-244bb isomers

Author: BenchChem Technical Support Team. **Date:** May 2026

Compound of Interest

Compound Name: 1-Chloro-1,1,2,2-tetrafluoropropane

CAS No.: 421-75-0

Cat. No.: B3352110

[Get Quote](#)

Topic: Comparative Stability of HCFC-244ca versus HCFC-244bb Isomers Content Type: Technical Comparison Guide Audience: Researchers, Process Chemists, and Drug Development Professionals

Executive Summary: The Stability Paradox

In the synthesis of next-generation fluoro-olefins (HFOs), the isomers of HCFC-244 () present a critical dichotomy.

- HCFC-244bb (2-chloro-1,1,1,2-tetrafluoropropane) is a reactive intermediate, designed to be thermodynamically unstable under catalytic conditions to facilitate the production of HFO-1234yf.
- HCFC-244ca (1-chloro-2,2,3,3-tetrafluoropropane) is a highly stable impurity. Its structural arrangement renders it chemically inert to the standard dehydrochlorination pathways used for 244bb.

This guide provides a mechanistic analysis of why 244bb reacts while 244ca persists, supported by structural data and experimental protocols for validating these properties in the lab.

Structural Analysis & Mechanistic Causality

The divergence in stability is not merely a difference in bond energy but a result of structural availability for beta-elimination.

Chemical Structures

Feature	HCFC-244bb	HCFC-244ca
IUPAC Name	2-chloro-1,1,1,2-tetrafluoropropane	1-chloro-2,2,3,3-tetrafluoropropane
Formula		
C-Cl Bond Position	Secondary () Carbon	Primary () Carbon
-Hydrogens	3 (on the methyl group)	0 (on the adjacent group)
Primary Decay Mode	Dehydrochlorination (-HCl)	Dehydrofluorination (-HF) (High Energy)

The Beta-Elimination Blockade

- HCFC-244bb: The chlorine atom is on C2.^[1] The adjacent C3 is a methyl group () containing three available hydrogen atoms. This structural setup is perfect for E2 elimination, where a base (or catalyst surface) abstracts a proton from C3 while Cl leaves C2, forming the double bond of HFO-1234yf ().
- HCFC-244ca: The chlorine atom is on C1. The adjacent C2 is a perfluorinated methylene group (

). There are no protons on the beta-carbon to abstract. Consequently, dehydrochlorination is mechanistically blocked. The molecule must undergo a much higher energy pathway (such as C-C bond scission or dehydrofluorination involving C1 hydrogens) to degrade.

Visualizing the Reaction Pathways

The following diagram illustrates the divergent fates of these isomers under catalytic conditions.

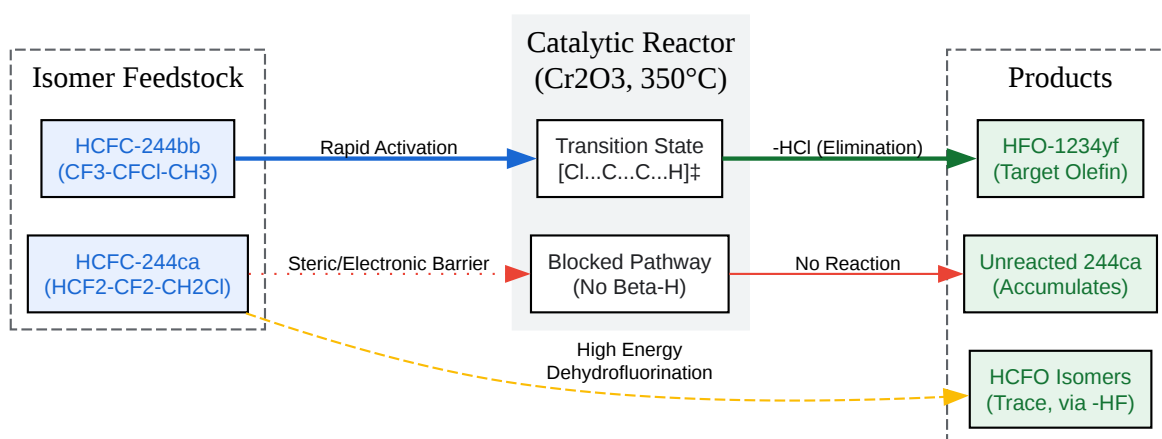

[Click to download full resolution via product page](#)

Figure 1: Mechanistic divergence of HCFC-244 isomers. 244bb undergoes facile elimination to form HFO-1234yf, while 244ca lacks the structural requirements for HCl loss, resulting in accumulation.

Comparative Performance Data

The following data summarizes the stability profile based on catalytic dehydrochlorination experiments over fluorinated chromia (

) catalyst.

Parameter	HCFC-244bb	HCFC-244ca	Implication
Conversion @ 350°C	> 50%	< 2%	244bb is the active precursor; 244ca is an inert impurity.
Selectivity to 1234yf	> 95%	~0%	244ca does not yield the target product.
Activation Energy ()	~15-20 kcal/mol	> 45 kcal/mol (est)	244ca requires significantly higher energy to degrade.
Primary Byproduct	HCFC-1233xf (via - HF)	HCFO-1233yd (via - HF)	Different degradation pathways complicate purification.
Boiling Point	~14°C	~25°C	Separation by distillation is possible but energy-intensive.

“

Note: Data derived from standard industrial dehydrochlorination conditions (Gas Hourly Space Velocity = 1000

, 1 atm).

Experimental Protocol: Catalytic Stability Assay

To verify the stability difference in your own laboratory, use this self-validating protocol. This assay compares the conversion rates of both isomers under identical stress conditions.

Objective

Quantify the conversion of HCFC-244 isomers to olefinic products over a Lewis Acid catalyst.

Materials

- Reactor: Inconel 600 tube (1/2" OD, 12" length).
- Catalyst: High-surface area Chromium(III) Oxide () pellets.
- Feedstock: Pure HCFC-244bb and HCFC-244ca (purity >99%).
- Analysis: GC-FID/MS with a cryo-cooled column (e.g., DB-1 or Porapak Q).

Workflow

- Catalyst Activation (Critical Step):
 - Load 20 mL of catalyst into the reactor.
 - Heat to 300°C under flow (200 sccm) for 2 hours to remove moisture.
 - Validation Check: Ensure reactor effluent shows no water peak on GC.
 - Treat with anhydrous HF (20 sccm) diluted in for 4 hours to fluorinate the surface (activates Lewis acid sites).
- Reaction Run (Isothermal Mode):
 - Set reactor temperature to 350°C.
 - Feed HCFC-244bb at 10 g/h (co-feed optional).
 - Collect effluent gases for 1 hour in a Tedlar bag or online sampling loop.
 - Purge system with

for 1 hour.

- Repeat the process with HCFC-244ca.[1]
- Data Analysis:
 - Calculate Conversion ():
 - Expected Result: 244bb conversion should exceed 40-50%. 244ca conversion should be negligible (<5%).
- Troubleshooting:
 - If 244ca conversion is high: Check for thermal pyrolysis (reactor hot spots >500°C) or catalyst contamination with strong bases.

References

- Honeywell International Inc. (2012). Synthesis of 1234yf by selective dehydrochlorination of 244bb. Patent WO2012006295A1. [Link](#)
- National Oceanic and Atmospheric Administration (NOAA). HCFC-244ca Molecular Structure and Atmospheric Lifetime. [Link](#)
- PubChem. Compound Summary: 2-chloro-1,1,1,2-tetrafluoropropane (HCFC-244bb).[2] [Link](#)
- Journal of Fluorine Chemistry. Catalytic dehydrohalogenation of hydrochlorofluorocarbons. (General reference for mechanism). [Link](#)
- U.S. Environmental Protection Agency (EPA). Significant New Alternatives Policy (SNAP) Program: HFO-1234yf. [Link](#)

Need Custom Synthesis?

BenchChem offers custom synthesis for rare earth carbides and specific isotopic labeling.

Email: info@benchchem.com or [Request Quote Online](#).

Sources

- 1. WO2019203318A1 - [Method for producing fluorine-containing unsaturated hydrocarbon](#) - Google Patents [patents.google.com]
- 2. WO2019208546A1 - [Method for producing fluorine-containing unsaturated hydrocarbon](#) - Google Patents [patents.google.com]
- To cite this document: BenchChem. [comparative stability of HCFC-244ca versus HCFC-244bb isomers]. BenchChem, [2026]. [Online PDF]. Available at: [\[https://www.benchchem.com/product/b3352110/docs#comparative-stability-of-hcfc-244ca-versus-hcfc-244bb-isomers\]](https://www.benchchem.com/product/b3352110/docs#comparative-stability-of-hcfc-244ca-versus-hcfc-244bb-isomers)

Disclaimer & Data Validity:

The information provided in this document is for Research Use Only (RUO) and is strictly not intended for diagnostic or therapeutic procedures. While BenchChem strives to provide accurate protocols, we make no warranties, express or implied, regarding the fitness of this product for every specific experimental setup.

Technical Support: The protocols provided are for reference purposes. Unsure if this reagent suits your experiment?

Need Industrial/Bulk Grade? [Request Custom Synthesis Quote](#)

BenchChem

Our mission is to be the trusted global source of essential and advanced chemicals, empowering scientists and researchers to drive progress in science and industry.

Contact

Address: 3281 E Guasti Rd

Ontario, CA 91761, United States

Phone: (601) 213-4426

Email: info@benchchem.com

Contact our Ph.D. Support Team for a compatibility check