

Application Note: Mass Spectrometry Profiling and Quantification of Piperazine-Containing Molecules

Author: BenchChem Technical Support Team. **Date:** April 2026

Compound of Interest

Compound Name:	4-Hydroxy-1-(4-methylpiperazin-1-yl)butan-1-one
CAS No.:	393785-45-0
Cat. No.:	B3351728

[Get Quote](#)

Abstract

Piperazine moieties represent a privileged scaffold in medicinal chemistry, appearing in a vast array of antidepressants, antihistamines, antipsychotics, and designer drugs (e.g., BZP). Their analysis via Liquid Chromatography-Tandem Mass Spectrometry (LC-MS/MS) presents unique challenges and opportunities due to the ring's high basicity and specific fragmentation behaviors. This guide provides a comprehensive technical framework for the detection, metabolic profiling, and quantification of piperazine-containing molecules, moving beyond standard operating procedures to explore the mechanistic "why" behind successful method development.

Introduction: The Piperazine Pharmacophore

The piperazine ring is a six-membered heterocycle containing two nitrogen atoms at opposite positions (1,4-placement).^[1] In the context of mass spectrometry, this structure dictates the analytical strategy:

- Protonation Kinetics: The secondary amines render the molecule highly basic ($pK_a \sim 9.8$), making Electrospray Ionization (ESI) in Positive Mode the gold standard. The molecule readily accepts protons, often forming

or

species depending on the mobile phase pH.
- Fragmentation Logic: Unlike aliphatic chains that fragment randomly, piperazine rings undergo predictable cleavage events—specifically Retro-Diels-Alder (RDA) reactions and -cleavages—which serve as diagnostic fingerprints for structural elucidation.

Mechanistic Insights: Fragmentation Pathways

Understanding how the piperazine ring breaks apart is crucial for selecting Robust Multiple Reaction Monitoring (MRM) transitions.

The Physics of Cleavage

Two primary mechanisms dominate the Collision-Induced Dissociation (CID) of these molecules:

- -Cleavage (Iminium Ion Formation): The ionization of the nitrogen triggers a radical site instability, leading to the cleavage of the C-C bond adjacent to the nitrogen.^[2] This often results in the loss of side chains.
- Retro-Diels-Alder (RDA) Reaction: Particularly common in unsaturated or fused-ring piperazine derivatives, the ring unzips to form an imine and an alkene. This is a hallmark of metabolic identification.

Visualization of Fragmentation Logic

The following diagram illustrates the decision tree for selecting quantifier and qualifier ions based on these mechanisms.

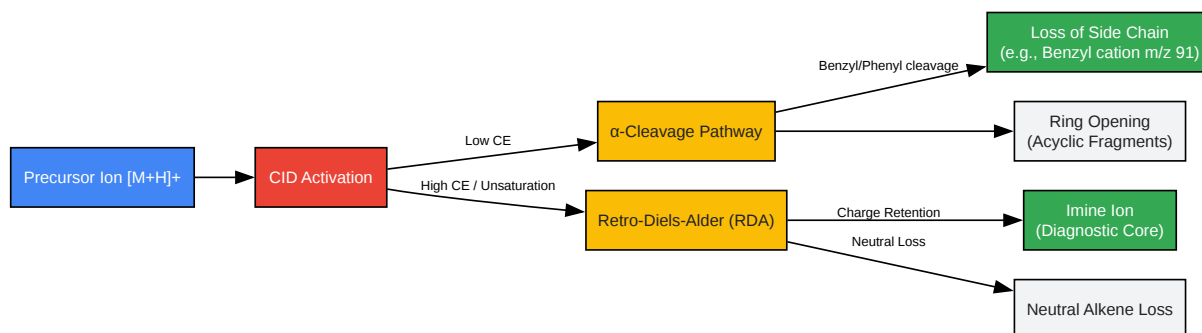

[Click to download full resolution via product page](#)

Caption: Figure 1. Mechanistic divergence in piperazine fragmentation.

-cleavage typically yields side-chain specific ions (useful for class identification), while RDA provides ring-specific structural data.

Method Development Guide

Chromatographic Conditions

Because piperazines are polar bases, they suffer from peak tailing on standard C18 columns due to interaction with residual silanols.

- Column Selection: Use end-capped C18 or Polar-Embedded phases (e.g., Phenomenex Synergi Hydro-RP or Waters XSelect CSH). These shield silanols and improve peak symmetry.
- Mobile Phase Chemistry:
 - Aqueous (A): [3][4] 10 mM Ammonium Formate + 0.1% Formic Acid. (Buffer is critical to maintain constant ionization state).
 - Organic (B): Acetonitrile (preferred over Methanol for sharper peaks).
 - Gradient: Start at 5-10% B to retain the polar piperazine core, ramping to 95% B.

Mass Spectrometry Parameters (Source: ESI+)

- Capillary Voltage: 3.0 - 3.5 kV (Avoid higher voltages which may cause in-source fragmentation).
- Desolvation Temp: 400°C - 500°C (High heat required to desolvate the polar nitrogenous species).
- Cone Voltage: Optimize per compound. Piperazines are robust; typical range 20-40V.

Reference Data: Common Diagnostic Ions

Compound Class	Precursor Type	Characteristic Fragment (m/z)	Origin
Benzylpiperazines (BZP)		91.0	Tropylium ion (Benzyl cleavage)
Phenylpiperazines		119.0, 70.0	Phenyl-N cleavage, Ring fragment
mCPP		154.0	Chlorophenyl fragment
General Piperazine		56.0, 44.0	Ring cleavage (C ₂ H ₄ N ⁺)

Experimental Protocols

Protocol A: Sample Preparation (Biological Matrix)

Objective: Isolate piperazine drugs from plasma while removing proteins and phospholipids that cause ion suppression. Method: Liquid-Liquid Extraction (LLE) is superior to protein precipitation for piperazines due to the ability to manipulate pH.

Reagents:

- Ammonium Hydroxide (concentrated)
- Extraction Solvent: Ethyl Acetate:Hexane (90:10 v/v)

- Internal Standard (IS): Deuterated analog (e.g., BZP-d7)[5]

Step-by-Step Workflow:

- Aliquot: Transfer 200 μ L of plasma into a glass tube.
- Spike: Add 20 μ L of Internal Standard working solution.
- Alkalinize: Add 50 μ L of 5%
 - Scientific Rationale: This adjusts pH > 10, ensuring the piperazine nitrogens are deprotonated (neutral). Only the neutral form partitions into the organic layer.
- Extract: Add 2 mL of Extraction Solvent. Vortex vigorously for 2 minutes.
- Separate: Centrifuge at 3000 x g for 5 minutes.
- Transfer: Transfer the upper organic layer to a clean tube.
- Dry: Evaporate to dryness under
at 40°C.
- Reconstitute: Dissolve residue in 100 μ L Mobile Phase A.
 - Note: The acidic mobile phase immediately reprotonates the piperazine, preparing it for ESI+ detection.

Protocol B: LC-MS/MS Quantification Workflow

This workflow uses a standard Triple Quadrupole (QqQ) setup.

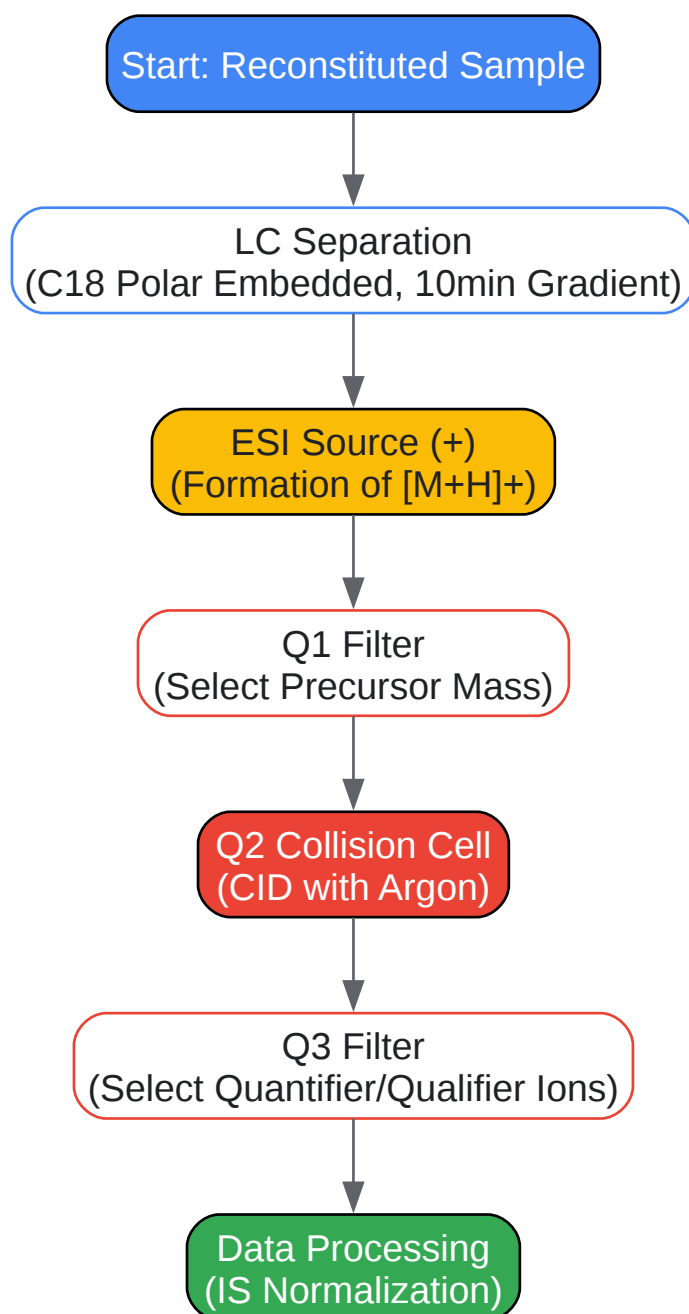

[Click to download full resolution via product page](#)

Caption: Figure 2. Linear quantification workflow. The transition from Q1 to Q3 relies on the specific collision energies optimized for the piperazine ring stability.

Troubleshooting & Optimization

Matrix Effects (Ion Suppression)

Piperazines elute early in Reversed-Phase chromatography, often co-eluting with phospholipids.

- **Diagnosis:** Post-column infusion of the analyte while injecting a blank matrix extract. Look for dips in the baseline.
- **Solution:** If LLE is insufficient, switch to Mixed-Mode Cation Exchange (MCX) SPE. The piperazine binds to the sulfonic acid groups on the sorbent, allowing rigorous washing of interferences before elution with ammoniated methanol.

Carryover

Due to the "sticky" nature of basic amines on stainless steel:

- **Wash Solvent:** Use a needle wash of Acetonitrile:Isopropanol:Water:Formic Acid (40:40:20:0.5). The acid is vital to keep the amine soluble and positively charged, preventing adsorption to the injector needle.

References

- Zhu, N., et al. (2021).[3] "Mass Fragmentation Characteristics of Piperazine Analogues." *Journal of Chinese Mass Spectrometry Society*. [3](#)
- Wohlfarth, A., et al. (2010).[6] "LC-MS/MS screening method for designer amphetamines, tryptamines, and piperazines in serum." *Analytical and Bioanalytical Chemistry*. [Link](#)
- BenchChem Technical Support. (2025). "High-Throughput Quantification of Piperazin-2-one in Biological Matrices using a Validated LC-MS/MS Method." *Application Note*. [7](#)
- Li Research Group. (2021). "Retro Diels–Alder Fragmentation of Fulvene–Maleimide Bioconjugates for Mass Spectrometric Detection." *Analytical Chemistry*. [Link](#)
- Scientific Working Group for the Analysis of Seized Drugs (SWGDRUG). "Mass Spectral Library and Literature." [Link](#)

Need Custom Synthesis?

BenchChem offers custom synthesis for rare earth carbides and specific isotopic labeling.

Email: info@benchchem.com or [Request Quote Online](#).

Sources

- [1. pdf.benchchem.com \[pdf.benchchem.com\]](https://pdf.benchchem.com)
- [2. pdf.benchchem.com \[pdf.benchchem.com\]](https://pdf.benchchem.com)
- [3. Mass Fragmentation Characteristics of Piperazine Analogues \[zpxb.xml-journal.net\]](https://zpxb.xml-journal.net)
- [4. 25. Retro Diels–Alder Fragmentation of Fulvene–Maleimide Bioconjugates for Mass Spectrometric Detection of Biomolecules — Li Research Group \[peptide-li.com\]](https://peptide-li.com)
- [5. Comparison of LC-MS and LC-DAD Methods of Detecting Abused Piperazine Designer Drugs - PMC \[pmc.ncbi.nlm.nih.gov\]](https://pmc.ncbi.nlm.nih.gov)
- [6. researchgate.net \[researchgate.net\]](https://researchgate.net)
- [7. pdf.benchchem.com \[pdf.benchchem.com\]](https://pdf.benchchem.com)
- To cite this document: BenchChem. [Application Note: Mass Spectrometry Profiling and Quantification of Piperazine-Containing Molecules]. BenchChem, [2026]. [Online PDF]. Available at: [<https://www.benchchem.com/product/b3351728/docs#application-note-mass-spectrometry-profiling-and-quantification-of-piperazine-containing-molecules>]

Disclaimer & Data Validity:

The information provided in this document is for Research Use Only (RUO) and is strictly not intended for diagnostic or therapeutic procedures. While BenchChem strives to provide accurate protocols, we make no warranties, express or implied, regarding the fitness of this product for every specific experimental setup.

Technical Support: The protocols provided are for reference purposes. Unsure if this reagent suits your experiment?

Need Industrial/Bulk Grade? [Request Custom Synthesis Quote](#)

BenchChem

Our mission is to be the trusted global source of essential and advanced chemicals, empowering scientists and researchers to drive progress in science and industry.

Contact

Address: 3281 E Guasti Rd

Ontario, CA 91761, United States

Phone: (601) 213-4426

Email: info@benchchem.com

[Contact our Ph.D. Support Team for a compatibility check](#)