

# Comparative Guide: Mass Spectrometry Fragmentation of N-Ethynylcarbazole

**Author:** BenchChem Technical Support Team. **Date:** April 2026

## Compound of Interest

Compound Name: 9-ethynyl-9H-carbazole

CAS No.: 26157-62-0

Cat. No.: B3350210

[Get Quote](#)

## Executive Summary

This guide provides an in-depth technical analysis of the mass spectrometry (MS) fragmentation patterns of N-ethynylcarbazole (**9-ethynyl-9H-carbazole**). As a functionalized ynamine and a critical monomer in optoelectronic materials and potential pharmaceutical intermediates, its structural characterization requires precise differentiation from its analogs.

We compare N-ethynylcarbazole directly against its structural relatives: Carbazole (parent) and N-ethylcarbazole (alkylated analog). This comparison highlights the unique "triple-bond influence" on fragmentation stability and ionization pathways, providing a self-validating protocol for identification.

## Chemical Identity & Structural Basis[1]

Before interpreting the spectra, it is critical to understand the stability of the N-substituent, as this dictates the primary fragmentation channel.

Compound	Structure Description	Formula	MW (Da)	Key Feature
N-Ethynylcarbazole	Carbazole ring with N-C≡CH	C <sub>14</sub> H <sub>9</sub> N	191.23	-hybridized N-C bond; rigid, conjugated.
N-Ethylcarbazole	Carbazole ring with N-CH <sub>2</sub> -CH <sub>3</sub>	C <sub>14</sub> H <sub>13</sub> N	195.26	-hybridized N-C bond; flexible, labile alkyl chain.
Carbazole	Unsubstituted parent ring	C <sub>12</sub> H <sub>9</sub> N	167.21	Aromatic stability; reference standard.

## Instrumentation & Methodology

To replicate the fragmentation patterns described below, the following experimental parameters are recommended. This protocol ensures high reproducibility and minimizes thermal degradation of the alkyne moiety prior to ionization.

### Protocol: Electron Ionization (EI-MS) Analysis

- **Sample Preparation:** Dissolve 0.1 mg of N-ethynylcarbazole in 1 mL of HPLC-grade Dichloromethane (DCM). Note: Avoid protic solvents like methanol to prevent potential solvolysis of the ynamine.
- **Inlet System:** Direct Insertion Probe (DIP) is preferred over GC to prevent thermal polymerization of the ethynyl group in the liner.
  - If GC is necessary: Use a short, non-polar column (e.g., DB-5MS, 15m) with a high flow rate (1.5 mL/min) to minimize residence time.
- **Ionization Parameters:**
  - **Source Temp:** 230°C (Keep moderate to avoid pyrolysis).

- Electron Energy: 70 eV (Standard library matching).
- Mass Range: m/z 50–300.

## Fragmentation Analysis: N-Ethynylcarbazole

The mass spectrum of N-ethynylcarbazole is dominated by the stability of the aromatic carbazole system. Unlike alkyl-substituted carbazoles, the

-hybridized nitrogen-carbon bond is significantly stronger, altering the fragmentation kinetics.

### Primary Fragmentation Pathways

#### 1. Molecular Ion (

): m/z 191

- Observation: The base peak (100% relative abundance) is typically the molecular ion

.

- Mechanism: The extended

-conjugation between the carbazole ring and the ethynyl group stabilizes the radical cation, making it highly resistant to fragmentation compared to alkyl analogs.

#### 2. Loss of Ethynyl Radical (

): m/z 166

- Transition:
- Mechanism: Homolytic cleavage of the N-C(

) bond releases the ethynyl radical (

).

- Significance: This generates the carbazolyl cation (

). This is a diagnostic transition. While the N-alkynyl bond is strong, the high stability of the resulting aromatic carbazolyl species drives this pathway at high energies.

### 3. Ring Contraction & HCN Elimination (

)

- Transition:
- Mechanism: The carbazolyl cation undergoes ring contraction and expels a neutral Hydrogen Cyanide (HCN, 27 Da) molecule.
- Result: Formation of the fluorenyl-type cation ( ), a classic signature of nitrogen heterocycles.

### 4. Absence of

#### -Cleavage

- Crucial Distinction: Unlike N-ethylcarbazole, N-ethynylcarbazole cannot undergo McLafferty rearrangement or simple

-cleavage (loss of methyl) because it lacks

-hydrogens and the terminal group is rigid.

## Comparative Analysis: The "Fingerprint" Differences

This section provides the data required to distinguish the target from its common impurities or analogs.[1]

### Table 1: Key Diagnostic Ions Comparison

Ion Identity	N-Ethynylcarbazole (Target)	N-Ethylcarbazole (Analog)	Carbazole (Parent)
Molecular Ion ( )	191 (100%)	195 (50-80%)	167 (100%)
Primary Fragment 1	166 (Loss of )	180 (Loss of )	140 (Loss of HCN)
Primary Fragment 2	139 (Loss of HCN from 166)	167 (Loss of /Ethyl)	139 (Loss of H from 140)
Methyl Loss ( )	Absent	Strong Signal (m/z 180)	Absent

## Differentiation Logic

- Check m/z 180: If you see a peak at m/z 180, your sample is contaminated with N-ethylcarbazole. N-ethynylcarbazole cannot generate this fragment.
- Check m/z 167 vs 166:
  - N-Ethylcarbazole produces m/z 167 (protonated carbazole) via Hydrogen rearrangement during ethyl loss.
  - N-Ethynylcarbazole produces m/z 166 (carbazolyl cation) via direct radical loss. The mass difference of 1 Da is critical for high-resolution identification.

## Visualizing the Fragmentation Pathway[1][3][4][5]

The following diagram illustrates the mechanistic flow of fragmentation for N-ethynylcarbazole, highlighting the sequential loss of the alkyne substituent followed by ring degradation.

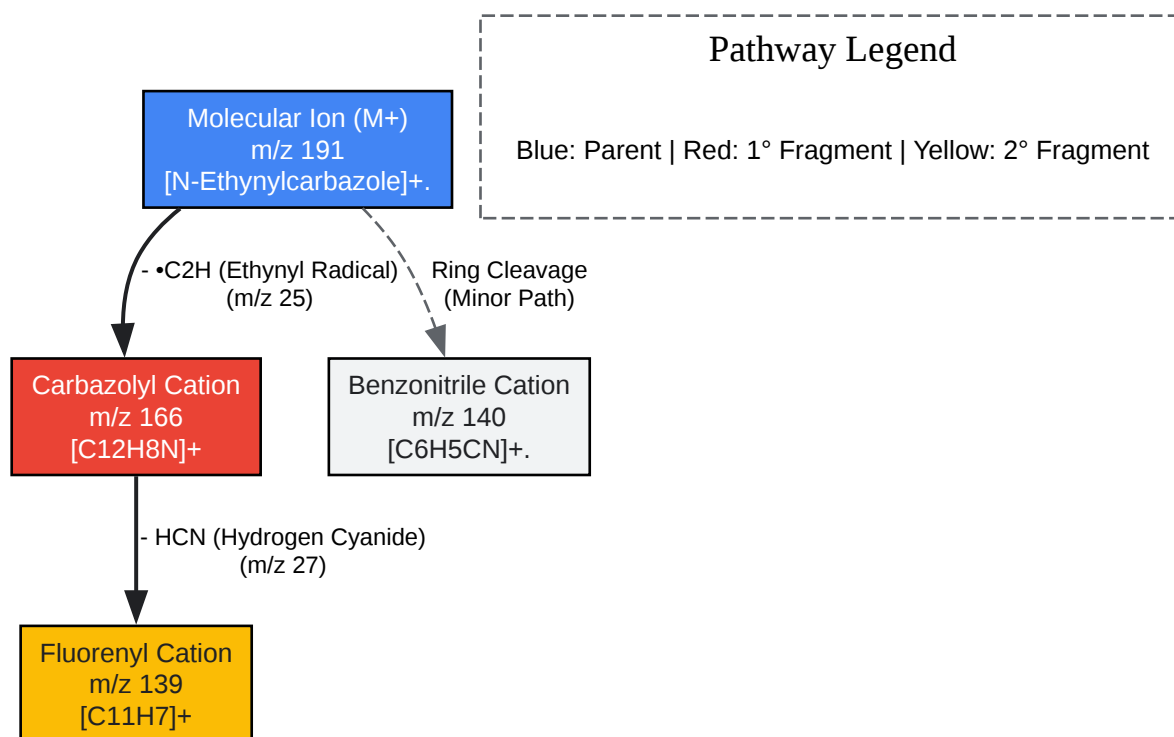

[Click to download full resolution via product page](#)

Caption: Figure 1. Proposed EI-MS fragmentation pathway for N-ethynylcarbazole (m/z 191), showing the characteristic loss of the ethynyl group followed by HCN elimination.

## References

- NIST Mass Spectrometry Data Center. "Mass Spectrum of 9-Ethylcarbazole." NIST Chemistry WebBook, SRD 69. Accessed October 2023. [\[Link\]](#)
- Tabata, H., & Okuno, T. (2012).<sup>[2]</sup> "9-Ethynyl-9H-carbazole."<sup>[2]</sup><sup>[3]</sup><sup>[4]</sup><sup>[5]</sup><sup>[6]</sup> Acta Crystallographica Section E: Structure Reports Online, 68(3), o828.<sup>[2]</sup> [\[Link\]](#)
- Simionescu, C. I., et al. (1977).<sup>[7]</sup> "Synthesis and Properties of Isomeric Poly-N-ethynylcarbazole." Journal of Polymer Science: Polymer Chemistry Edition, 15, 2893-2907. <sup>[7]</sup> [\[Link\]](#)
- ChemGuide. "Fragmentation Patterns in Mass Spectra." ChemGuide UK. [\[Link\]](#)

### Need Custom Synthesis?

BenchChem offers custom synthesis for rare earth carbides and specific isotopic labeling.

Email: [info@benchchem.com](mailto:info@benchchem.com) or [Request Quote Online](#).

## Sources

- [1. whitman.edu \[whitman.edu\]](http://whitman.edu)
- [2. 9-Ethynyl-9H-carbazole - PubMed \[pubmed.ncbi.nlm.nih.gov\]](https://pubmed.ncbi.nlm.nih.gov)
- [3. 9H-Carbazole, 9-ethenyl- | CymitQuimica \[cymitquimica.com\]](http://cymitquimica.com)
- [4. 9H-Carbazole, 9-ethyl- \(CAS 86-28-2\) - Chemical & Physical Properties by Cheméo \[cheméo.com\]](http://cheméo.com)
- [5. N-Vinylcarbazole - Wikipedia \[en.wikipedia.org\]](https://en.wikipedia.org)
- [6. 9-ETHYL-3-ETHYNYL-9H-CARBAZOLE | 102792-38-1 \[chemicalbook.com\]](http://chemicalbook.com)
- [7. revroum.lew.ro \[revroum.lew.ro\]](http://revroum.lew.ro)
- To cite this document: BenchChem. [Comparative Guide: Mass Spectrometry Fragmentation of N-Ethynylcarbazole]. BenchChem, [2026]. [Online PDF]. Available at: [\[https://www.benchchem.com/product/b3350210/docs#comparative-guide-mass-spectrometry-fragmentation-of-n-ethynylcarbazole\]](https://www.benchchem.com/product/b3350210/docs#comparative-guide-mass-spectrometry-fragmentation-of-n-ethynylcarbazole)

---

### Disclaimer & Data Validity:

The information provided in this document is for Research Use Only (RUO) and is strictly not intended for diagnostic or therapeutic procedures. While BenchChem strives to provide accurate protocols, we make no warranties, express or implied, regarding the fitness of this product for every specific experimental setup.

**Technical Support:** The protocols provided are for reference purposes. Unsure if this reagent suits your experiment?

**Need Industrial/Bulk Grade?** [Request Custom Synthesis Quote](#)

# BenchChem

Our mission is to be the trusted global source of essential and advanced chemicals, empowering scientists and researchers to drive progress in science and industry.

## Contact

Address: 3281 E Guasti Rd

Ontario, CA 91761, United States

Phone: (601) 213-4426

Email: [info@benchchem.com](mailto:info@benchchem.com)

[Contact our Ph.D. Support Team for a compatibility check](#)