

# Thermal Dynamics in Synthesis: A Comparative Analysis of Microwave-Assisted vs. Conventional Heating

**Author:** BenchChem Technical Support Team. **Date:** April 2026

## Compound of Interest

Compound Name:	<i>(3-Chloroimidazo[1,2-a]pyridin-6-yl)methanol</i>
CAS No.:	167884-21-1
Cat. No.:	B3348383

[Get Quote](#)

## Executive Summary

For decades, the Bunsen burner and the oil bath defined the kinetic limits of organic synthesis. Today, Microwave-Assisted Organic Synthesis (MAOS) challenges these conventions, offering not just speed, but a fundamental shift in how energy is transferred to molecules.

This guide moves beyond the basic "faster is better" narrative. As application scientists, we analyze the thermodynamic and kinetic distinctions between dielectric heating and conductive heating. We evaluate where microwave irradiation provides a genuine mechanistic advantage—such as in palladium-catalyzed couplings—and where conventional heating remains the superior, scalable choice.

## Mechanistic Underpinnings: Dielectric vs. Conductive Heating[1]

To understand the performance gap, we must first decouple the heating mechanisms. Conventional heating relies on conduction and convection—a slow, "outside-in" process where heat transfers from the vessel wall to the solvent.[1]

Microwave heating utilizes dielectric loss, a phenomenon comprising two primary mechanisms:

- **Dipolar Polarization:** Polar molecules (solvent or reagent) align with the oscillating electric field. As the field alternates (2.45 billion times per second), molecular rotation generates friction and heat.[2]
- **Ionic Conduction:** Dissolved ions oscillate back and forth under the electric field, colliding with neighboring molecules to generate heat.[2][3]

## The "Non-Thermal" Controversy

Senior Scientist Note: You will often hear of "non-thermal microwave effects" (lowering activation energy

). The consensus in high-level physical organic chemistry (championed by C.O. Kappe and others) is that most observed rate accelerations are purely thermal. They arise from Arrhenius rate enhancements due to rapid superheating (heating above the boiling point in sealed vessels) rather than a magic modification of the transition state.

## Visualization: Energy Transfer Pathways

The following diagram contrasts the inefficient thermal gradients of oil baths with the volumetric, selective heating of microwaves.

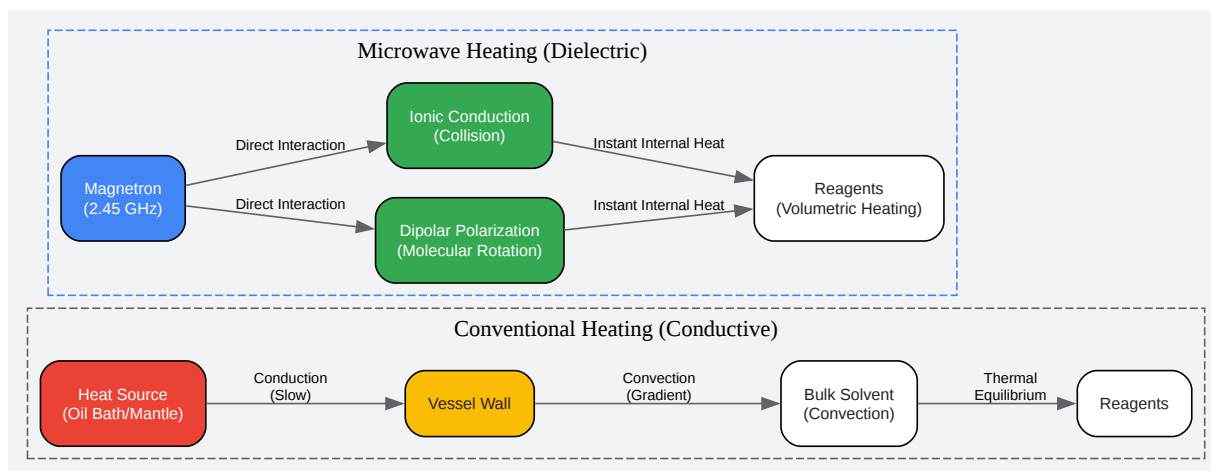

[Click to download full resolution via product page](#)

Figure 1: Comparison of heat transfer vectors. Note that MW bypasses the vessel wall, allowing for 'inverted' temperature gradients where the solution is hotter than the container.

## Performance Metrics Comparison

The following data aggregates typical performance metrics for transition-metal catalyzed cross-coupling reactions (e.g., Suzuki-Miyaura), a class of reactions that benefits significantly from MW heating.

Metric	Conventional Heating (Oil Bath)	Microwave-Assisted (Closed Vessel)	Scientific Rationale
Heating Rate	2–5 °C/min	20–50 °C/min	MW offers volumetric heating; no reliance on thermal conductivity of glass.
Max Temperature	Limited by solvent boiling point ( <a href="#">ngcontent-ng-c2699131324=""</a> _ngghost-ng-c2339441298="" class="inline ng-star-inserted"> )	(up to 300°C)	Sealed vessels allow pressurization (up to 30 bar), enabling "superheating" regimes.
Reaction Time	Hours (2–24 h)	Minutes (5–30 min)	Arrhenius Law: Rate doubles for every 10°C rise. MW reaches higher instantly. <a href="#">[2][4]</a>
Yield	Variable (Thermal degradation possible)	Often Higher	Shorter "thermal history" reduces time for side-product formation.
Energy Efficiency	Low (<10% for small batch)	High (>50% for small batch)	MW heats the sample, not the oil, bath, and surrounding air.
Scalability	High (Linear scale-up)	Low (Penetration depth limits)	MW penetration is limited to ~2–5 cm; requires flow chemistry to scale.

# Experimental Protocol: Rapid Suzuki-Miyaura Coupling

This protocol demonstrates a self-validating workflow for synthesizing biaryls. It contrasts the MW approach with traditional reflux.[5]

Target Reaction: Coupling of 4-bromoanisole and phenylboronic acid to form 4-methoxybiphenyl.

## A. Microwave Protocol (The "High-Speed" Route)

Equipment: Single-mode Microwave Reactor (e.g., CEM Discover or Biotage Initiator). Vessel: 10 mL pressure-rated vial with crimp cap/septum.

- Reagent Loading:
  - Add 4-bromoanisole (1.0 mmol, 187 mg).
  - Add Phenylboronic acid (1.2 mmol, 146 mg).
  - Add Catalyst:  
(0.5 mol%, 5.8 mg). Note: Low catalyst loading is possible due to high turnover frequency at elevated T.
  - Add Base:  
(2.0 mmol, 212 mg).
- Solvent System:
  - Add 3 mL of Ethanol/Water (1:1 v/v).
  - Critical Step (Degassing): Sparge the solvent mixture with Argon for 2 minutes before capping.
  - Why? Oxygen poisons Pd(0) catalysts. While MW is fast, oxidation can still stall the cycle.
- Sealing & Parameters:

- Seal with a Teflon-lined septum.
- Set Point: 120°C.
- Hold Time: 5 minutes.
- Max Pressure: Set safety limit to 250 psi (17 bar).
- Stirring: High (magnetic stir bars can decouple in MW fields; use appropriate size).
- Execution:
  - Ramp time: ~1 min. Reaction time: 5 min. Cooling: ~2 min (compressed air).
- Work-up:
  - Dilute with EtOAc/Water. Extract. Dry over

Result: >95% Conversion in 8 minutes total processing time.

## B. Conventional Protocol (The "Thermal" Route)

- Setup: Round bottom flask, reflux condenser, oil bath pre-heated to 90°C.
- Solvent: Ethanol/Water (1:1).
- Execution: Reflux at ~78°C (boiling point of EtOH).
- Time: Requires 4–6 hours to reach comparable conversion (>90%).

## Data Analysis

The MW protocol achieves in 5 minutes what the oil bath achieves in 4 hours.

- Mechanism: The MW reaction runs at 120°C (42°C above the atmospheric boiling point). According to the Arrhenius equation, a 40°C increase increases the rate by approximately times.

- .
- The experimental result (5 mins) aligns closely with predicted thermal acceleration, validating the "superheating" theory over "magic" non-thermal effects.

## Decision Framework: When to Switch?

Microwave synthesis is not a universal solution.[6] It struggles with scale (batch size > 500 mL) and non-polar solvents (which are transparent to microwaves). Use the following logic to select your method.

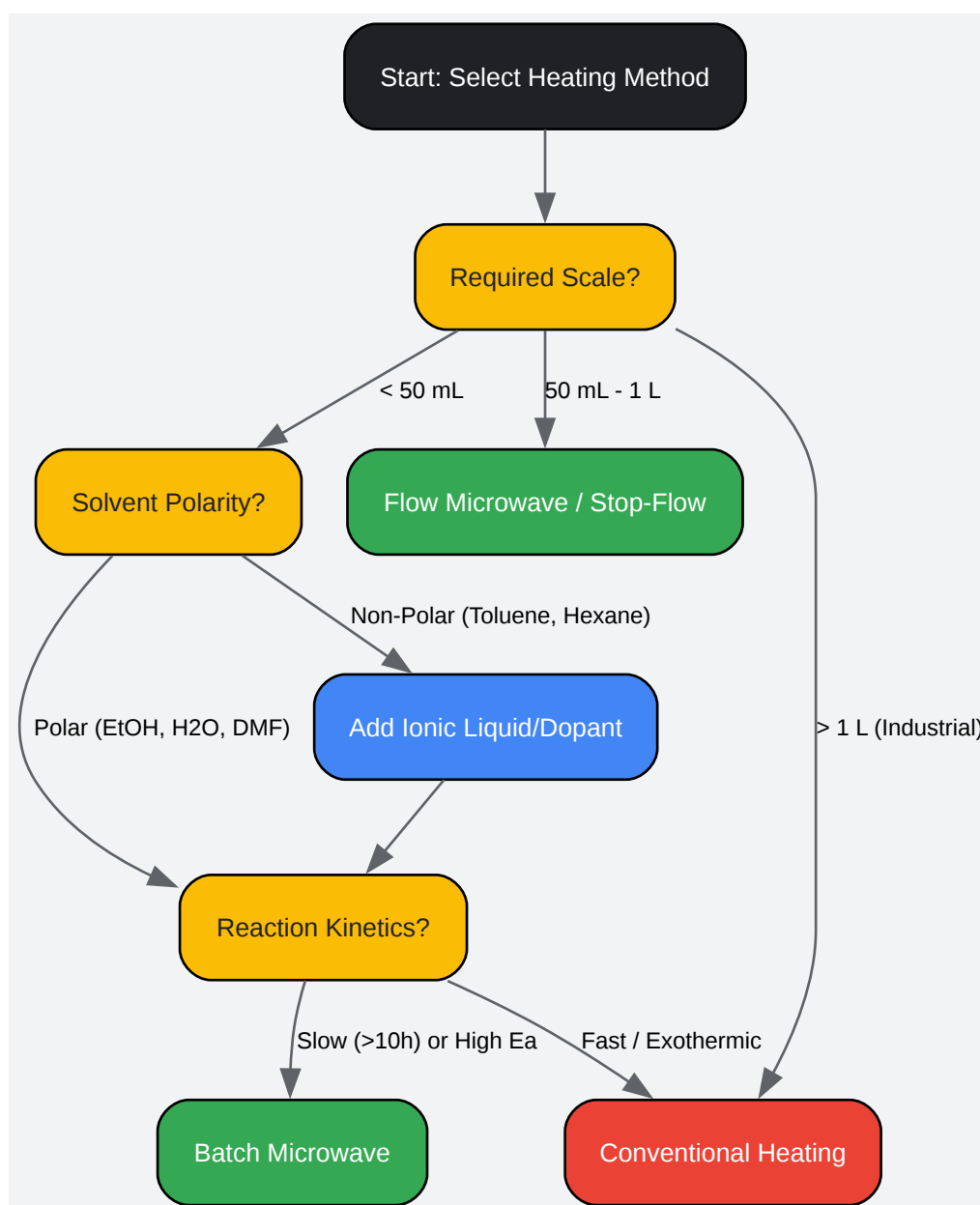

[Click to download full resolution via product page](#)

Figure 2: Strategic decision matrix for method selection. Note that non-polar solvents require "doping" (e.g., adding a small amount of ionic liquid) to absorb microwave energy.

## References

- Kappe, C. O. (2004). "Controlled Microwave Heating in Modern Organic Synthesis." *Angewandte Chemie International Edition*. [Link](#)
- Leadbeater, N. E. (2005). "Fast, Easy, Clean Chemistry by Using Water as a Solvent and Microwave Heating: The Suzuki Coupling as an Illustration." *Journal of Organic Chemistry*. [Link](#)
- Razzaq, T., & Kappe, C. O. (2008). "On the Energy Efficiency of Microwave-Assisted Organic Reactions." *ChemSusChem*. [Link](#)
- Baxendale, I. R., et al. (2006). "Microwave-Assisted Suzuki Coupling Reactions with an Encapsulated Palladium Catalyst." *Synlett*. [Link](#)
- Moseley, J. D., & Kappe, C. O. (2011). "A critical assessment of the scalability of microwave-assisted organic synthesis." *Green Chemistry*. [Link](#)

### *Need Custom Synthesis?*

*BenchChem offers custom synthesis for rare earth carbides and specific isotopic labeling.*

*Email: [info@benchchem.com](mailto:info@benchchem.com) or [Request Quote Online](#).*

## Sources

- 1. [asianjpr.com](http://asianjpr.com) [[asianjpr.com](http://asianjpr.com)]
- 2. [mdpi.com](http://mdpi.com) [[mdpi.com](http://mdpi.com)]
- 3. [researchgate.net](http://researchgate.net) [[researchgate.net](http://researchgate.net)]
- 4. [sphinxesai.com](http://sphinxesai.com) [[sphinxesai.com](http://sphinxesai.com)]
- 5. [wjpr.s3.ap-south-1.amazonaws.com](http://wjpr.s3.ap-south-1.amazonaws.com) [[wjpr.s3.ap-south-1.amazonaws.com](http://wjpr.s3.ap-south-1.amazonaws.com)]

- [6. img.chemicalprocessing.com \[img.chemicalprocessing.com\]](https://img.chemicalprocessing.com)
- To cite this document: BenchChem. [Thermal Dynamics in Synthesis: A Comparative Analysis of Microwave-Assisted vs. Conventional Heating]. BenchChem, [2026]. [Online PDF]. Available at: [<https://www.benchchem.com/product/b3348383/docs#thermal-dynamics-in-synthesis-a-comparative-analysis-of-microwave-assisted-vs-conventional-heating>]

---

### Disclaimer & Data Validity:

The information provided in this document is for Research Use Only (RUO) and is strictly not intended for diagnostic or therapeutic procedures. While BenchChem strives to provide accurate protocols, we make no warranties, express or implied, regarding the fitness of this product for every specific experimental setup.

**Technical Support:** The protocols provided are for reference purposes. Unsure if this reagent suits your experiment?

**Need Industrial/Bulk Grade?** [Request Custom Synthesis Quote](#)

## BenchChem

Our mission is to be the trusted global source of essential and advanced chemicals, empowering scientists and researchers to drive progress in science and industry.

### Contact

Address: 3281 E Guasti Rd  
Ontario, CA 91761, United States  
Phone: (601) 213-4426  
Email: [info@benchchem.com](mailto:info@benchchem.com)

[Contact our Ph.D. Support Team for a compatibility check](#)