

Platform Analytical Method Development for Novel Piperazine Candidates

Author: BenchChem Technical Support Team. **Date:** April 2026

Compound of Interest

Compound Name: *1-(3-Fluoro-4-methylphenyl)piperazine*

CAS No.: 1478-85-9

Cat. No.: B3347950

[Get Quote](#)

Content Type: Application Note & Protocol Guide Version: 2.0 (ICH M10 Compliant)

Abstract

This guide outlines a platform approach for the structural characterization, separation, and quantification of novel piperazine-based compounds (e.g., pharmaceutical candidates or designer analogs). Unlike standard alkyl-amine protocols, piperazines exhibit unique regioisomeric challenges and fragmentation patterns. This document provides a self-validating workflow utilizing Biphenyl stationary phases for isomeric resolution and Mixed-Mode Cation Exchange (MCX) for matrix cleanup, grounded in current ICH M10 regulatory standards.

Structural Elucidation & MS/MS Fragmentation Logic

Before quantification, the specific fragmentation behavior of the piperazine core must be understood to select robust MRM (Multiple Reaction Monitoring) transitions.

The Piperazine Fragmentation Rule

Piperazine derivatives typically ionize in ESI(+) mode due to the basic secondary or tertiary nitrogens (pKa ~9.8). Upon Collision Induced Dissociation (CID), they follow a predictable cleavage pattern essential for identifying novel analogs.

- Mechanism A (Benzylic/Phenyl Cleavage): The bond between the piperazine nitrogen and the aromatic pendant group is the weakest.
 - Example: Benzylpiperazine (BZP) yields a dominant tropylium ion (m/z 91).^[1]
- Mechanism B (Ring Fission): The piperazine ring itself undergoes cross-ring cleavage, often losing neutral ethylene (m/z 28, -28 Da) or imine fragments.
- Mechanism C (Diagnostic Iminium Ions): Phenylpiperazines often generate a characteristic iminium ion at m/z 56 or 70, representing the fragmented piperazine ring attached to the phenyl cation.

Visualization: Fragmentation Pathway

The following diagram illustrates the decision logic for assigning MS/MS transitions for a novel piperazine.

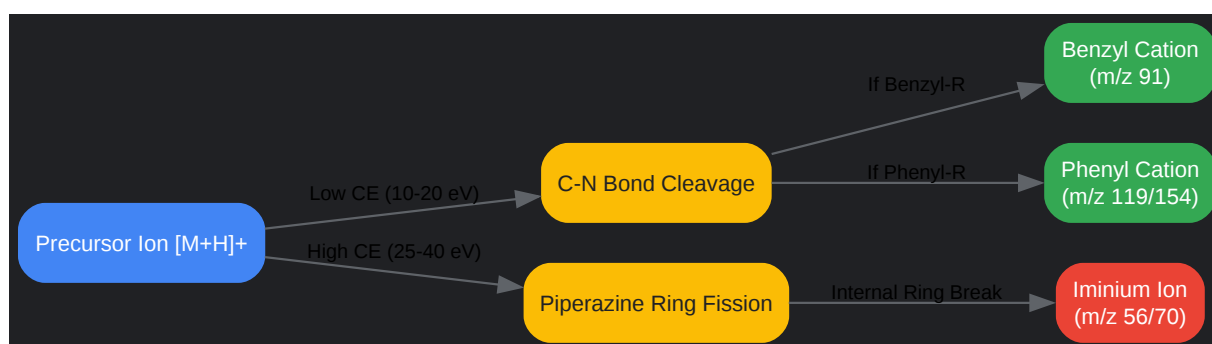

[Click to download full resolution via product page](#)

Figure 1: MS/MS fragmentation logic for selecting Quantifier (Cleavage) and Qualifier (Ring Fission) ions.

Chromatographic Strategy: The Isomer Challenge

Novel piperazines frequently exist as positional isomers (e.g., ortho-, meta-, para- substitutions on the phenyl ring). Standard C18 columns often fail to resolve these isomers due to identical hydrophobicity.

Stationary Phase Selection

- **The Failure of C18:** C18 relies on hydrophobic interaction. Positional isomers (e.g., 3-TFMPP vs. 4-TFMPP) often have identical logP values, resulting in co-elution.
- **The Solution: Biphenyl Phases:** Biphenyl stationary phases possess overlapping aromatic rings. They separate analytes via

interactions and steric selectivity. The spatial arrangement of the isomer dictates how well it "slots" into the biphenyl ligand, providing baseline resolution where C18 fails.

Recommended LC Conditions

Parameter	Setting	Rationale
Column	Biphenyl Core-Shell (2.6 μ m, 100 x 2.1 mm)	Maximizes selectivity for isomers.
Mobile Phase A	Water + 0.1% Formic Acid	Low pH ensures protonation of basic N for MS sensitivity.
Mobile Phase B	Methanol + 0.1% Formic Acid	MeOH promotes stronger interactions than Acetonitrile.
Gradient	5% B to 95% B over 8 min	Slow ramp required to resolve regio-isomers.
Flow Rate	0.4 mL/min	Optimal linear velocity for core-shell particles.

Sample Preparation: Mixed-Mode Cation Exchange (MCX)

Piperazines are basic polar amines. Liquid-Liquid Extraction (LLE) often results in poor recovery due to their water solubility. Solid Phase Extraction (SPE) using Mixed-Mode Cation Exchange is the gold standard, providing a "self-validating" cleanup by utilizing two distinct retention mechanisms (Hydrophobic + Ionic).

MCX Protocol Logic

- **Load (Acidic):** The analyte is protonated (positively charged). It binds to the sorbent's sulfonate groups via ionic exchange.
- **Wash 1 (Acidic/Aqueous):** Removes proteins and salts. Analyte remains locked ionically.
- **Wash 2 (Organic/Neutral):** Removes hydrophobic interferences (lipids). Analyte remains locked ionically.
- **Elute (Basic/Organic):** High pH neutralizes the analyte (removing positive charge), breaking the ionic bond and releasing it into the organic solvent.

Visualization: SPE Workflow

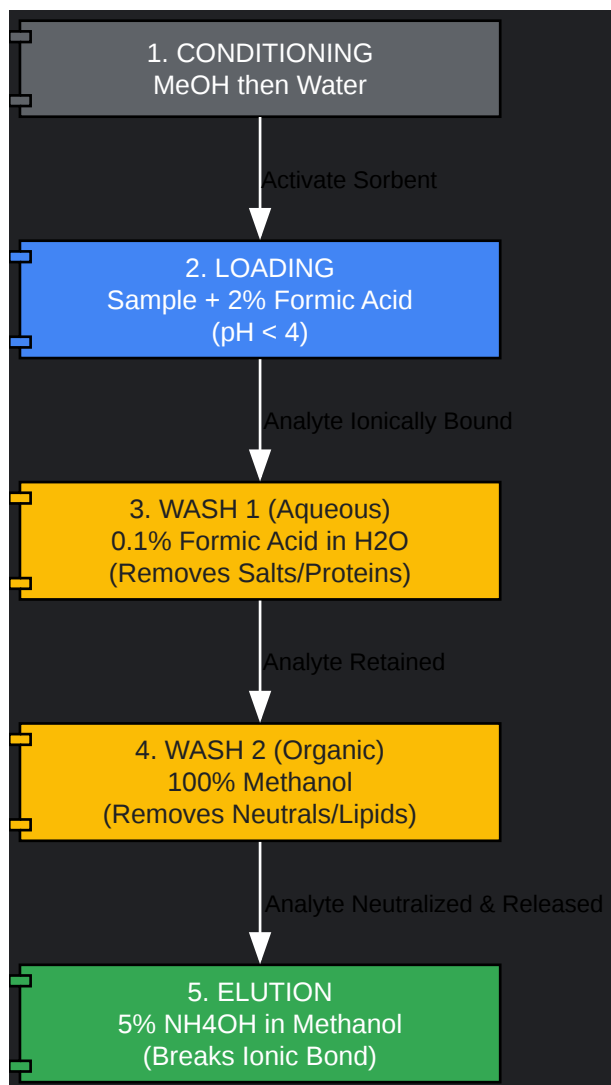

[Click to download full resolution via product page](#)

Figure 2: Mixed-Mode Cation Exchange (MCX) protocol ensuring high specificity for basic piperazines.

Method Validation (ICH M10 Guidelines)

To ensure the method is suitable for regulatory submission, validation must follow the ICH M10 guidelines (Bioanalytical Method Validation).^{[2][3][4][5]}

Key Validation Parameters

- Selectivity: Analyze blank matrix from 6 individual sources. No interference >20% of the LLOQ (Lower Limit of Quantification) area is permitted.

- Matrix Effect (ME):
 - Requirement: The CV of the IS-normalized matrix factor across 6 lots must be <15%.
 - Troubleshooting: If ME is high (>15% suppression), switch from C18 to MCX SPE (as described above) to remove phospholipids.
- Carryover: Inject a blank after the ULOQ (Upper Limit of Quantification) standard. Carryover must be <20% of LLOQ.
- Accuracy & Precision:
 - Within-run and Between-run CV% must be

(20% for LLOQ).

Stability Assessment

Novel piperazines may be light-sensitive or unstable in basic plasma.

- Bench-top Stability: 4 hours at room temperature.
- Freeze-Thaw: 3 cycles from -20°C to RT.
- Processed Sample Stability: 24 hours in the autosampler (verify no degradation of the imine ring).

References

- International Council for Harmonisation (ICH). (2022). M10 Bioanalytical Method Validation and Study Sample Analysis. [[Link](#)]
- Restek Corporation. (2017). Evaluation of Retention and Selectivity Using Biphenyl Stationary Phases. [[Link](#)]
- United Nations Office on Drugs and Crime (UNODC). (2013). Recommended Methods for the Identification and Analysis of Piperazines in Seized Materials. [[Link](#)]

- National Institutes of Health (NIH). (2022). Comparison of LC-MS and LC-DAD Methods of Detecting Abused Piperazine Designer Drugs. [[Link](#)]

Need Custom Synthesis?

BenchChem offers custom synthesis for rare earth carbides and specific isotopic labeling.

Email: info@benchchem.com or [Request Quote Online](#).

Sources

- 1. Mass Fragmentation Characteristics of Piperazine Analogues [zpxb.xml-journal.net]
- 2. database.ich.org [database.ich.org]
- 3. ICH M10 on bioanalytical method validation - Scientific guideline | European Medicines Agency (EMA) [ema.europa.eu]
- 4. ema.europa.eu [ema.europa.eu]
- 5. ICH M10 Guideline on Bioanalytical Method Validation and Study Sample Analysis - ECA Academy [gmp-compliance.org]
- To cite this document: BenchChem. [Platform Analytical Method Development for Novel Piperazine Candidates]. BenchChem, [2026]. [Online PDF]. Available at: [<https://www.benchchem.com/product/b3347950/docs#platform-analytical-method-development-for-novel-piperazine-candidates>]

Disclaimer & Data Validity:

The information provided in this document is for Research Use Only (RUO) and is strictly not intended for diagnostic or therapeutic procedures. While BenchChem strives to provide accurate protocols, we make no warranties, express or implied, regarding the fitness of this product for every specific experimental setup.

Technical Support: The protocols provided are for reference purposes. Unsure if this reagent suits your experiment?

Need Industrial/Bulk Grade? [Request Custom Synthesis Quote](#)

BenchChem

Our mission is to be the trusted global source of essential and advanced chemicals, empowering scientists and researchers to drive progress in science and industry.

Contact

Address: 3281 E Guasti Rd
Ontario, CA 91761, United States
Phone: (601) 213-4426
Email: info@benchchem.com

[Contact our Ph.D. Support Team for a compatibility check](#)