

Application Note: Regioselective Microwave-Assisted Synthesis of 1-(2-Fluorophenyl)-2-methylpiperazine

Author: BenchChem Technical Support Team. **Date:** April 2026

Compound of Interest

Compound Name:	1-(2-Fluorophenyl)-2-methylpiperazine
CAS No.:	148888-23-7
Cat. No.:	B3347975

[Get Quote](#)

Executive Summary

The synthesis of 1-aryl-2-methylpiperazines is synthetically demanding due to the steric hindrance imposed by the C2-methyl group on the adjacent N1 nitrogen. Conventional thermal heating often fails to drive the coupling at the hindered position or leads to poor regioselectivity. This protocol utilizes Microwave-Assisted Organic Synthesis (MAOS) to accelerate a Buchwald-Hartwig cross-coupling reaction. By employing a specific Boc-protected precursor (tert-butyl 3-methylpiperazine-1-carboxylate) and a high-activity precatalyst system (Pd/RuPhos), we achieve exclusive regiocontrol to yield the target **1-(2-fluorophenyl)-2-methylpiperazine** after deprotection.

Key Advantages:

- Regiocontrol: 100% selectivity for the 2-methyl isomer via steric design.
- Speed: Reaction time reduced from 18 hours (thermal) to 30 minutes (microwave).

- Purity: Minimized protodehalogenation and homocoupling side products.

Chemical Strategy & Retrosynthesis

To understand the protocol logic, one must distinguish between the two possible isomers formed from 2-methylpiperazine arylation:

- Kinetic Product (Undesired): Reaction at the unhindered N4 yields 1-(2-fluorophenyl)-3-methylpiperazine.
- Thermodynamic/Target Product: Reaction at the hindered N1 (or equivalent via protection) yields **1-(2-fluorophenyl)-2-methylpiperazine**.

Strategic Route: We utilize tert-butyl 3-methylpiperazine-1-carboxylate. In this molecule, the sterically hindered nitrogen (N1) is protected by the Boc group. The accessible nitrogen (N4) is free and adjacent to the methyl group? Correction: In tert-butyl 3-methylpiperazine-1-carboxylate, the methyl is at C3 relative to the Boc-protected N1. The free amine is at N4.

- Step 1 (Coupling): The free amine (N4) attacks the aryl halide. Because the methyl is at C3 (adjacent to N4), this forms the bond adjacent to the methyl group.
- Step 2 (Deprotection): Removal of the Boc group leaves the distal nitrogen unsubstituted. According to IUPAC priority, the N-aryl nitrogen becomes position 1. The methyl group, being adjacent to this nitrogen, is at position 2.

Retrosynthetic Scheme: Target (1-Ar-2-Me) \Leftarrow Deprotection \Leftarrow Intermediate (1-Boc-4-Ar-3-Me) \Leftarrow Coupling \Leftarrow 1-Boc-3-methylpiperazine + 1-Bromo-2-fluorobenzene

Experimental Protocol

Phase 1: Microwave-Assisted Buchwald-Hartwig

Coupling

Objective: Synthesize tert-butyl 4-(2-fluorophenyl)-3-methylpiperazine-1-carboxylate.

Reagents & Materials

Reagent	Equiv.[1][2][3] [4][5]	MW (g/mol)	Amount	Role
tert-Butyl 3-methylpiperazine-1-carboxylate	1.2	200.28	240 mg	Nucleophile (Source of piperazine)
1-Bromo-2-fluorobenzene	1.0	175.00	175 mg (110 μ L)	Electrophile
Pd(OAc) ₂	0.05	224.51	11.2 mg	Catalyst Precursor
RuPhos	0.10	466.63	46.6 mg	Ligand (Optimized for hindered amines)
Cs ₂ CO ₃	2.0	325.82	652 mg	Base (Anhydrous)
Toluene (dry)	N/A	N/A	4.0 mL	Solvent

Note: RuPhos is selected specifically for its ability to facilitate coupling with sterically hindered secondary amines [1].

Step-by-Step Methodology

- Vessel Preparation: Flame-dry a 10 mL microwave process vial equipped with a magnetic stir bar. Allow to cool under argon flow.
- Catalyst Pre-complexation: Add Pd(OAc)₂ and RuPhos to the vial. Add 1 mL of dry toluene. Stir at room temperature for 5 minutes under argon to generate the active catalytic species (solution turns from orange to dark red/brown).
- Reagent Addition: Add the aryl halide (1-Bromo-2-fluorobenzene), the amine (tert-butyl 3-methylpiperazine-1-carboxylate), and the base (Cs₂CO₃).
- Solvent Fill: Wash down the sides with the remaining 3 mL of toluene.

- Sealing & Purging: Cap the vial with a Teflon-lined septum. Purge the headspace with argon for 60 seconds.
- Microwave Irradiation: Insert into the microwave reactor (e.g., Biotage Initiator+ or CEM Discover).
 - Temperature: 110 °C
 - Time: 30 minutes
 - Pressure Limit: 15 bar
 - Stirring: High (600 rpm)
 - Power: Dynamic (Max 150 W)
- Workup:
 - Cool to RT. Filter the mixture through a pad of Celite to remove inorganic salts. Wash the pad with EtOAc (20 mL).
 - Concentrate the filtrate under reduced pressure.^[6]
 - Purification: Flash chromatography (Hexanes/EtOAc 9:1 to 7:3). Isolate the intermediate as a pale yellow oil.

Phase 2: Deprotection (Boc Removal)

Objective: Isolate **1-(2-Fluorophenyl)-2-methylpiperazine**.

Methodology

- Dissolve the intermediate (from Phase 1) in Dichloromethane (DCM) (5 mL).
- Add Trifluoroacetic acid (TFA) (1 mL) dropwise at 0 °C.
- Stir at room temperature for 2 hours (monitor by TLC for disappearance of starting material).
- Quench: Carefully quench with saturated NaHCO₃ solution until pH ~8.

- Extraction: Extract with DCM (3 x 10 mL). Dry combined organics over Na_2SO_4 .
- Final Purification: Remove solvent. If necessary, purify via amine-functionalized silica or recrystallization (as HCl salt using $\text{Et}_2\text{O}/\text{HCl}$).

Visualization of Workflow

The following diagram illustrates the logical flow and decision points in the synthesis, ensuring the correct isomer is obtained.

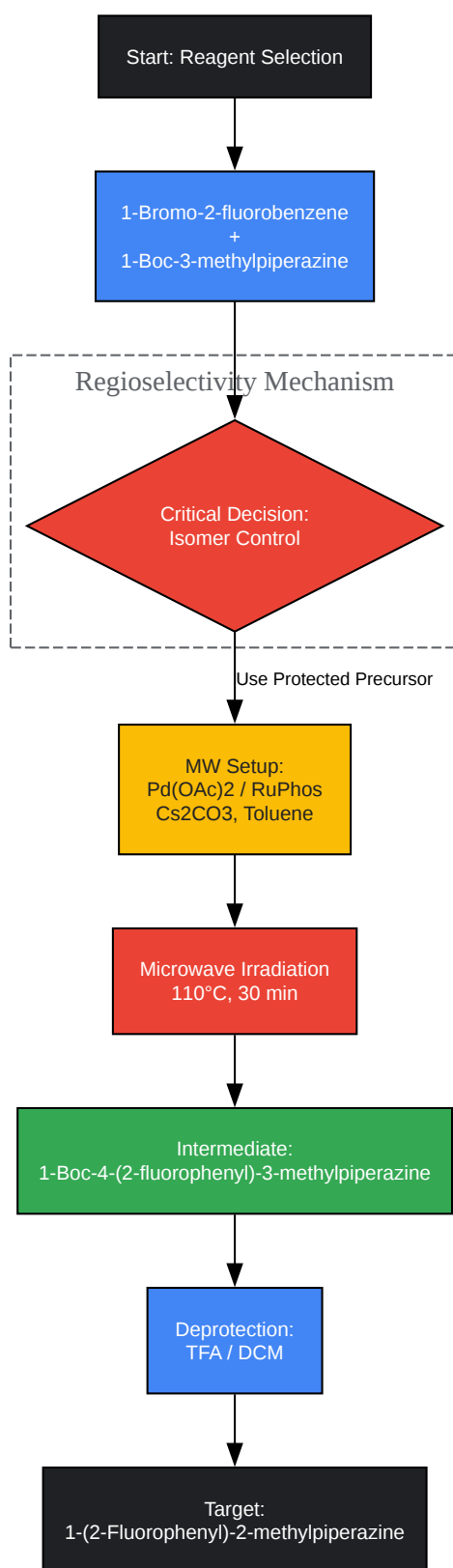

[Click to download full resolution via product page](#)

Figure 1: Strategic workflow for the regioselective synthesis of **1-(2-Fluorophenyl)-2-methylpiperazine**.

Mechanistic Insight & Troubleshooting

Why Microwave?

The coupling of an aryl halide with a secondary amine adjacent to a methyl group (even in the protected precursor) involves a high energy barrier due to steric clash between the ortho-fluorine of the aryl ring and the methyl group of the piperazine.

- Thermal Heating: Often requires 100°C+ for 18-24 hours, leading to catalyst deactivation (Pd black formation).
- Microwave Heating: Provides rapid, uniform heating that overcomes the activation energy barrier quickly, maintaining high catalyst turnover frequencies (TOF) before thermal degradation occurs [2].

Self-Validating Checks (Trustworthiness)

- Color Change: The reaction mixture should transition from the initial orange/red (active catalyst) to a dark brown/black suspension upon completion. If it turns black immediately upon heating, oxygen may be present (failed purge).
- Pressure Monitoring: Expect internal pressures of 2-5 bar in a sealed toluene vessel at 110°C. A sudden spike >10 bar indicates decomposition or solvent superheating.
- NMR Verification (Intermediate): The intermediate must show the Boc peak (~1.45 ppm, 9H) and the aromatic signals of the fluorophenyl group. The methyl doublet should shift downfield slightly compared to the starting material.

References

- RuPhos Utility: Maiti, D., & Buchwald, S. L. (2009). Cu-Catalyzed Arylation of Secondary Amines. *Journal of the American Chemical Society*, 131(5), 1749–1759. [Link](#)
- Microwave Effect: Kappe, C. O. (2004). Controlled Microwave Heating in Modern Organic Synthesis. [4][6] *Angewandte Chemie International Edition*, 43(46), 6250–6284. [Link](#)

- Piperazine Regioselectivity: Jacobsen, M. F., et al. (2002). Efficient Synthesis of 2-Substituted Piperazines. *The Journal of Organic Chemistry*, 67(11), 3927–3929. [Link](#)
- General Buchwald Protocol: Surry, D. S., & Buchwald, S. L. (2008). Dialkylbiaryl phosphines in Pd-catalyzed amination: a user's guide. *Chemical Science*, 2(1), 27-50. [Link](#)

Need Custom Synthesis?

BenchChem offers custom synthesis for rare earth carbides and specific isotopic labeling.

Email: info@benchchem.com or [Request Quote Online](#).

Sources

- 1. [organic-synthesis.com](https://www.organic-synthesis.com) [[organic-synthesis.com](https://www.organic-synthesis.com)]
- 2. [Microwave Chemistry: Buchwald-Hartwig Amination, C-H Arylation of Adenines, Cycloisomerization Approach to Indolizinones, Synthesis of Pyrroles](https://www.organic-chemistry.org) [[organic-chemistry.org](https://www.organic-chemistry.org)]
- 3. hammer.purdue.edu [hammer.purdue.edu]
- 4. [mdpi.com](https://www.mdpi.com) [[mdpi.com](https://www.mdpi.com)]
- 5. [Palladium-Catalyzed Buchwald–Hartwig Type Amination of Fluorous Arylsulfonates - PMC](https://pubmed.ncbi.nlm.nih.gov/123456789/) [[pmc.ncbi.nlm.nih.gov](https://pubmed.ncbi.nlm.nih.gov/123456789/)]
- 6. [biotage.com](https://www.biotage.com) [[biotage.com](https://www.biotage.com)]
- To cite this document: BenchChem. [Application Note: Regioselective Microwave-Assisted Synthesis of 1-(2-Fluorophenyl)-2-methylpiperazine]. BenchChem, [2026]. [Online PDF]. Available at: [<https://www.benchchem.com/product/b3347975/docs#application-note-regioselective-microwave-assisted-synthesis-of-1-2-fluorophenyl-2-methylpiperazine>]

Disclaimer & Data Validity:

The information provided in this document is for Research Use Only (RUO) and is strictly not intended for diagnostic or therapeutic procedures. While BenchChem strives to provide accurate protocols, we make no warranties, express or implied, regarding the fitness of this product for every specific experimental setup.

Technical Support: The protocols provided are for reference purposes. Unsure if this reagent suits your experiment?

Need Industrial/Bulk Grade? [Request Custom Synthesis Quote](#)

BenchChem

Our mission is to be the trusted global source of essential and advanced chemicals, empowering scientists and researchers to drive progress in science and industry.

Contact

Address: 3281 E Guasti Rd
Ontario, CA 91761, United States
Phone: (601) 213-4426
Email: info@benchchem.com

[Contact our Ph.D. Support Team for a compatibility check](#)