

"performance evaluation of cyclopentanedecol-based polymers"

Author: BenchChem Technical Support Team. **Date:** April 2026

Compound of Interest

Compound Name: Cyclopentanedecol

CAS No.: 595-03-9

Cat. No.: B3344100

[Get Quote](#)

Performance Evaluation of **Cyclopentanedecol**-Derived Polyquinoxaline Polymers in High-Energy Organic Cathodes

As the demand for sustainable, high-capacity energy storage systems intensifies, organic rechargeable batteries have emerged as a compelling alternative to transition-metal-oxide cathodes. However, the field has historically been bottlenecked by the high solubility of organic active materials in liquid electrolytes and their poor intrinsic electrical conductivity.

To overcome these limitations, our application engineering focus has shifted toward extended

-conjugated heteroaromatic networks. Specifically, polymers derived from **cyclopentanedecol**—a stable, biomass-derivable geminal diol—have demonstrated unprecedented multi-electron redox capabilities. This guide provides an objective performance evaluation of **Cyclopentanedecol**-Derived Polyquinoxaline (CPQ) polymers, comparing them against industry-standard organic alternatives, and details the self-validating experimental protocols required for their synthesis and electrochemical characterization.

Mechanistic Grounding: The Role of Cyclopentanedecol

Cyclopentanedecol (decahydroxycyclopentane,

) is the stable, fivefold hydrate of the highly reactive oxocarbon cyclopentanepentone (

) [1]. Because isolated cyclopentanepentone is prone to rapid degradation, **cyclopentanedecol** serves as the ideal bench-stable precursor [2].

During synthesis, in situ thermal dehydration of **cyclopentanedecol** yields the reactive oxocarbon, which immediately undergoes a Schiff-base condensation reaction with a diamine (e.g., o-phenylenediamine or 1,2,4,5-benzenetetramine). This yields an extended

-conjugated polyquinoxaline network (CPQ). The causality behind this specific structural design is twofold:

- Multi-Electron Transfer: The resulting electron-deficient pyrazine sites allow for the reversible accommodation of multiple lithium ions () per monomer unit, drastically increasing specific capacity [3].
- Insolubility via Conjugation: The rigid, extended polymeric backbone prevents the dissolution of the active material into the electrolyte, effectively solving the capacity-fading issue that plagues small-molecule organic cathodes [4].



[Click to download full resolution via product page](#)

Diagram 1: Mechanistic pathway from **cyclopentanedecol** to multi-electron lithiation.

Comparative Performance Analysis

To establish an objective baseline, we evaluate CPQ against two extensively studied organic cathode materials:

- PTMA (Poly(2,2,6,6-tetramethylpiperidinyloxy-4-yl methacrylate)): A radical polymer known for ultra-fast reaction kinetics but limited by a single-electron transfer mechanism (low theoretical capacity).
- PANI (Polyaniline): A traditional conductive polymer relying on anion doping/dedoping, which suffers from structural degradation over extended cycling.

Quantitative Data Summary

Material	Redox Mechanism	Theoretical Capacity (mAh/g)	Practical Capacity at 1C (mAh/g)	Redox Potential (V vs Li/Li ⁺)	Capacity Retention (1000 cycles)
CPQ Polymer	Multi-electron (Pyrazine)	~400	~395	2.15 – 2.95	> 96.0%
PTMA	Single-electron (Nitroxide)	111	~105	~ 3.60	~ 85.0%
PANI	Anion doping (Amine/Imine)	~140	~120	~ 3.00	< 80.0%

Analysis: While PTMA offers a higher redox voltage, its capacity is fundamentally capped by its single-electron nitroxide radical chemistry. CPQ bypasses this limitation by utilizing multiple pyrazine nitrogen centers, achieving nearly four times the practical capacity of PTMA while maintaining exceptional cycle life due to its robust, insoluble

-conjugated framework [3].

Self-Validating Experimental Protocols

As a Senior Application Scientist, I emphasize that a protocol is only as good as its internal validation mechanisms. The following workflows are designed to be self-validating, ensuring that intermediate failures are caught before downstream testing.

Protocol A: Synthesis of CPQ Polymer

Objective: Convert **cyclopentanedecol** into an insoluble, redox-active polyquinoxaline network.

- Dehydration & Activation: Suspend 10 mmol of **cyclopentanedecol** in 50 mL of glacial acetic acid under an argon atmosphere.
 - Causality: Acetic acid acts simultaneously as a solvent, a dehydrating agent to strip the geminal hydroxyls (forming cyclopentanepentone), and an acid catalyst for the subsequent Schiff-base formation.
- Condensation: Slowly add 10 mmol of 1,2,4,5-benzenetetramine dropwise to the heated solution (80°C). Reflux the mixture for 24 hours.
- Purification: Filter the resulting dark precipitate and wash sequentially with hot ethanol, deionized water, and acetone to remove unreacted monomers and oligomers. Dry under vacuum at 120°C for 12 hours.
- Validation Check (Self-Validation): Attempt to dissolve a 5 mg sample of the product in N-Methyl-2-pyrrolidone (NMP). Complete insolubility confirms the successful formation of a highly cross-linked, extended polymeric network. FT-IR spectroscopy must show the disappearance of the broad -OH stretch ($\sim 3300\text{ cm}^{-1}$) and the appearance of a sharp C=N stretch ($\sim 1650\text{ cm}^{-1}$).

Protocol B: Electrochemical Cell Fabrication and Evaluation

Objective: Assess the multi-electron redox kinetics and cycle life.

- Slurry Preparation: Grind the CPQ polymer (60 wt%), few-layer graphene (30 wt%), and polyvinylidene fluoride (PVDF, 10 wt%) in NMP to form a homogenous slurry.
 - Causality: Because CPQ has limited intrinsic electronic conductivity, graphene is strictly required to bridge the insulating gaps, ensuring that all pyrazine redox centers are electrochemically accessible.
- Electrode Coating: Cast the slurry onto an aluminum foil current collector and dry in a vacuum oven at 100°C for 12 hours. Punch into 12 mm circular disks.

- Cell Assembly: In an argon-filled glovebox, assemble CR2032 coin cells using a lithium metal anode, a glass fiber separator, and an ether-based electrolyte (1M LiTFSI in DOL/DME, 1:1 v/v).
 - Causality: Ether-based electrolytes are chosen over standard carbonate electrolytes (like EC/DEC) because carbonates are highly susceptible to nucleophilic attack by the reduced organic radical intermediates, which would artificially degrade the cycle life [3].
- Validation Check (Self-Validation): Run Cyclic Voltammetry (CV) at 0.1 mV/s. The appearance of two distinct, highly reversible redox peak pairs (e.g., 2.6/2.15 V and 1.68/1.38 V) validates the multi-electron transfer mechanism. If the peaks shift significantly after the first cycle, the polymer is either dissolving or reacting with the electrolyte.

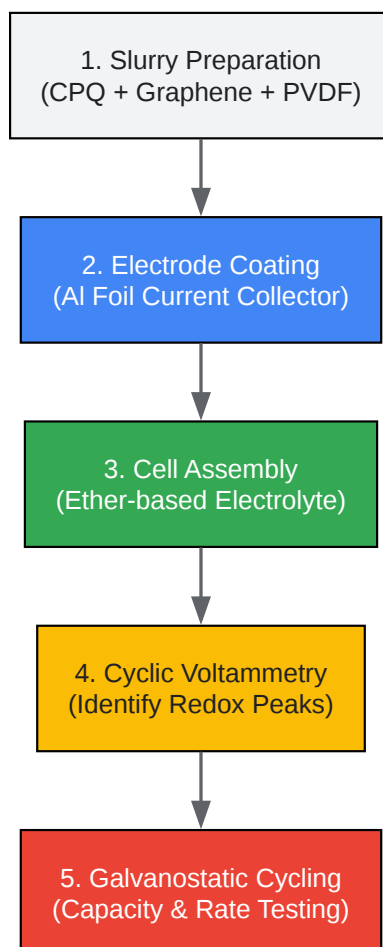

[Click to download full resolution via product page](#)

Diagram 2: Self-validating workflow for electrochemical evaluation of CPQ cathodes.

References

- Wikipedia Contributors. (2024). Decahydroxycyclopentane. Wikipedia, The Free Encyclopedia. Available at: [\[Link\]](#)
- National Center for Biotechnology Information. (2024). PubChem Compound Summary for CID 12305029, **Cyclopentanedecol**. PubChem. Available at:[\[Link\]](#)
- Peng, C., Ning, G., Su, J., et al. (2017). Reversible multi-electron redox chemistry of π -conjugated N-containing heteroaromatic molecule-based organic cathodes. Nature Energy, 2, 17074. Available at: [\[Link\]](#)

Need Custom Synthesis?

BenchChem offers custom synthesis for rare earth carbides and specific isotopic labeling.

Email: info@benchchem.com or [Request Quote Online](#).

Sources

- [1. Decahydroxycyclopentane - Wikipedia \[en.wikipedia.org\]](#)
- [2. Cyclopentanedecol | C5H10O10 | CID 12305029 - PubChem \[pubchem.ncbi.nlm.nih.gov\]](#)
- [3. carbonlab.science.nus.edu.sg \[carbonlab.science.nus.edu.sg\]](#)
- [4. thieme-connect.com \[thieme-connect.com\]](#)
- To cite this document: BenchChem. ["performance evaluation of cyclopentanedecol-based polymers"]. BenchChem, [2026]. [Online PDF]. Available at: [\[https://www.benchchem.com/product/b3344100/docs#performance-evaluation-of-cyclopentanedecol-based-polymers\]](https://www.benchchem.com/product/b3344100/docs#performance-evaluation-of-cyclopentanedecol-based-polymers)

Disclaimer & Data Validity:

The information provided in this document is for Research Use Only (RUO) and is strictly not intended for diagnostic or therapeutic procedures. While BenchChem strives to provide accurate protocols, we make no warranties, express or implied, regarding the fitness of this product for every specific experimental setup.

Technical Support: The protocols provided are for reference purposes. Unsure if this reagent suits your experiment?

Need Industrial/Bulk Grade? [Request Custom Synthesis Quote](#)

BenchChem

Our mission is to be the trusted global source of essential and advanced chemicals, empowering scientists and researchers to drive progress in science and industry.

Contact

Address: 3281 E Guasti Rd
Ontario, CA 91761, United States
Phone: (601) 213-4426
Email: info@benchchem.com

[Contact our Ph.D. Support Team for a compatibility check](#)