

# A Senior Application Scientist's Guide to Validating Diazepinone Regioisomers Using NOESY

**Author:** BenchChem Technical Support Team. **Date:** April 2026

## Compound of Interest

Compound Name:	1,3,4,7-Tetrahydro-1,3-diazepin-2-one
CAS No.:	72331-40-9
Cat. No.:	B3344455

[Get Quote](#)

In the landscape of drug discovery and development, the unambiguous structural elucidation of synthesized molecules is a cornerstone of success. For heterocyclic compounds like diazepinones, which are prevalent scaffolds in medicinal chemistry, the potential for regioisomerism presents a significant analytical challenge.<sup>[1]</sup> An incorrect assignment of a substituent's position on the diazepinone core can lead to misinterpreted structure-activity relationships (SAR), wasted resources, and potential safety concerns. This guide provides an in-depth, experience-driven comparison of using Nuclear Overhauser Effect Spectroscopy (NOESY) to definitively validate the structure of diazepinone regioisomers, a technique superior to more common 2D NMR experiments like COSY for this specific purpose.

## The Challenge: Why Distinguishing Diazepinone Regioisomers is Critical

Diazepinones are seven-membered heterocyclic rings containing two nitrogen atoms and a carbonyl group.<sup>[1][2]</sup> The synthesis of substituted diazepinones can often lead to the formation

of multiple regioisomers, where substituents are attached to different positions on the core ring structure.<sup>[2]</sup> While techniques like 1D proton and carbon NMR, and even 2D COSY (Correlation Spectroscopy), are invaluable for determining the overall carbon framework and proton-proton coupling networks, they often fall short in distinguishing between regioisomers.<sup>[3]</sup><sup>[4]</sup><sup>[5]</sup> This is because through-bond correlations (as seen in COSY) may be identical or ambiguous between two regioisomeric structures.

The Nuclear Overhauser Effect (NOE) provides a powerful solution. The NOE is a through-space phenomenon where the magnetization of one nucleus is affected by the saturation of a nearby nucleus.<sup>[6]</sup><sup>[7]</sup><sup>[8]</sup> This effect is exquisitely sensitive to the distance between nuclei, typically observable for protons within 4-5 Å of each other, and its magnitude is inversely proportional to the sixth power of this distance.<sup>[7]</sup><sup>[8]</sup> A 2D NOESY experiment maps these through-space correlations, providing a clear picture of which protons are in close spatial proximity, thereby allowing for the confident assignment of a molecule's three-dimensional structure and, crucially, its regiochemistry.<sup>[6]</sup><sup>[9]</sup>

## Case Study: Differentiating Two Hypothetical Diazepinone Regioisomers

To illustrate the power of NOESY, let's consider a hypothetical synthesis that could yield two distinct diazepinone regioisomers, Regioisomer A and Regioisomer B.

**Hypothetical Synthesis:** A plausible route to a substituted diazepinone could involve the condensation of a substituted o-phenylenediamine with a  $\beta$ -keto ester. Depending on the electronic and steric nature of the substituents on the diamine, the initial cyclization could occur in two different ways, leading to the formation of two possible regioisomers.

For our case study, let's assume the synthesis could produce either a 2-methyl-4-phenyl-1,5-benzodiazepin-2-one (Regioisomer A) or a 4-methyl-2-phenyl-1,5-benzodiazepin-4-one (Regioisomer B). While other NMR techniques might struggle to differentiate these two, NOESY provides a clear path to validation.

## The Decisive Power of NOESY: Expected Correlations

The key to differentiating Regioisomer A and Regioisomer B lies in identifying unique through-space interactions that are only possible in one isomer.

- For Regioisomer A (2-methyl-4-phenyl): We would expect to see a strong NOE correlation between the protons of the methyl group at position 2 and the protons of the adjacent methylene group at position 3. Additionally, a crucial NOE would be observed between the protons of the phenyl group at position 4 and the proton on the imine carbon at position 3.
- For Regioisomer B (4-methyl-2-phenyl): In this isomer, the methyl group is now at position 4. Therefore, a key NOE correlation would be expected between the protons of this methyl group and the aromatic protons on the fused benzene ring. Conversely, the phenyl group at position 2 would show an NOE correlation with the protons of the adjacent methylene group at position 3.

These distinct and predictable NOE patterns provide an unambiguous method for assigning the correct structure.

## Experimental Workflow and Data Interpretation

The following provides a logical workflow for acquiring and interpreting NOESY data for the validation of diazepinone regioisomers.

Figure 1. A generalized workflow for the synthesis, purification, and structural validation of diazepinone regioisomers using NMR spectroscopy, culminating in NOESY analysis.

## Detailed Experimental Protocol for 2D NOESY

This protocol is a self-validating system, ensuring high-quality data for unambiguous structural assignment.

- Sample Preparation:
  - Dissolve 5-10 mg of the purified diazepinone regioisomer in 0.5-0.6 mL of a deuterated solvent (e.g., CDCl<sub>3</sub>, DMSO-d<sub>6</sub>). The choice of solvent should be based on the solubility of the compound and should ideally provide good signal dispersion in the <sup>1</sup>H NMR spectrum.

- Filter the solution through a small plug of glass wool into a clean, high-quality NMR tube to remove any particulate matter.
- Expert Insight: The concentration should be optimized to obtain a good signal-to-noise ratio in a reasonable number of scans.[\[10\]](#) Excessively high concentrations can lead to line broadening and may dampen the NOE effect.[\[11\]](#)
- Initial 1D  $^1\text{H}$  NMR Acquisition:
  - Acquire a standard 1D  $^1\text{H}$  NMR spectrum to verify the sample's purity and to determine the chemical shift range of the protons.
  - Optimize shimming to obtain sharp, symmetrical peaks. Good shimming is crucial for high-quality 2D NMR data.[\[11\]](#)
  - Trustworthiness Check: The line width of a well-shimmed, non-exchanging proton signal should be less than 0.5 Hz.
- 2D NOESY Parameter Setup:
  - Use a standard NOESY pulse sequence (e.g., noesyegp on Bruker instruments).
  - Spectral Width (SW): Set the spectral width in both dimensions to encompass all proton signals.
  - Mixing Time (d8): This is a critical parameter. For small molecules like diazepam, a mixing time of 600-1000 ms is generally a good starting point.[\[12\]](#) It may be necessary to run a few experiments with different mixing times to optimize the NOE buildup.[\[13\]](#)
  - Number of Scans (NS): A sufficient number of scans (typically 8, 16, or 32 per increment) should be used to achieve an adequate signal-to-noise ratio for the weak NOE cross-peaks.[\[10\]](#)[\[11\]](#)
  - Acquisition Time (AQ) and Number of Increments (TD in F1): These parameters determine the resolution in the direct and indirect dimensions, respectively. A balance must be struck between resolution and experiment time.
- Data Processing and Analysis:

- Apply a squared sine-bell window function in both dimensions before Fourier transformation to improve the appearance of the spectrum.
- Phase the spectrum carefully. NOESY spectra are phase-sensitive, and for small molecules, the diagonal peaks and cross-peaks will have opposite phases.[13]
- Analyze the cross-peaks. A cross-peak at the intersection of the chemical shifts of two protons ( $H_a$  and  $H_b$ ) indicates that these two protons are close in space.

## Visualizing the Decisive NOE Correlations

The following diagrams illustrate the key NOE correlations that would be expected for our hypothetical regioisomers, allowing for their unambiguous differentiation.

### Regioisomer A: Key NOE Correlations

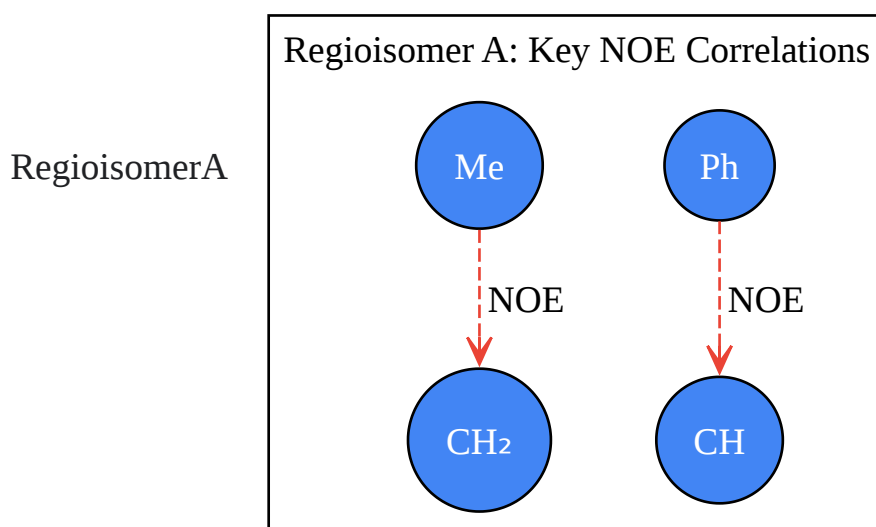

[Click to download full resolution via product page](#)

Figure 2. Expected key NOE correlations for Regioisomer A. A strong NOE is anticipated between the methyl and adjacent methylene protons, and between the phenyl and imine protons.

## Regioisomer B: Key NOE Correlations

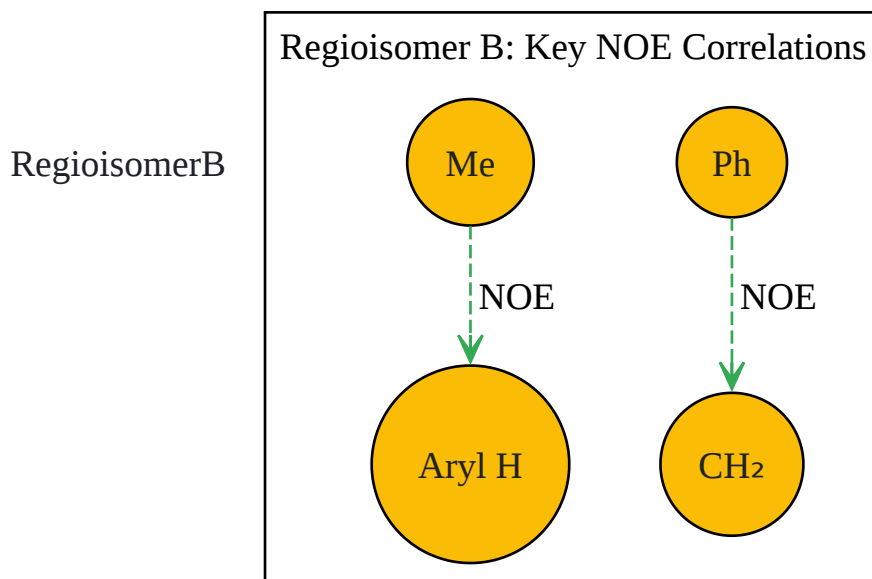

[Click to download full resolution via product page](#)

Figure 3. Expected key NOE correlations for Regioisomer B. A crucial NOE is predicted between the methyl protons and a proton on the fused aromatic ring, and between the phenyl and adjacent methylene protons.

## Comparative Data Summary

The following table summarizes the expected key NOE correlations that would allow for the definitive structural assignment of the two hypothetical diazepinone regioisomers.

Proton Interaction	Expected NOE in Regioisomer A	Expected NOE in Regioisomer B	Conclusion
Methyl Protons ↔ Methylene Protons	Strong	Absent	A strong indicator for Regioisomer A.
Phenyl Protons ↔ Imine Proton	Present	Absent	Confirms the proximity of the phenyl and imine groups in Regioisomer A.
Methyl Protons ↔ Aromatic Ring Proton	Absent	Present	A key indicator for Regioisomer B.
Phenyl Protons ↔ Methylene Protons	Absent	Present	Confirms the proximity of the phenyl and methylene groups in Regioisomer B.

## Conclusion: The Indispensable Role of NOESY in Regioisomer Validation

For researchers, scientists, and professionals in drug development, the correct assignment of molecular structure is non-negotiable. While a suite of analytical techniques is often employed, this guide has demonstrated the unique and decisive power of 2D NOESY in the specific and often challenging task of validating diazepam regioisomers. Unlike through-bond correlation experiments, NOESY's ability to probe through-space proximity provides irrefutable evidence of substituent placement. By understanding the principles of NOE and following a robust experimental and analytical workflow, researchers can confidently and accurately elucidate the structures of their target molecules, ensuring the integrity of their scientific findings and the progression of their research endeavors.

## References

- Oxford Instruments. (n.d.). Distinguishing Regioisomers in Pharmaceutical Products using Benchtop NMR Spectroscopy. Retrieved from [\[Link\]](#)<sup>[3]</sup><sup>[5]</sup>

- AZoM. (2024, September 2). Utilizing benchtop NMR spectroscopy to identify regioisomers in pharmaceutical compounds. Retrieved from [[Link](#)][4]
- Wikipedia. (2024, October 27). Nuclear Overhauser effect. Retrieved from [[Link](#)][6]
- International Journal of Pharmaceutical and Chemical Sciences. (2015). THEORETICAL STUDY OF 1, 4-DIAZEPINES SYNTHESIS: THE REACTION MECHANISM AND TAUTOMERISM IN GAS PHASE AND IN SOLUTION. Retrieved from [[Link](#)]
- University of Missouri. (n.d.). 2D-NOESY Spectra of Small Molecules - Hints And Tips. Retrieved from [[Link](#)][11]
- Bruker. (n.d.). Bruker TopSpin Training Guide for Basic 2D Experiments. Retrieved from [[Link](#)][10]
- YouTube. (2024, September 7). Nuclear Overhauser Effect - a double resonance NMR technique useful for structure elucidation. Retrieved from [[Link](#)][7]
- University of British Columbia. (n.d.). nmr training. Retrieved from [[Link](#)][12]
- Royal Society of Chemistry. (2018). Synthesis of 1,4-diazepinone derivatives via a domino aza-Michael/SN2 cyclization of 1-azadienes with  $\alpha$ -halogenoacetamides. Organic & Biomolecular Chemistry. Retrieved from [[Link](#)][2]
- ResearchGate. (2015). 1,4-Diazepines: A Review on Synthesis, Reactions and Biological Significance. Retrieved from [[Link](#)][1]
- JoVE. (2024, December 5). Video: Nuclear Overhauser Enhancement (NOE). Retrieved from [[Link](#)][8]
- Mestrelab Research. (2021, May 20). MNova: Guide to Processing Absolute-value and Phase- Sensitive 2D NMR Spectra. Retrieved from [[Link](#)][13]

### ***Need Custom Synthesis?***

*BenchChem offers custom synthesis for rare earth carbides and specific isotopic labeling.*

*Email: [info@benchchem.com](mailto:info@benchchem.com) or [Request Quote Online](#).*

## Sources

- [1. researchgate.net \[researchgate.net\]](#)
- [2. Synthesis of 1,4-diazepinone derivatives via a domino aza-Michael/SN2 cyclization of 1-azadienes with  \$\alpha\$ -halogenoacetamides - Organic & Biomolecular Chemistry \(RSC Publishing\) \[pubs.rsc.org\]](#)
- [3. nmr.oxinst.com \[nmr.oxinst.com\]](#)
- [4. news-medical.net \[news-medical.net\]](#)
- [5. Distinguishing Regioisomers in Pharmaceutical Products using Benchtop NMR Spectroscopy \[nmr.oxinst.com\]](#)
- [6. Nuclear Overhauser effect - Wikipedia \[en.wikipedia.org\]](#)
- [7. m.youtube.com \[m.youtube.com\]](#)
- [8. Video: Nuclear Overhauser Enhancement \(NOE\) \[jove.com\]](#)
- [9. JEOL USA blog | Basics of NOE/NOESY: Causes and Solutions When NO \[jeolusa.com\]](#)
- [10. pinmrf.purdue.edu \[pinmrf.purdue.edu\]](#)
- [11. 2210pc.chem.uic.edu \[2210pc.chem.uic.edu\]](#)
- [12. chem.ubc.ca \[chem.ubc.ca\]](#)
- [13. cdn.carleton.edu \[cdn.carleton.edu\]](#)
- [To cite this document: BenchChem. \[A Senior Application Scientist's Guide to Validating Diazepinone Regioisomers Using NOESY\]. BenchChem, \[2026\]. \[Online PDF\]. Available at: \[https://www.benchchem.com/product/b3344455/docs#a-senior-application-scientist-s-guide-to-validating-diazepinone-regioisomers-using-noesy\]](#)

---

### Disclaimer & Data Validity:

The information provided in this document is for Research Use Only (RUO) and is strictly not intended for diagnostic or therapeutic procedures. While BenchChem strives to provide accurate protocols, we make no warranties, express or implied, regarding the fitness of this product for every specific experimental setup.

**Technical Support:** The protocols provided are for reference purposes. Unsure if this reagent suits your experiment?

**Need Industrial/Bulk Grade?** [Request Custom Synthesis Quote](#)

## BenchChem

Our mission is to be the trusted global source of essential and advanced chemicals, empowering scientists and researchers to drive progress in science and industry.

### Contact

Address: 3281 E Guasti Rd  
Ontario, CA 91761, United States  
Phone: (601) 213-4426  
Email: [info@benchchem.com](mailto:info@benchchem.com)

[Contact our Ph.D. Support Team for a compatibility check](#)