

# Advanced Application Note: Ring-Closing Metathesis (RCM) Synthesis of Chiral Azepanes

**Author:** BenchChem Technical Support Team. **Date:** April 2026

## Compound of Interest

Compound Name: (4S)-N-Cbz-4-hydroxy-azepane

CAS No.: 1292324-55-0

Cat. No.: B3342159

[Get Quote](#)

## Abstract

The synthesis of chiral azepanes (seven-membered nitrogen heterocycles) presents a significant challenge in medicinal chemistry due to the high entropic barrier associated with medium-ring formation and the propensity for intermolecular oligomerization. This Application Note provides a validated, high-fidelity protocol for the construction of enantiopure azepane scaffolds using Ring-Closing Metathesis (RCM). We focus on overcoming the "medium-ring constraint" through conformational pre-organization via N-protecting group engineering and optimized Ruthenium-carbene catalysis.

## Introduction & Strategic Rationale

Azepane cores are privileged pharmacophores found in potent bioactive compounds, including the protein kinase C inhibitor (-)-Balanol [1] and various Orexin receptor antagonists [2]. Unlike 5- or 6-membered rings, 7-membered rings suffer from significant transannular strain and unfavorable entropy of activation (

).

## The Challenge: Entropy vs. Enthalpy

In RCM, the competition between Ring-Closing Metathesis (RCM) and Acyclic Diene Metathesis (ADMET) polymerization is concentration-dependent. For azepanes, the effective molarity (EM) is low.

- High Concentration (>0.1 M): Favors intermolecular oligomerization (ADMET).
- Low Concentration (<0.01 M): Favors intramolecular cyclization (RCM).

## The Solution: Conformational Control (The Rotamer Effect)

Success in azepane RCM relies on the Turnstile Effect. The nitrogen protecting group (PG) is not merely a shield; it is a structural lever.

- Carbamates (Boc, Cbz): Induce a cis-oid rotamer population around the N-C bond, bringing the two alkene chains into closer proximity, thereby lowering the entropic penalty of cyclization [3].
- Sulfonamides (Ts, Ns): Provide strong electron-withdrawing character, reducing the Lewis basicity of the nitrogen, which prevents chelation to the Ruthenium catalyst (catalyst poisoning).

## Mechanistic Pathway & Catalytic Cycle[1]

The reaction proceeds via the Chauvin mechanism.[1] For 7-membered rings, the formation of the metallacyclobutane intermediate is the rate-determining step.

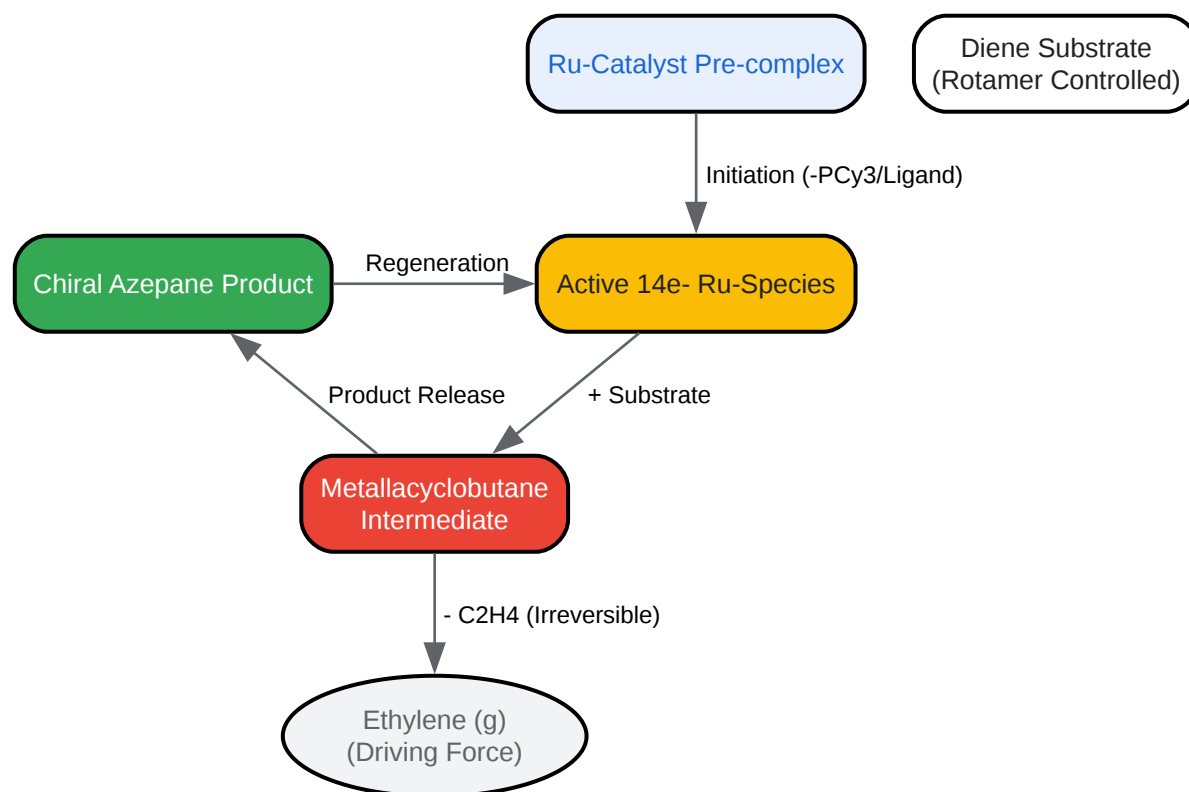

[Click to download full resolution via product page](#)

Figure 1: Simplified RCM catalytic cycle emphasizing the release of ethylene as the thermodynamic driving force.

## Critical Parameters and Optimization

### Catalyst Selection Table

Based on kinetic profiling of sterically hindered dienes.

Catalyst	Activity Profile	Tolerance	Recommendation
Grubbs I (G-I)	Moderate	Low (Sensitive to polar groups)	Use only for simple, unfunctionalized dienes.
Grubbs II (G-II)	High	High (Esters, Amides, Ketones)	Standard choice for azepane synthesis.
Hoveyda-Grubbs II	Very High	Excellent (Tolerates steric bulk)	Use for tetrasubstituted alkenes or difficult closures.
Schrock Mo-Cat	Extreme	Low (Air/Moisture sensitive)	Only if Ru-catalysts fail completely.

## Solvent & Concentration[2]

- Solvent: Dichloromethane (DCM) is standard. Toluene is used if higher temperatures (>40°C) are required to overcome the activation barrier.
- Concentration: 0.005 M to 0.01 M.
  - Note: Pseudo-high dilution (slow addition of substrate to catalyst solution) is preferred over static high dilution to minimize solvent waste while maintaining low instantaneous concentration.

## Validated Experimental Protocol

Target: Synthesis of N-Boc-2,3,4,7-tetrahydro-1H-azepine (Balanol Core Intermediate).

## Materials Preparation

- Substrate: N,N-diallyl-amino acid derivative (e.g., derived from L-serine or allylglycine for chirality). Ensure purity >98% by HPLC; trace amines poison the catalyst.
- Catalyst: Grubbs 2nd Generation (G-II).[1]

- Solvent: Anhydrous DCM (degassed).
- Scavenger: DMSO or SiliaMetS® (for Ru removal).

## Step-by-Step Workflow

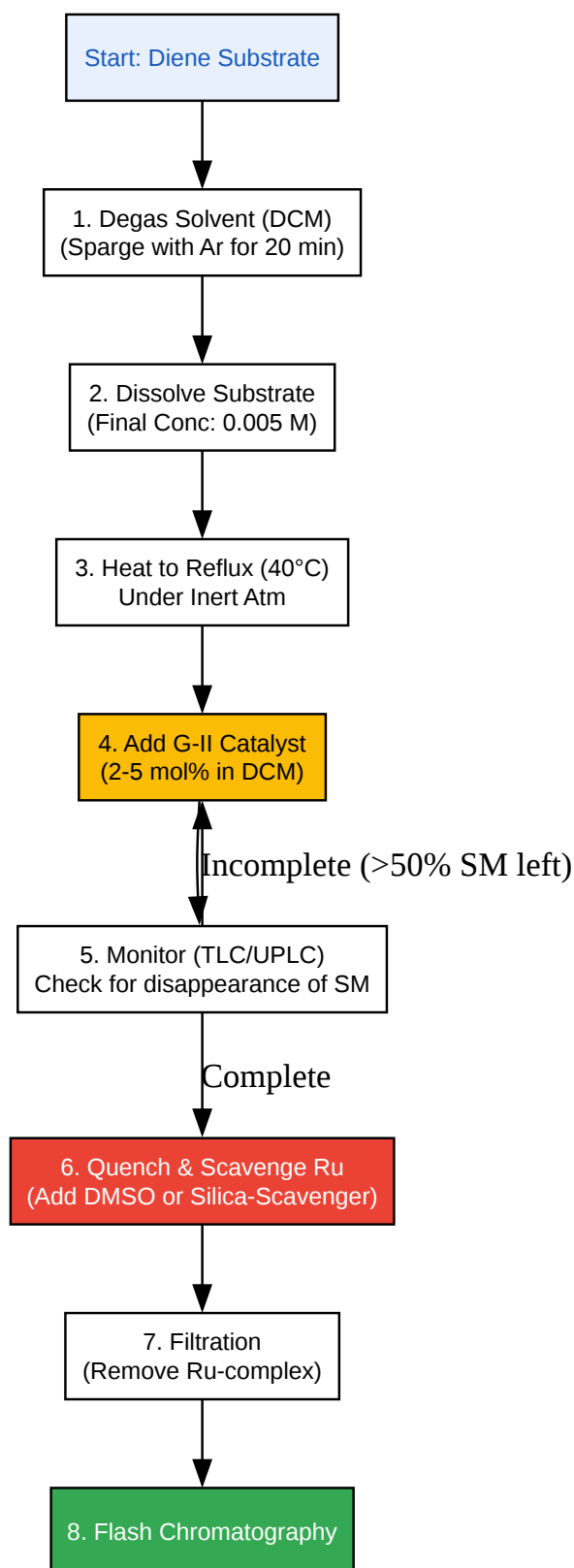

[Click to download full resolution via product page](#)

Figure 2: Operational workflow for the RCM of chiral azepanes.

## Detailed Execution

- **Degassing (Critical):** Place anhydrous DCM in a flame-dried round-bottom flask. Sparge with Argon or Nitrogen for 20 minutes. Oxygen is the primary cause of catalyst death.
- **Dissolution:** Dissolve the diene substrate in the degassed DCM to achieve a concentration of 0.005 M.
  - Example: 1.0 mmol substrate in 200 mL DCM.
- **Catalyst Addition:** Add Grubbs II catalyst (2–5 mol%) as a solid or dissolved in a minimal amount of degassed DCM.
- **Reaction:** Stir at reflux (40°C) under an inert atmosphere. The system must be open to a bubbler to allow ethylene gas to escape. Trapped ethylene drives the equilibrium back to the starting material.
- **Monitoring:** Check TLC every 2 hours. Reaction times vary from 2 to 24 hours.
- **Ruthenium Removal (The "Self-Validating" Step):**
  - **Method A (Standard):** Add DMSO (50 eq. relative to catalyst) and stir for 12 hours. The coordinated DMSO-Ru species does not bind to silica. Filter through a short pad of silica gel [4].
  - **Method B (High Purity):** Add SiliaMetS® Thiol scavenger (4 eq. relative to Ru), stir for 4 hours at 40°C, and filter.
- **Purification:** Concentrate the filtrate and purify via flash column chromatography (Hexanes/EtOAc).

## Troubleshooting & Optimization Matrix

Observation	Root Cause	Corrective Action
No Reaction	Catalyst poisoning (O <sub>2</sub> or Amines)	Ensure strict degassing. Verify N-protecting group stability. Use Ts-protection if amine is basic.
Oligomerization	Concentration too high	Dilute to 0.001 M. Use slow addition of substrate (syringe pump over 4h).
Incomplete Conversion	Catalyst decomposition	Add a second portion (2 mol%) of catalyst. Switch to Toluene and heat to 80°C.
Isomerization (Double bond migration)	Ruthenium hydride formation	Add 10 mol% 1,4-Benzoquinone or Ti(OiPr) <sub>4</sub> to the reaction mixture to suppress isomerization [5].

## References

- Fürstner, A., & Thiel, O. (2000).[2] Formal Total Synthesis of (-)-Balanol: Concise Approach to the Hexahydroazepine Segment Based on RCM. *The Journal of Organic Chemistry*, 65(6), 1738–1742. [Link](#)
- McAtee, J. J., et al. (2009). Conformational analysis of N,N-disubstituted-1,4-diazepane orexin receptor antagonists. *Bioorganic & Medicinal Chemistry Letters*, 19(11), 2997-3001.[3] [Link](#)
- Life Chemicals. (2020).[4] C-Substituted Azepanes for Novel Organic Synthesis and Drug Discovery Research. Application Note. [Link](#)
- Ahn, Y. M., Yang, K., & Georg, G. I. (2001).[1][5] A Convenient Method for the Efficient Removal of Ruthenium Byproducts Generated during Olefin Metathesis Reactions.[1][5][6][7] *Organic Letters*, 3(9), 1411–1413. [Link](#)

- Hong, S. H., & Grubbs, R. H. (2006). Efficient removal of ruthenium byproducts from olefin metathesis products by simple aqueous extraction. *Journal of the American Chemical Society*, 128(11), 3508–3509.[8] [Link](#)

#### Need Custom Synthesis?

BenchChem offers custom synthesis for rare earth carbides and specific isotopic labeling.

Email: [info@benchchem.com](mailto:info@benchchem.com) or [Request Quote Online](#).

## Sources

- [1. Ring Closing Metathesis \[organic-chemistry.org\]](#)
- [2. semanticscholar.org \[semanticscholar.org\]](#)
- [3. Conformational analysis of N,N-disubstituted-1,4-diazepane orexin receptor antagonists and implications for receptor binding - PubMed \[pubmed.ncbi.nlm.nih.gov\]](#)
- [4. lifechemicals.com \[lifechemicals.com\]](#)
- [5. A Convenient Method for the Efficient Removal of Ruthenium Byproducts Generated during Olefin Metathesis Reactions \[organic-chemistry.org\]](#)
- [6. A convenient method for the efficient removal of ruthenium byproducts generated during olefin metathesis reactions - PubMed \[pubmed.ncbi.nlm.nih.gov\]](#)
- [7. polymer.chem.cmu.edu \[polymer.chem.cmu.edu\]](#)
- [8. researchgate.net \[researchgate.net\]](#)
- To cite this document: BenchChem. [Advanced Application Note: Ring-Closing Metathesis (RCM) Synthesis of Chiral Azepanes]. BenchChem, [2026]. [Online PDF]. Available at: [\[https://www.benchchem.com/product/b3342159/docs#advanced-application-note-ring-closing-metathesis-rcm-synthesis-of-chiral-azepanes\]](https://www.benchchem.com/product/b3342159/docs#advanced-application-note-ring-closing-metathesis-rcm-synthesis-of-chiral-azepanes)

---

### Disclaimer & Data Validity:

The information provided in this document is for Research Use Only (RUO) and is strictly not intended for diagnostic or therapeutic procedures. While BenchChem strives to provide accurate protocols, we make no warranties, express or implied, regarding the fitness of this product for every specific experimental setup.

**Technical Support:** The protocols provided are for reference purposes. Unsure if this reagent suits your experiment?

**Need Industrial/Bulk Grade?** [Request Custom Synthesis Quote](#)

## BenchChem

Our mission is to be the trusted global source of essential and advanced chemicals, empowering scientists and researchers to drive progress in science and industry.

### Contact

Address: 3281 E Guasti Rd  
Ontario, CA 91761, United States  
Phone: (601) 213-4426  
Email: [info@benchchem.com](mailto:info@benchchem.com)

[Contact our Ph.D. Support Team for a compatibility check](#)