

Reproducibility of Diethyl Sulfate Ethylation Protocols in DMF: A Comparative Technical Guide

Author: BenchChem Technical Support Team. **Date:** April 2026

Compound of Interest

Compound Name:	<i>diethyl sulfate;N,N-dimethylformamide</i>
CAS No.:	1228182-35-1
Cat. No.:	B3339771

[Get Quote](#)

Executive Summary: The Case for Diethyl Sulfate in DMF

Diethyl sulfate (DES) remains a staple ethylating agent in industrial and semi-preparative organic synthesis due to its high atom economy and low cost compared to alkyl halides. When paired with

-Dimethylformamide (DMF), reaction rates for

- and

-ethylation are significantly accelerated due to the "naked anion" effect.[1]

However, reproducibility in this system is often plagued by three silent variables: solvent quality (water content), thermal instability of the reagent, and competitive solvent alkylation.[1] This

guide deconstructs these variables, offering a self-validating protocol that ensures consistent yields (>90%) while mitigating the severe toxicity risks associated with DES.

Critical Mechanism Analysis

The SN2 Landscape in DMF

The ethylation of phenols or amines by diethyl sulfate follows a classic SN2 mechanism. DMF, a polar aprotic solvent, effectively solvates the metal cation (e.g.,

from

), leaving the nucleophile (phenoxide or amine) poorly solvated and highly reactive.[1]

The "Hidden" Side Reaction: A frequent cause of yield variation is the alkylation of DMF itself. At elevated temperatures (>80°C), DES can ethylate the oxygen of the DMF amide bond, forming an

-ethylimidate salt. This consumes the alkylating agent and generates an impurity that complicates workup.

Mechanistic Pathway Diagram

The following diagram illustrates the primary product pathway versus the competitive hydrolysis and solvent alkylation pathways.

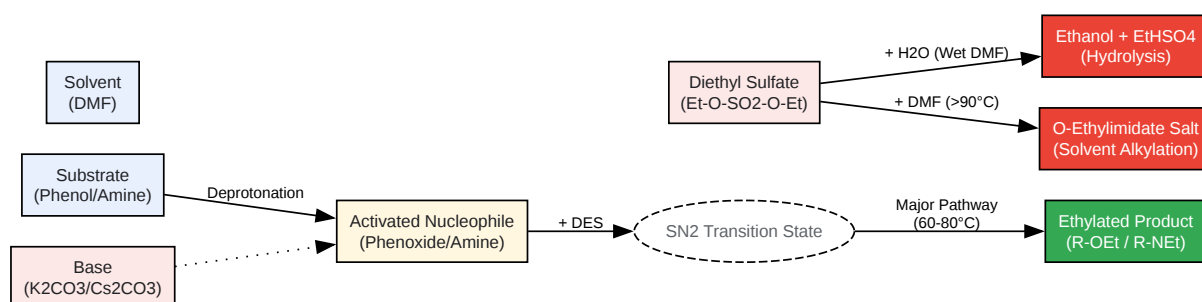

[Click to download full resolution via product page](#)

Figure 1: Reaction network showing the competitive pathways in DES ethylation. Note that high temperatures promote solvent alkylation, while moisture promotes hydrolysis.[1]

Comparative Performance Matrix

The following table contrasts DES with its primary alternatives, Ethyl Iodide (EtI) and Ethyl Tosylate (EtOTs), specifically within a DMF reaction environment.

Feature	Diethyl Sulfate (DES)	Ethyl Iodide (EtI)	Ethyl Tosylate (EtOTs)
Reactivity (k_rel)	High (Hard Electrophile)	Very High (Soft Electrophile)	Moderate
Typical Yield (Phenols)	85 – 95%	90 – 98%	75 – 85%
Atom Economy	Good (Transfers 1 Et group*)	Poor (High mass leaving group)	Poor (Large TsO group)
Reaction Temp.	60 – 80°C	25 – 60°C	80 – 110°C
Reproducibility Risk	Medium (Hydrolysis/Decomp)	Low (Stable, but volatile)	Low (Stable solid)
Toxicity Profile	Critical (Carcinogen, Mutagen)	High (Neurotoxin)	Low (Irritant)
Cost Efficiency	Excellent (Bulk commodity)	Low (Expensive)	Moderate

*Note: Under forcing conditions, both ethyl groups of DES can react, but typically only the first is utilized in mild synthesis to avoid harsh acidic byproducts.[1]

Self-Validating Experimental Protocol

Objective: Mono-O-ethylation of 4-Nitrophenol (Model Substrate) Scale: 10 mmol Solvent: Anhydrous DMF (Water < 0.05%)

Phase 1: System Setup & Safety

- Engineering Control: All operations must occur in a functioning fume hood. Double-gloving (Nitrile over Laminate) is mandatory due to DES skin permeability.
- Reagent Check: Verify DES quality. If the liquid is dark or cloudy, it has hydrolyzed/polymerized; discard and use a fresh bottle.

Phase 2: The Reaction (Step-by-Step)

- Charge: To a 50 mL round-bottom flask, add 4-Nitrophenol (1.39 g, 10 mmol) and Anhydrous (2.07 g, 15 mmol, 1.5 equiv).
- Solvation: Add Anhydrous DMF (10 mL). Stir at room temperature for 15 minutes.
 - Checkpoint 1: The solution should turn bright yellow/orange (formation of phenoxide anion). If the color is faint, water may be quenching the base.
- Addition: Add Diethyl Sulfate (1.45 mL, 11 mmol, 1.1 equiv) dropwise via syringe over 5 minutes.
- Reaction: Heat to 60°C (internal temperature). Stir for 2-4 hours.
 - Critical Control: Do not exceed 80°C. Higher temperatures accelerate the reaction of DES with DMF.
- Monitoring: Monitor by TLC (30% EtOAc/Hexane).
 - Checkpoint 2: Reaction is complete when the yellow phenoxide spot disappears and a less polar product spot appears.

Phase 3: Quench & Workup (The "LiCl Method")

Removing DMF is critical for reproducibility, as residual DMF can solubilize the product during extraction.

- Quench: Cool to room temperature. Add 2 mL of 10% aqueous ammonia (destroys excess DES). Stir for 15 mins.
- Dilution: Pour mixture into 50 mL of 5% LiCl solution.

- Why LiCl? Lithium chloride increases the ionic strength and breaks DMF-product H-bonds, forcing DMF into the aqueous phase.
- Extraction: Extract with Ethyl Acetate (mL).
- Wash: Wash combined organics with 5% LiCl (mL) followed by brine (mL).
- Dry & Concentrate: Dry over , filter, and concentrate.

Troubleshooting & Reproducibility Logic

Observation	Root Cause	Corrective Action
Low Yield (<50%)	Wet DMF caused DES hydrolysis.	Dry DMF over 4Å molecular sieves for 24h. Ensure is anhydrous.[2]
New impurity spot (TLC)	Reaction temp >90°C; DMF alkylation.	Keep temp <70°C. Switch to Acetone/reflux if temp control is difficult.
Product is an oil/gum	Residual DMF or DES.	Run a "polishing" wash with 5% LiCl. Check NMR for DMF peaks (δ 2.8, 2.9, 8.0).
Violent exotherm	Uncontrolled addition of DES.	DES addition must be dropwise.[3] The reaction is autocatalytic as heat is released.

References

- IARC Monographs on the Evaluation of Carcinogenic Risks to Humans. (1999). Diethyl Sulfate.[3][4][5] Vol 71. World Health Organization.[6] [[Link](#)]
- Kuhn, R., & Trischmann, H. (1963).[1] Permethylation of sugars and glycosides. *Chemische Berichte*, 96(1), 284-287.[1] (Foundational text on amide solvent alkylation side reactions). [[Link](#)]
- Vogel, A. I. (1989). *Vogel's Textbook of Practical Organic Chemistry* (5th ed.). Longman Scientific & Technical. (Standard protocols for alkyl sulfate handling). [[Link](#)]
- Reichardt, C., & Welton, T. (2010).[1] *Solvents and Solvent Effects in Organic Chemistry*. Wiley-VCH. (Mechanistic insight into DMF "naked anion" effect). [[Link](#)]
- National Center for Biotechnology Information. (2024). PubChem Compound Summary for CID 6163, Diethyl sulfate.[1] [[Link](#)]

Need Custom Synthesis?

BenchChem offers custom synthesis for rare earth carbides and specific isotopic labeling.

Email: info@benchchem.com or [Request Quote Online](#).

Sources

- 1. atamankimya.com [atamankimya.com]
- 2. pdf.benchchem.com [pdf.benchchem.com]
- 3. sciencemadness.org [sciencemadness.org]
- 4. Diethyl sulfate - Wikipedia [en.wikipedia.org]
- 5. Diethyl sulfate - Re-evaluation of Some Organic Chemicals, Hydrazine and Hydrogen Peroxide - NCBI Bookshelf [ncbi.nlm.nih.gov]
- 6. DIMETHYL SULFATE: REVIEW OF TOXICITY [nnk.gov.hu]
- To cite this document: BenchChem. [Reproducibility of Diethyl Sulfate Ethylation Protocols in DMF: A Comparative Technical Guide]. BenchChem, [2026]. [Online PDF]. Available at: [<https://www.benchchem.com/product/b3339771/docs#reproducibility-of-diethyl-sulfate-ethylation-protocols-in-dmf-a-comparative-technical-guide>]

Disclaimer & Data Validity:

The information provided in this document is for Research Use Only (RUO) and is strictly not intended for diagnostic or therapeutic procedures. While BenchChem strives to provide accurate protocols, we make no warranties, express or implied, regarding the fitness of this product for every specific experimental setup.

Technical Support: The protocols provided are for reference purposes. Unsure if this reagent suits your experiment?

Need Industrial/Bulk Grade? [Request Custom Synthesis Quote](#)

BenchChem

Our mission is to be the trusted global source of essential and advanced chemicals, empowering scientists and researchers to drive progress in science and industry.

Contact

Address: 3281 E Guasti Rd
Ontario, CA 91761, United States
Phone: (601) 213-4426
Email: info@benchchem.com

[Contact our Ph.D. Support Team for a compatibility check](#)