

# Technical Support Center: Minimizing Side Reactions During Sulfonamide Functionalization

**Author:** BenchChem Technical Support Team. **Date:** April 2026

## Compound of Interest

Compound Name: 4-Chloro-3-fluorobenzenesulfonamide  
CAS No.: 942035-78-1  
Cat. No.: B3338487

[Get Quote](#)

Welcome to the Technical Support Center for sulfonamide synthesis. This guide is designed for researchers, scientists, and drug development professionals to troubleshoot and optimize sulfonamide functionalization reactions. The sulfonamide moiety is a cornerstone in medicinal chemistry, but its synthesis and subsequent modification can be fraught with challenges, leading to side reactions that complicate purification and reduce yields.<sup>[1][2]</sup>

This document provides in-depth, experience-based solutions to common problems encountered in the lab, structured in a practical question-and-answer format.

## Frequently Asked Questions (FAQs)

### Q1: What are the most common side reactions during the initial sulfonylation of an amine?

The most prevalent side reactions are the over-sulfonylation of primary amines to form di-sulfonylated byproducts, and the hydrolysis of the sulfonyl chloride reagent.<sup>[3][4]</sup> Di-sulfonylation occurs when the initially formed mono-sulfonamide is deprotonated and reacts with a second equivalent of the sulfonyl chloride.<sup>[5]</sup> Hydrolysis to the corresponding sulfonic

acid happens when the highly reactive sulfonyl chloride is exposed to trace amounts of water in the solvent or on the glassware.[4][6]

## Q2: I'm planning an N-alkylation of a primary sulfonamide. What is the primary side reaction I should anticipate?

The most common issue is N,N-dialkylation.[7] After the desired mono-alkylation, the resulting secondary sulfonamide can be deprotonated again by the base, leading to a second alkylation event.[7] This is particularly problematic with reactive, unhindered alkylating agents like methyl iodide. Other potential side reactions include O-alkylation, where the sulfonamide anion acts as an ambident nucleophile, and elimination if you are using a secondary alkyl halide with a strong base.[7]

## Q3: Are there milder, more modern alternatives to the traditional sulfonyl chloride method for creating sulfonamides?

Yes, several innovative methods have been developed to circumvent the often harsh conditions required for sulfonyl chloride synthesis and use.[1][8] These include:

- Palladium-catalyzed cross-coupling reactions that can form sulfonamides from aryl boronic acids.[1][9]
- One-pot syntheses starting from thiols or disulfides via in-situ generation of the sulfonyl chloride.[10]
- Copper-catalyzed three-component reactions combining boronic acids, amines, and a sulfur dioxide surrogate like DABSO.[9]
- Using sulfonyl fluorides, which can offer different reactivity and selectivity profiles compared to sulfonyl chlorides.[11]

## Q4: My sulfonyl chloride reagent seems to be degrading, leading to low yields. Why is this happening?

Sulfonyl chlorides are highly electrophilic and susceptible to decomposition.<sup>[4]</sup> The primary cause is hydrolysis from trace moisture, converting it to the unreactive sulfonic acid.<sup>[4]</sup><sup>[12]</sup> Other causes include thermal decomposition at elevated temperatures and reaction with nucleophilic solvents.<sup>[4]</sup> It is crucial to use anhydrous solvents and reagents and perform the reaction under an inert atmosphere.<sup>[3]</sup><sup>[4]</sup>

## Troubleshooting Guide: Specific Issues & Solutions

### Issue 1: Formation of Di-Sulfonylated Byproduct in Primary Amine Reactions

**Symptom:** You observe a significant amount of a less polar, higher molecular weight byproduct by LC-MS or a new spot on your TLC plate during the sulfonylation of a primary amine. The yield of your desired mono-sulfonamide is low.

**Potential Cause:** The primary amine has reacted with two equivalents of the sulfonyl chloride, leading to a di-sulfonated product,  $R-N(SO_2R')_2$ .<sup>[5]</sup> This happens when the initially formed mono-sulfonamide is deprotonated by the base, creating a nucleophilic anion that attacks a second molecule of the sulfonyl chloride.<sup>[5]</sup>

**Proposed Solution & Protocol:**

The key is to control the reaction conditions to favor mono-sulfonylation.

1. Stoichiometry and Reagent Addition:

- **Control Stoichiometry:** Use only a slight excess (1.05-1.1 equivalents) of the sulfonyl chloride. A large excess strongly favors the side reaction.<sup>[5]</sup>
- **Slow, Cool Addition:** Add the sulfonyl chloride solution dropwise to the cooled (0 °C) solution of the amine and base.<sup>[5]</sup> This maintains a low instantaneous concentration of the electrophile, reducing the chance of a second reaction.

2. Choice of Base and Solvent:

- **Use a Non-Nucleophilic Base:** A bulky, non-nucleophilic base like triethylamine (TEA) is often sufficient.

- Pyridine as a Catalyst and Base: Pyridine is a classic choice as it can act as a nucleophilic catalyst to form a highly reactive sulfonylpyridinium salt, while also serving as the base.[13]

Detailed Experimental Protocol (Mono-sulfonylation of a Primary Amine):

- To a flame-dried, round-bottom flask under an inert atmosphere (N<sub>2</sub> or Ar), add the primary amine (1.0 eq.) and anhydrous dichloromethane (DCM).
- Cool the stirred solution to 0 °C using an ice bath.
- Add pyridine (2.0 eq.) to the solution.
- In a separate flask, dissolve the sulfonyl chloride (1.05 eq.) in a minimal amount of anhydrous DCM.
- Add the sulfonyl chloride solution dropwise to the amine solution over 30-60 minutes.
- Monitor the reaction by TLC or LC-MS. After the addition is complete, stir at 0 °C for 1 hour, then allow it to warm to room temperature and stir for an additional 2-16 hours until completion.[5]
- Workup: Quench the reaction with water or dilute acid. Extract the product with an organic solvent, wash with brine, dry over Na<sub>2</sub>SO<sub>4</sub>, and concentrate under reduced pressure.[3]
- Purification: Purify the crude product by column chromatography on silica gel.[3]

Mechanism Explained: By keeping the concentration of the sulfonyl chloride low through slow addition at a reduced temperature, the rate of the first reaction (desired) is favored over the second reaction (side reaction), which requires the deprotonation of the less basic mono-sulfonamide product before it can proceed.

Visualization of Competing Pathways:

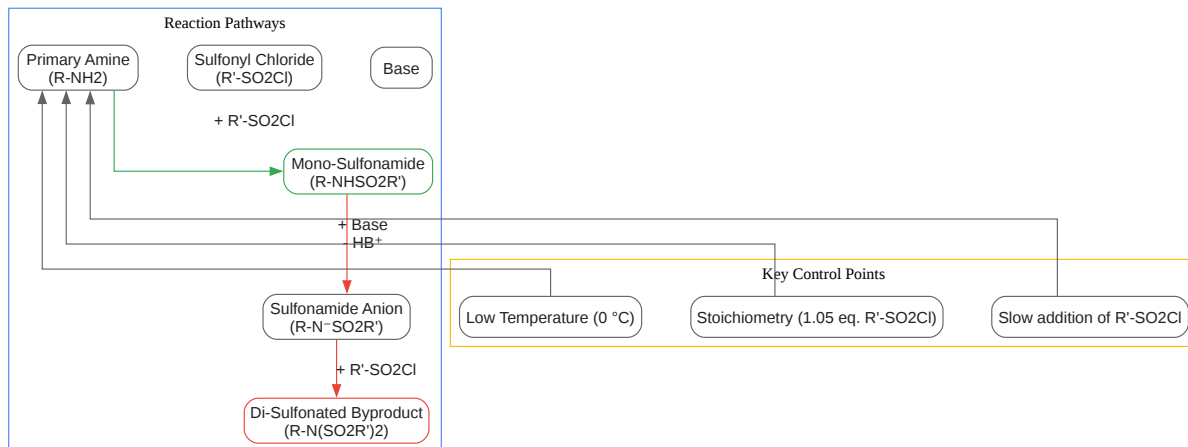

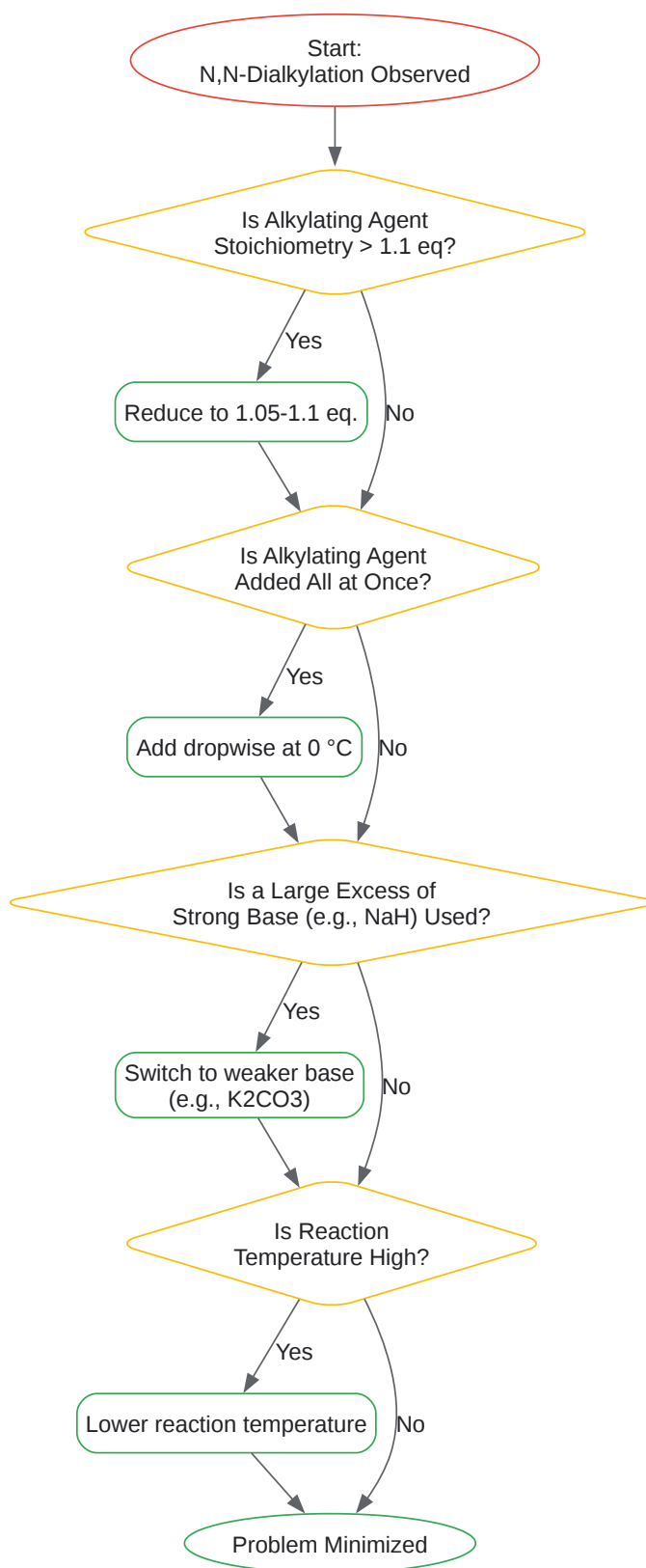

[Click to download full resolution via product page](#)

### Need Custom Synthesis?

BenchChem offers custom synthesis for rare earth carbides and specific isotopic labeling.

Email: [info@benchchem.com](mailto:info@benchchem.com) or [Request Quote Online](#).

## Sources

- 1. Synthesis of Aryl Sulfonamides via Palladium-Catalyzed Chlorosulfonylation of Arylboronic Acids - PMC [[pmc.ncbi.nlm.nih.gov](https://pubmed.ncbi.nlm.nih.gov/)]
- 2. Alkylation of Sulfonamides with Trichloroacetimidates Under Thermal Conditions - PMC [[pmc.ncbi.nlm.nih.gov](https://pubmed.ncbi.nlm.nih.gov/)]
- 3. [pdf.benchchem.com](https://pdf.benchchem.com) [[pdf.benchchem.com](https://pdf.benchchem.com)]
- 4. [pdf.benchchem.com](https://pdf.benchchem.com) [[pdf.benchchem.com](https://pdf.benchchem.com)]
- 5. [benchchem.com](https://benchchem.com) [[benchchem.com](https://benchchem.com)]
- 6. Kinetics and mechanism of hydrolysis of aromatic sulfonyl chlorides in aqueous sulfuric acid solutions (Journal Article) | OSTI.GOV [[osti.gov](https://www.osti.gov/)]
- 7. [pdf.benchchem.com](https://pdf.benchchem.com) [[pdf.benchchem.com](https://pdf.benchchem.com)]
- 8. [pdf.benchchem.com](https://pdf.benchchem.com) [[pdf.benchchem.com](https://pdf.benchchem.com)]
- 9. [pubs.acs.org](https://pubs.acs.org) [[pubs.acs.org](https://pubs.acs.org)]
- 10. Sustainable synthesis of sulfonamides via oxidative chlorination in alternative solvents: a general, mild, and eco-friendly strategy - RSC Sustainability (RSC Publishing) DOI:10.1039/D5SU00405E [[pubs.rsc.org](https://pubs.rsc.org/)]
- 11. [pubs.acs.org](https://pubs.acs.org) [[pubs.acs.org](https://pubs.acs.org)]
- 12. Organic Syntheses Procedure [[orgsyn.org](https://orgsyn.org/)]
- 13. [cbijournal.com](https://cbijournal.com) [[cbijournal.com](https://cbijournal.com)]
- To cite this document: BenchChem. [Technical Support Center: Minimizing Side Reactions During Sulfonamide Functionalization]. BenchChem, [2026]. [Online PDF]. Available at: [<https://www.benchchem.com/product/b3338487/docs#technical-support-center-minimizing-side-reactions-during-sulfonamide-functionalization>]

---

### Disclaimer & Data Validity:

The information provided in this document is for Research Use Only (RUO) and is strictly not intended for diagnostic or therapeutic procedures. While BenchChem strives to provide accurate protocols, we make no warranties, express or implied, regarding the fitness of this product for every specific experimental setup.

**Technical Support:** The protocols provided are for reference purposes. Unsure if this reagent suits your experiment?

**Need Industrial/Bulk Grade?** [Request Custom Synthesis Quote](#)

## BenchChem

Our mission is to be the trusted global source of essential and advanced chemicals, empowering scientists and researchers to drive progress in science and industry.

### Contact

Address: 3281 E Guasti Rd  
Ontario, CA 91761, United States  
Phone: (601) 213-4426  
Email: [info@benchchem.com](mailto:info@benchchem.com)

[Contact our Ph.D. Support Team for a compatibility check](#)