

# Mass Spectrometry Identification of Isocyanate Derivatives: A Comparative Technical Guide

**Author:** BenchChem Technical Support Team. **Date:** May 2026

## Compound of Interest

Compound Name: 4-Isocyanatobutanoic acid

CAS No.: 44855-96-1

Cat. No.: B3328345

[Get Quote](#)

## Executive Summary

Isocyanates (

) are potent electrophiles widely used in polyurethane manufacturing and present as reactive metabolites in drug development. Their high reactivity with nucleophiles (DNA, proteins) poses severe toxicity risks, including asthma and sensitization. Direct analysis of isocyanates is impossible due to their instability; therefore, derivatization is the mandatory first step in any analytical workflow.

This guide compares the three primary derivatization strategies used in industrial hygiene and pharmaceutical bioactivation studies: Dibutylamine (DBA), 1-(2-Pyridyl)piperazine (1,2-PP), and Glutathione (GSH). We analyze their performance in Liquid Chromatography-Tandem Mass Spectrometry (LC-MS/MS), focusing on ionization efficiency, fragmentation logic, and limit of detection (LOD).

## Part 1: The Challenge of Isocyanate Analysis

Isocyanates are "moving targets." In an LC-MS workflow, underivatized isocyanates will hydrolyze to amines or react with the mobile phase, rendering quantification impossible. The solution is to "trap" the isocyanate group using a nucleophilic reagent to form a stable urea or thiocarbamate adduct.

## The Core Dilemma: Stability vs. Sensitivity

- Industrial Standard (DBA): Prioritizes stability and UV detection but lacks sensitivity in Electrospray Ionization (ESI).
- MS-Optimized (1,2-PP/MP): Engineered for high ESI response but requires specific handling.
- Biological Trap (GSH): Mimics in vivo toxicity but produces complex spectra requiring neutral loss scanning.

## Part 2: Comparative Analysis of Derivatizing Agents Dibutylamine (DBA) – The Industrial Workhorse

DBA has long been the standard for OSHA and ISO methods (e.g., ISO 17734-1). It reacts rapidly to form stable urea derivatives.

- Mechanism: The secondary amine of DBA attacks the isocyanate carbon.
- MS Limitation: DBA derivatives are lipophilic but lack a highly basic site for protonation, leading to moderate ionization efficiency in ESI(+).
- Diagnostic Ion: The fragmentation is dominated by the cleavage of the urea bond, yielding the protonated reagent ion [DBA+H]<sup>+</sup> at m/z 130.

## 1-(2-Pyridyl)piperazine (1,2-PP) – The ESI-MS Specialist

1,2-PP (and its analog 1-(2-methoxyphenyl)piperazine, 1,2-MP) addresses the sensitivity gap.

- Mechanism: The secondary amine nitrogen of the piperazine ring reacts with the isocyanate.
- MS Advantage: The pyridyl nitrogen (or the tertiary piperazine nitrogen) has high proton affinity. This "pre-charged" nature boosts ESI signal intensity by 10–50x compared to DBA.

- Diagnostic Ion: Fragmentation yields the characteristic  $[1,2\text{-PP+H}]^+$  ion at  $m/z$  164.

## Glutathione (GSH) – The Bio-Activation Trap

Used primarily in drug metabolism (DMPK) to screen for reactive metabolites.

- Mechanism: The sulfhydryl (-SH) group of GSH attacks the isocyanate to form a thiocarbamate.
- MS Strategy: Unlike the urea derivatives, GSH adducts are identified via Neutral Loss Scanning (NLS).
- Diagnostic Feature: A consistent neutral loss of 129 Da (pyroglutamic acid moiety) upon collision-induced dissociation (CID).

## Comparative Performance Matrix

Feature	Dibutylamine (DBA)	1-(2-Pyridyl)piperazine (1,2-PP)	Glutathione (GSH)
Primary Application	Air Monitoring / Ind. Hygiene	Trace Analysis / Environmental	Drug Metabolism / Toxicology
Reaction Product	Urea	Urea	Thiocarbamate
ESI(+) Sensitivity	Moderate	High (Superior)	Moderate to High
MS/MS Mode	Product Ion Scan	Product Ion Scan	Neutral Loss Scan
Diagnostic Marker	Product Ion: $m/z$ 130	Product Ion: $m/z$ 164	Neutral Loss: 129 Da
Chromatography	High retention (Lipophilic)	Moderate retention	Low retention (Polar)
Limit of Detection	~1–5 nM	~0.05–0.1 nM	N/A (Qualitative)

## Part 3: Deep Dive – Fragmentation Logic & Causality

Understanding why these molecules fragment is crucial for method development.

## The "Reporter Tag" Concept

For DBA and 1,2-PP, the derivatizing agent acts as a "reporter tag." The urea bond formed is often the weakest link or the site of charge-directed cleavage.

- Pathway: Precursor  $[M+H]^+$

Cleavage of N-C(=O) bond

$[Reagent+H]^+$ .

- Causality: In 1,2-PP, the pyridine ring stabilizes the positive charge, making the formation of the m/z 164 ion thermodynamically favorable. This allows for highly selective Multiple Reaction Monitoring (MRM) transitions (Precursor 164).

## The GSH "Pyroglutamate" Loss

GSH conjugates undergo a specific intramolecular rearrangement.

- Pathway: The

-glutamyl moiety cyclizes to form pyroglutamic acid (129 Da), which is lost as a neutral molecule.

- Self-Validation: If a peak appears in a Neutral Loss 129 scan and disappears when incubated with N-acetylcysteine (an alternative trap), the hit is validated as a reactive electrophile.

## Visualization: Fragmentation Pathways[1]

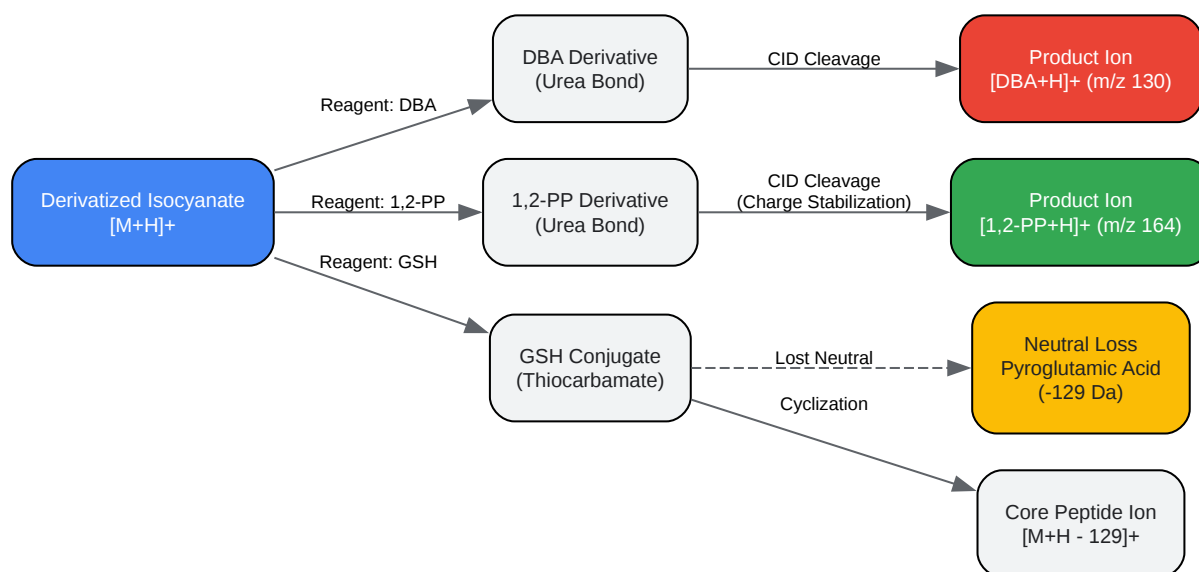

[Click to download full resolution via product page](#)

Figure 1: Comparative fragmentation logic. DBA and 1,2-PP yield specific product ions, while GSH conjugates are identified by a characteristic neutral loss.

## Part 4: Experimental Protocols

### Protocol A: High-Sensitivity Quantitation using 1,2-PP

Best for: Environmental analysis, trace impurity quantification.

- Reagent Preparation: Prepare a 1 mg/mL solution of 1-(2-pyridyl)piperazine in Acetonitrile (ACN).
- Sample Derivatization:
  - Add 100  $\mu$ L of sample (isocyanate in non-protic solvent like DMSO or DCM) to a vial.
  - Add 200  $\mu$ L of reagent solution.

L of 1,2-PP solution (ensure >10-fold molar excess).

- Critical Step: Incubate at 60°C for 20 minutes. Why? Sterically hindered isocyanates require heat to drive the reaction to completion.
- Evaporate solvent under  
  
and reconstitute in Mobile Phase A (Water + 0.1% Formic Acid).
- LC-MS/MS Conditions:
  - Column: C18 Reverse Phase (e.g., 2.1 x 50 mm, 1.7 m).
  - Mobile Phase: Gradient of Water/ACN with 0.1% Formic Acid.
  - MS Mode: Positive ESI, MRM.
  - Transitions: Monitor  $[M+H]^+$   
  
164.1.

## Protocol B: Reactive Metabolite Screening using GSH

Best for: Drug safety assessment (DMPK).

- Incubation:
  - Mix Test Compound (10 M) + Human Liver Microsomes (1 mg/mL) + NADPH + GSH (5 mM).
  - Buffer: Potassium Phosphate (pH 7.4).
  - Incubate at 37°C for 60 mins.
- Quenching: Add equal volume of ice-cold ACN to precipitate proteins. Centrifuge at 10,000g.
- Data Acquisition:

- Inject supernatant onto LC-MS.
- Scan Mode: Perform a Neutral Loss Scan (NLS) of 129 Da.
- Trigger: Set data-dependent MS/MS acquisition on peaks exhibiting the loss.

## Part 5: Analytical Workflow Visualization

This diagram illustrates the decision matrix for selecting the correct workflow based on the sample type.

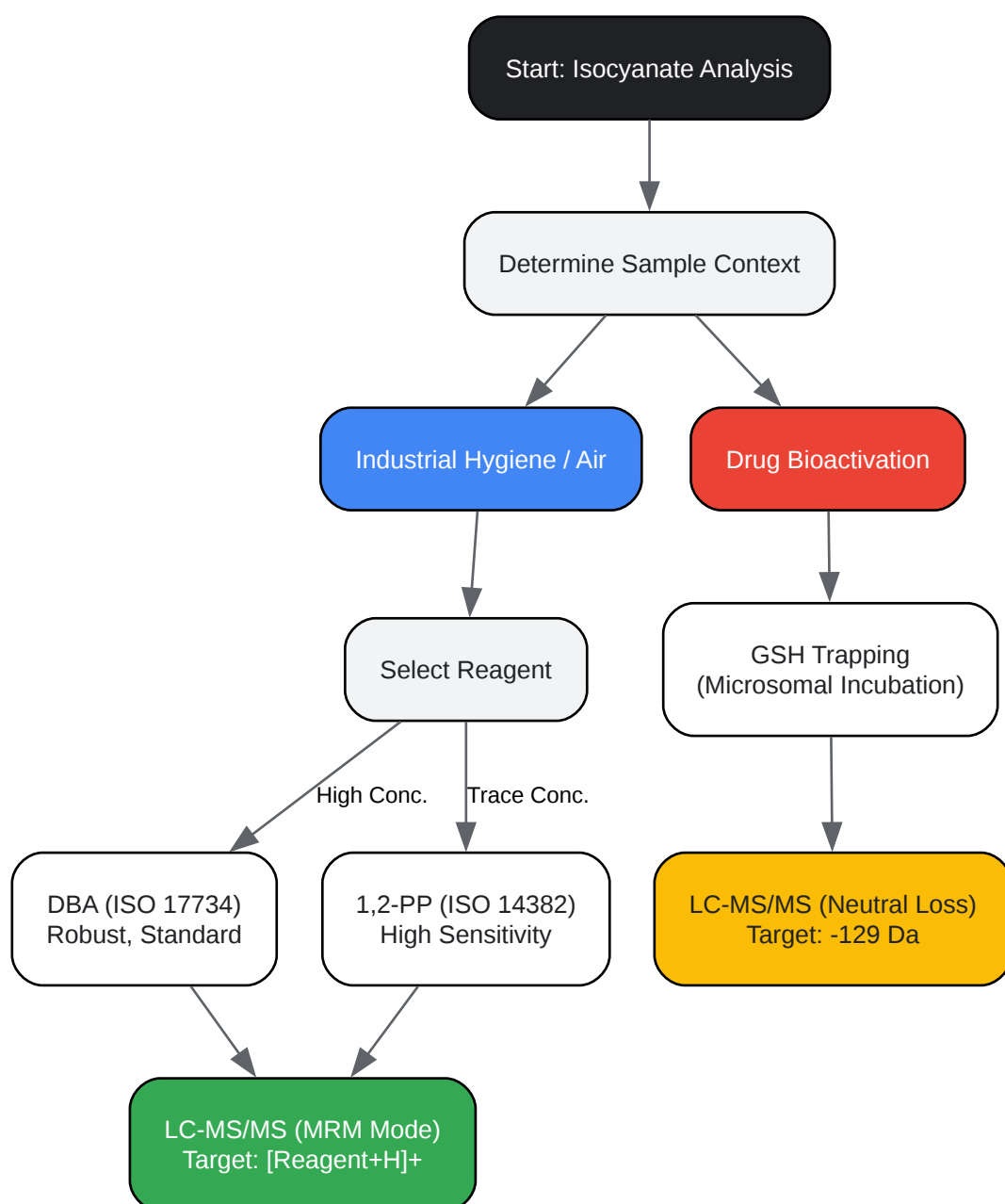

[Click to download full resolution via product page](#)

Figure 2: Decision tree for selecting derivatization reagents and MS scan modes.

## References

- ISO 17734-1:2013. Determination of organonitrogen compounds in air using liquid chromatography and mass spectrometry — Part 1: Isocyanates using dibutylamine derivatives. International Organization for Standardization.[1] [Link](#)
- ISO 14382:2012. Workplace atmospheres — Determination of toluene diisocyanate vapours using 1-(2-pyridyl)piperazine-coated glass fibre filters and analysis by high performance liquid chromatography with ultraviolet and fluorescence detectors.[1] International Organization for Standardization.[1] [Link](#)
- Karlsson, D., et al. (2005). Determination of isocyanates in air using 1-(2-methoxyphenyl)piperazine-impregnated filters: Long-term sampling performance and field comparison. Journal of Environmental Monitoring. [Link](#)
- Dieckhaus, H., et al. (2005). Novel glutathione conjugates of phenyl isocyanate identified by ultra-performance liquid chromatography/electrospray ionization mass spectrometry. Chemical Research in Toxicology. [Link](#)
- Thermo Fisher Scientific. Detection and identification of isotope-labeled glutathione trapped reactive drug metabolites. Application Note. [Link](#)

### Need Custom Synthesis?

BenchChem offers custom synthesis for rare earth carbides and specific isotopic labeling.

Email: [info@benchchem.com](mailto:info@benchchem.com) or [Request Quote Online](#).

## Sources

- 1. Total Reactive Isocyanate Group (TRIG) Measurement: A Commentary - PMC [[pmc.ncbi.nlm.nih.gov](https://pubmed.ncbi.nlm.nih.gov)]

- To cite this document: BenchChem. [Mass Spectrometry Identification of Isocyanate Derivatives: A Comparative Technical Guide]. BenchChem, [2026]. [Online PDF]. Available at: [<https://www.benchchem.com/product/b3328345/docs#mass-spectrometry-identification-of-isocyanate-derivatives-a-comparative-technical-guide>]

---

### Disclaimer & Data Validity:

The information provided in this document is for Research Use Only (RUO) and is strictly not intended for diagnostic or therapeutic procedures. While BenchChem strives to provide accurate protocols, we make no warranties, express or implied, regarding the fitness of this product for every specific experimental setup.

**Technical Support:** The protocols provided are for reference purposes. Unsure if this reagent suits your experiment?

**Need Industrial/Bulk Grade?** [Request Custom Synthesis Quote](#)

## BenchChem

Our mission is to be the trusted global source of essential and advanced chemicals, empowering scientists and researchers to drive progress in science and industry.

### Contact

Address: 3281 E Guasti Rd  
Ontario, CA 91761, United States  
Phone: (601) 213-4426  
Email: [info@benchchem.com](mailto:info@benchchem.com)

[Contact our Ph.D. Support Team for a compatibility check](#)