

A Comparative Guide to Validating Synthetic Pathways for Chemical Library Synthesis

Author: BenchChem Technical Support Team. **Date:** May 2026

Compound of Interest

Compound Name: 4-Methoxy-2(1H)-pyridinone

CAS No.: 95907-06-5

Cat. No.: B3317337

[Get Quote](#)

Introduction: The Blueprint for Discovery

In the landscape of modern drug discovery, the synthesis of large, diverse chemical libraries is the foundational step for identifying novel biological hits through high-throughput screening (HTS).^{[1][2]} The success of any screening campaign is inextricably linked to the quality, diversity, and reliability of the compound library. Therefore, the synthetic pathway used to generate this library is not merely a series of reactions; it is the blueprint for discovery. A rigorously validated pathway ensures that the intended molecules are produced in high purity and yield, and that the synthesis is robust enough to accommodate a wide array of building blocks.

This guide provides an in-depth comparison of methodologies for validating a synthetic pathway for library production. We will move beyond theoretical steps to explain the causality behind experimental choices, offering a framework that is both scientifically sound and field-proven. We will dissect a primary synthetic pathway, compare it against viable alternatives, and provide the quantitative data and detailed protocols necessary for you to make informed decisions in your own research.

The Core Objective: A Self-Validating System

The goal of pathway validation is to establish a self-validating system. This means that for any given set of starting materials, the chosen synthetic route should predictably yield the desired product with acceptable purity and quantity, minimizing the need for extensive purification and characterization of every library member. This is crucial for accelerating the discovery process and ensuring the integrity of screening data.^[3]

Overall Validation Workflow

The validation process can be visualized as a funnel, starting with broad scoping and progressively narrowing down to a highly optimized, production-ready protocol.

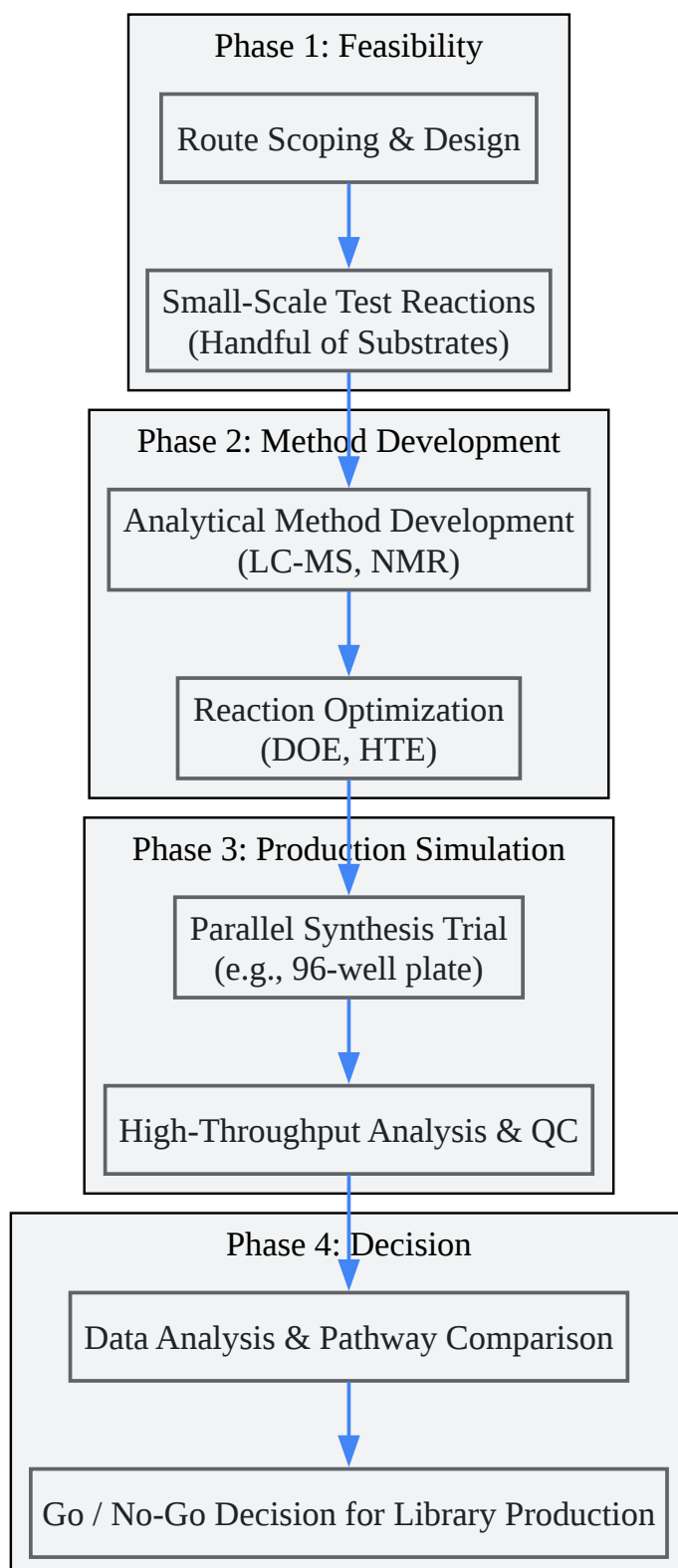

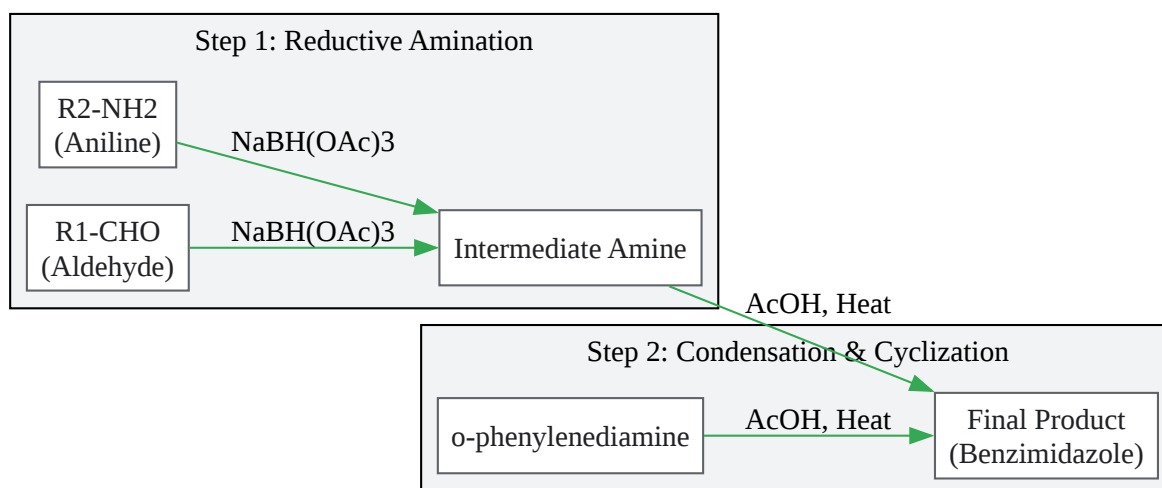

[Click to download full resolution via product page](#)

Caption: Primary Synthetic Pathway (P1) for Benzimidazole Library.

Key Validation Metrics

Before initiating experiments, we must define the key performance indicators (KPIs) that will determine the pathway's suitability.

- **Yield:** The amount of desired product obtained. For library synthesis, consistency across different substrates is more important than achieving a perfect 99% yield for a single reaction.
- **Purity:** The percentage of the final sample that is the desired compound. The goal is to achieve a purity level (e.g., >85-90%) that is sufficient for HTS without requiring individual purification. [4][5]3. **Scope & Diversity:** The range of different building blocks (R1, R2, etc.) that the reaction tolerates. A good pathway is robust to electronic and steric variations in the starting materials. [6][7]4. **Efficiency & Scalability:** This includes reaction time, ease of workup, and the potential for automation. A scalable process should not require complex manipulations like column chromatography for each well. [1]5. **Cost & Atom Economy:** The cost of starting materials, reagents, and solvents, as well as the efficiency with which atoms from the reactants are incorporated into the final product. [8][9]

Experimental Validation of the Primary Pathway (P1)

Protocol 1: Small-Scale Feasibility Testing

Objective: To confirm the viability of the two-step synthesis with a representative set of building blocks.

Methodology:

- **Select Substrates:** Choose 4 aldehydes (R1-CHO) and 4 anilines (R2-NH₂) with varying electronic properties (electron-donating and electron-withdrawing groups) and steric bulk.
- **Step 1 (Reductive Amination):** In 16 separate vials, dissolve an aldehyde (1.0 eq) and an aniline (1.0 eq) in Dichloromethane (DCM). Add sodium triacetoxyborohydride (1.5 eq) and stir at room temperature for 4 hours.
- **Workup & Analysis:** Quench the reaction with aqueous NaHCO₃. Extract the organic layer, dry with Na₂SO₄, and concentrate. Analyze the crude product by LC-MS and ¹H NMR to confirm the formation of the intermediate secondary amine.
 - **Causality:** Using a representative but diverse set of substrates at this stage quickly identifies potential failure points. For instance, highly electron-deficient anilines may react sluggishly, indicating a need for longer reaction times or heating.
- **Step 2 (Cyclization):** Take the crude intermediate from each successful Step 1 reaction and dissolve it in acetic acid with o-phenylenediamine (1.1 eq). Heat the mixture at 80°C for 6 hours.
- **Final Analysis:** Cool the reaction, dilute with water, and neutralize with NaOH. Extract with ethyl acetate. Analyze the crude final product by LC-MS to determine purity and confirm the identity of the benzimidazole product.

Protocol 2: Parallel Synthesis Validation in 96-Well Plate

Objective: To simulate the library production environment and assess the robustness and reproducibility of the pathway in a high-throughput format. [1] Methodology:

- Plate Mapping: Design a 96-well plate map. Use 8 different aldehydes and 12 different anilines to generate 96 unique products. Include empty wells for controls.
- Reagent Preparation: Prepare stock solutions of all starting materials and reagents.
- Automated Dispensing (Step 1): Using a liquid handler, dispense the appropriate aldehyde and aniline stock solutions into each well of a 1 mL 96-well reaction block. Add the reducing agent solution.
- Incubation: Seal the plate and place it on a shaker at room temperature for 4 hours.
- Reagent Dispensing (Step 2): Unseal the plate and add the o-phenylenediamine and acetic acid solutions to each well.
- Heating & Incubation: Reseal the plate with a heat-resistant seal and place it in a heated shaker block at 80°C for 6 hours.
- High-Throughput Workup: Perform a liquid-liquid extraction directly in the plate or use a solid-phase extraction (SPE) protocol to remove excess reagents and byproducts.
- Analysis: Dilute a small aliquot from each well into a new 96-well analysis plate. Perform rapid LC-MS analysis on all 96 samples to determine the purity and yield distribution across the library.
 - Trustworthiness: This protocol is self-validating. The distribution of yields and purities across the 96-well plate provides immediate feedback on the pathway's generalizability. A high success rate (>80% of wells showing >85% purity) validates the pathway for full-scale library production. [3]

Comparison with Alternative Synthetic Pathways

To ensure the chosen pathway is optimal, it must be compared against other viable routes.

Alternative Pathway 2 (P2): Solid-Phase Synthesis

Here, the o-phenylenediamine is attached to a solid support (resin). This approach simplifies purification, as excess reagents and byproducts are simply washed away. [10]

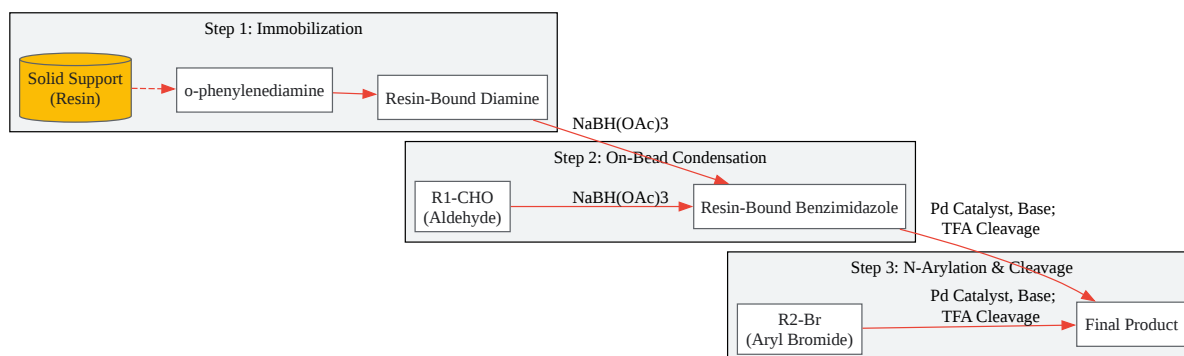

[Click to download full resolution via product page](#)

Caption: Alternative Solid-Phase Pathway (P2).

Alternative Pathway 3 (P3): One-Pot Condensation

This approach aims for maximum efficiency by combining all three components in a single reaction vessel, catalyzed by a Lewis acid.

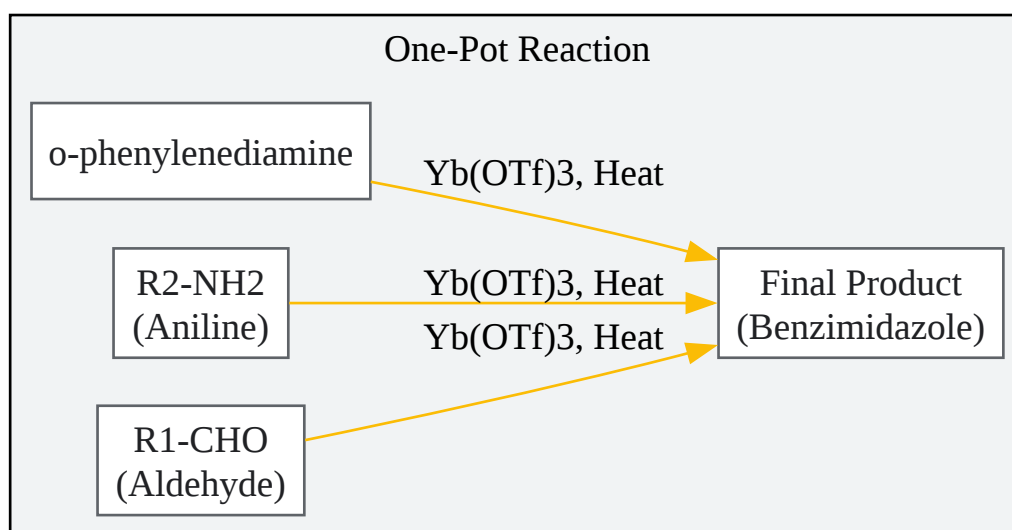

[Click to download full resolution via product page](#)

Caption: Alternative One-Pot Pathway (P3).

Quantitative Performance Comparison

After performing validation experiments on all three pathways with the same set of diverse starting materials, the results are summarized below.

Metric	Primary Pathway (P1)	Alternative Pathway (P2)	Alternative Pathway (P3)	Rationale & Justification
Average Yield	65%	55% (after cleavage)	45%	P1 provides a reliable yield. P2 suffers from incomplete reactions on solid support. P3 has lower yields due to competing side reactions in the one-pot format.
Average Purity (Crude)	88%	92%	70%	P2's main advantage is high purity due to the wash-away workup. [10]P1 is very good, while P3 requires significant purification.
Reaction Scope	Very Good	Good	Moderate	P1 is tolerant of most functional groups. P2 is limited by conditions for attachment/cleavage. P3 is sensitive to sterically hindered substrates.
Time (per 96 wells)	12 hours	24 hours	8 hours	P3 is the fastest, but this is offset

by poor purity. P2 is slowest due to resin washing and cleavage steps.

Automation Potential

High

High

Moderate

Both P1 and P2 are well-suited for liquid handlers and automated platforms. P3 can be automated but workup is more complex.

Cost per Compound

Low

High

Medium

P1 uses inexpensive bulk reagents. P2 requires expensive resin and palladium catalysts. P3 has moderate costs but may increase with purification needs.

Conclusion and Recommendation

Based on the comparative validation data, the Primary Pathway (P1) emerges as the most balanced and robust choice for large-scale library synthesis.

- P1 (Solution-Phase) offers the best compromise between yield, purity, reaction scope, and cost. Its high potential for automation and the straightforward nature of the reactions make it ideal for generating a large and diverse library with consistent quality.

- P2 (Solid-Phase) is a strong contender, particularly when exceptionally high purity is required directly from synthesis, but at a higher cost and with a longer timeline. It would be the preferred method for a smaller, more focused library where purity is paramount.
- P3 (One-Pot), while efficient in terms of time, fails on the critical metrics of purity and yield. The extensive purification required for each compound would negate the time saved in the reaction step, making it unsuitable for library production.

This guide demonstrates a systematic, data-driven approach to synthetic pathway validation. By defining clear metrics, performing simulated production runs, and objectively comparing alternatives, researchers can select and optimize a synthetic route that is not only chemically sound but also strategically aligned with the goals of their drug discovery program.

References

- Parallel Synthesis & High-Throughput Experimentation. SpiroChem. [\[Link\]](#)
- NEW ADVANCES IN DIVERSITY- ORIENTED SYNTHESIS. David Spring's group, University of Cambridge. [\[Link\]](#)
- High-throughput synthesis of azide libraries suitable for direct “click” chemistry and in situ screening. Organic & Biomolecular Chemistry, RSC Publishing. [\[Link\]](#)
- Evaluating Scalable Supervised Learning for Synthesize-on-Demand Chemical Libraries. PMC. [\[Link\]](#)
- Constructing de novo biosynthetic pathways for chemical synthesis inside living cells. PMC. [\[Link\]](#)
- Discovery of hybrid chemical synthesis pathways with DORAnet. RSC Publishing. [\[Link\]](#)
- Computational Chemical Synthesis Analysis and Pathway Design. Frontiers in Chemistry. [\[Link\]](#)
- Diversity-Oriented Synthetic Strategies Applied to Cancer Chemical Biology and Drug Discovery. PMC. [\[Link\]](#)

- High-Throughput Screening of Natural Product and Synthetic Molecule Libraries for Antibacterial Drug Discovery. MDPI. [\[Link\]](#)
- Purity Assessment of Drug Discovery Compound Libraries Using an Agilent Single Quadrupole LC/MS System. Agilent. [\[Link\]](#)
- Diversity-oriented synthesis of macrocyclic peptidomimetics. PNAS. [\[Link\]](#)
- Next generation diversity-oriented synthesis: a paradigm shift from chemical diversity to biological diversity. Organic & Biomolecular Chemistry, RSC Publishing. [\[Link\]](#)
- Experimental validation of the predicted synthesis route for an FDA-approved drug. ResearchGate. [\[Link\]](#)
- A simple similarity metric for comparing synthetic routes. ResearchGate. [\[Link\]](#)
- Synthetic Strategies in Combinatorial Chemistry. ResearchGate. [\[Link\]](#)
- Using Data Analysis To Evaluate and Compare Chemical Syntheses. Organic Process Research & Development, ACS Publications. [\[Link\]](#)
- Diversity-oriented synthesis; a challenge for synthetic chemists. SciSpace. [\[Link\]](#)
- Discovery of hybrid chemical synthesis pathways with DORAnet. RSC Publishing. [\[Link\]](#)
- Peptide Purity & Yield Optimizing in SPPS. Gyros Protein Technologies. [\[Link\]](#)
- Synthetic strategies in combinatorial chemistry. PubMed. [\[Link\]](#)
- Best Practices for Documenting Synthesis Steps and Managing Reagents. Sapio Sciences. [\[Link\]](#)
- The impact of synthetic biology on drug discovery. PMC. [\[Link\]](#)
- LinChemIn: SynGraph. A data model and a toolkit to analyze and compare synthetic routes. Journal of Cheminformatics. [\[Link\]](#)

- Combinatorial Chemistry with Solid Phase Synthesis: An Outline. CR Subscription Agency. [\[Link\]](#)
- What would be the quickest and simplest way to test the purity of a compound after synthesis? ResearchGate. [\[Link\]](#)
- Making Better Decisions During Synthetic Route Design: Leveraging Prediction to Achieve Greenness-by-Design. ChemRxiv. [\[Link\]](#)
- LinChemIn: SynGraph—a data model and a toolkit to analyze and compare synthetic routes. PMC. [\[Link\]](#)
- Computational toxicology methods in chemical library design and high-throughput screening hit validation. PMC. [\[Link\]](#)
- Recent Advances in Library Synthesis to Accelerate Medicinal Chemistry Research. YouTube. [\[Link\]](#)
- Determination of purity and yield. PubMed. [\[Link\]](#)
- Schedule optimization for chemical library synthesis. Digital Discovery, RSC Publishing. [\[Link\]](#)
- Retro-forward synthesis design and experimental validation of potent structural analogs of known drugs. RSC Publishing. [\[Link\]](#)
- Synthetic data from diffusion models improves drug discovery prediction. arXiv. [\[Link\]](#)
- Synthetic Biology Speeds Up Drug Target Discovery. Frontiers in Bioengineering and Biotechnology. [\[Link\]](#)
- CHAPTER 2: Parallel Synthesis and Library Design. The Royal Society of Chemistry. [\[Link\]](#)
- Drug target inference through pathway analysis of genomics data. PMC. [\[Link\]](#)
- Exploring Novel Synthetic Routes in Medicinal Chemistry. Hilaris Publisher. [\[Link\]](#)

Need Custom Synthesis?

BenchChem offers custom synthesis for rare earth carbides and specific isotopic labeling.

Email: info@benchchem.com or [Request Quote Online](#).

Sources

- [1. Parallel Synthesis & High-Throughput Experimentation | SpiroChem \[spirochem.com\]](#)
- [2. High-Throughput Screening of Natural Product and Synthetic Molecule Libraries for Antibacterial Drug Discovery \[mdpi.com\]](#)
- [3. youtube.com \[youtube.com\]](#)
- [4. agilent.com \[agilent.com\]](#)
- [5. gyrosproteintechnologies.com \[gyrosproteintechnologies.com\]](#)
- [6. www-spring.ch.cam.ac.uk \[www-spring.ch.cam.ac.uk\]](#)
- [7. Diversity-Oriented Synthetic Strategies Applied to Cancer Chemical Biology and Drug Discovery - PMC \[pmc.ncbi.nlm.nih.gov\]](#)
- [8. pubs.acs.org \[pubs.acs.org\]](#)
- [9. chemrxiv.org \[chemrxiv.org\]](#)
- [10. crsubscription.com \[crsubscription.com\]](#)
- To cite this document: BenchChem. [A Comparative Guide to Validating Synthetic Pathways for Chemical Library Synthesis]. BenchChem, [2026]. [Online PDF]. Available at: [\[https://www.benchchem.com/product/b3317337/docs#a-comparative-guide-to-validating-synthetic-pathways-for-chemical-library-synthesis\]](https://www.benchchem.com/product/b3317337/docs#a-comparative-guide-to-validating-synthetic-pathways-for-chemical-library-synthesis)

Disclaimer & Data Validity:

The information provided in this document is for Research Use Only (RUO) and is strictly not intended for diagnostic or therapeutic procedures. While BenchChem strives to provide accurate protocols, we make no warranties, express or implied, regarding the fitness of this product for every specific experimental setup.

Technical Support: The protocols provided are for reference purposes. Unsure if this reagent suits your experiment?

Need Industrial/Bulk Grade? [Request Custom Synthesis Quote](#)

BenchChem

Our mission is to be the trusted global source of essential and advanced chemicals, empowering scientists and researchers to drive progress in science and industry.

Contact

Address: 3281 E Guasti Rd
Ontario, CA 91761, United States
Phone: (601) 213-4426
Email: info@benchchem.com

[Contact our Ph.D. Support Team for a compatibility check](#)