

synthesis of biaryls using 5-Chloro-3-fluoro-2-iodotoluene intermediate

Author: BenchChem Technical Support Team. **Date:** April 2026

Compound of Interest

Compound Name: 5-Chloro-3-fluoro-2-iodotoluene

CAS No.: 939990-13-3

Cat. No.: B3308847

[Get Quote](#)

Application Note: Site-Selective Synthesis of Biaryls Utilizing **5-Chloro-3-fluoro-2-iodotoluene**

Executive Summary

Subject: Strategic utilization of **5-Chloro-3-fluoro-2-iodotoluene** (CAS: 83121-18-0 / Analogues) as a linchpin intermediate in the synthesis of polysubstituted biaryls. Core Challenge: The target molecule features a highly congested C-I bond flanked by ortho-methyl and ortho-fluorine substituents (the "ortho-ortho effect"), creating significant steric resistance to transmetallation during cross-coupling. Solution: This guide details optimized Suzuki-Miyaura and Negishi protocols utilizing sterically demanding phosphine ligands (Buchwald-type) to overcome the activation energy barrier while maintaining complete chemoselectivity over the C-Cl bond.

Structural Analysis & Mechanistic Rationale

The scaffold **5-Chloro-3-fluoro-2-iodotoluene** presents a unique reactivity profile defined by three distinct halogen/pseudo-halogen sites. Understanding the electronic and steric hierarchy is prerequisite to successful method design.

The Reactivity Hierarchy

The molecule contains three potential oxidative addition sites. Under Palladium (0) catalysis, the reactivity order is governed by Bond Dissociation Energy (BDE) and steric accessibility.

Site	Substituent	Approx. BDE (kcal/mol)	Steric Environment	Reactivity Rank
C-2	Iodine	~53	High (Flanked by Me, F)	1 (Primary)
C-5	Chlorine	~95	Low (Open position)	2 (Latent)
C-3	Fluorine	~110	High	3 (Inert*)

*Note: C-F activation requires specialized Ni-catalysts and is inert under standard Pd-conditions.

The "Ortho-Ortho" Challenge

The C2-Iodine is sandwiched between C1-Methyl and C3-Fluorine.

- Impact on Oxidative Addition: Minimal. The C-I bond is weak enough that Pd(0) inserts readily.
- Impact on Transmetalation: Critical. The incoming nucleophile (boronic acid/ester) encounters severe repulsion from the flanking groups.
- Impact on Reductive Elimination: High. Once the biaryl complex forms, the steric bulk actually accelerates product release (relief of strain), provided the ligand is bulky enough to enforce a mono-ligated Pd species.

Visualizing the Chemoselectivity

The following diagram illustrates the kinetic selectivity. The catalyst preferentially inserts into the C-I bond (Path A), leaving the C-Cl bond intact for secondary library generation (Path B).

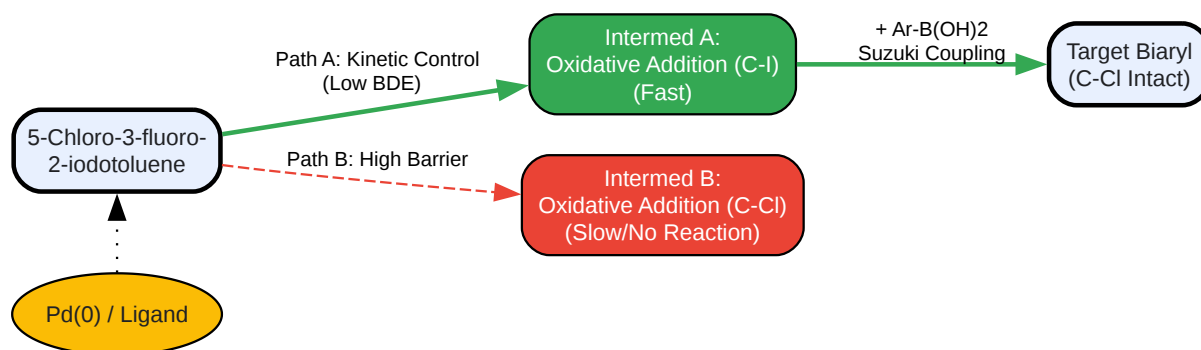

[Click to download full resolution via product page](#)

Caption: Kinetic preference for C-I insertion allows for the preservation of the C-Cl handle for subsequent elaboration.

Detailed Experimental Protocols

Protocol A: Suzuki-Miyaura Coupling (Standard)

Best for: Stable boronic acids, standard biaryl synthesis.

Critical Reagent Selection:

- Ligand: SPhos (2-Dicyclohexylphosphino-2',6'-dimethoxybiphenyl) or XPhos.
 - Why? Standard PPh₃ fails here. SPhos provides an electron-rich center to facilitate oxidative addition and, crucially, its bulk creates a "pocket" that accommodates the ortho-substituted substrate while promoting reductive elimination.
- Base: Potassium Phosphate Tribasic (K₃PO₄).
 - Why? Mild enough to prevent dehalogenation of the C-Cl, but strong enough to activate the boronic acid.

Step-by-Step Procedure:

- Setup: Flame-dry a 2-neck round bottom flask or reaction vial equipped with a magnetic stir bar.

- Charging: Add **5-Chloro-3-fluoro-2-iodotoluene** (1.0 equiv), Aryl Boronic Acid (1.2 - 1.5 equiv), Pd(OAc)₂ (2-5 mol%), and SPhos (4-10 mol%).
 - Note: A Pd:Ligand ratio of 1:2 is recommended. Alternatively, use precatalyst XPhos Pd G2 (2-5 mol%) for higher reproducibility.
- Base Addition: Add K₃PO₄ (2.0 - 3.0 equiv).
- Solvent: Add a degassed mixture of Toluene/Water (10:1) or 1,4-Dioxane/Water (4:1). Concentration should be ~0.1 M to 0.2 M.
 - Degassing: Sparge with Argon for 15 minutes. Oxygen is the enemy of active Pd-L species.
- Reaction: Seal the vessel and heat to 80–100°C for 4–12 hours.
 - QC Point: Monitor by TLC or LCMS. Look for the disappearance of the starting iodide (Rt will shift significantly).
- Workup: Cool to RT. Dilute with EtOAc. Wash with water and brine.^[1] Dry over Na₂SO₄.^[1]
- Purification: Flash chromatography. The product will likely be less polar than the boronic acid but more polar than the starting iodide.

Protocol B: Negishi Coupling (Alternative)

Best for: Base-sensitive substrates or when boronic acids are unstable/unavailable.

Step-by-Step Procedure:

- Zinc Reagent Prep: Generate the arylzinc reagent (Ar-ZnCl) by treating the corresponding aryl halide with activated Zinc dust or via transmetallation of an Aryl-Li/MgBr species with ZnCl₂ in dry THF.
- Catalyst: In a separate flask, dissolve **5-Chloro-3-fluoro-2-iodotoluene** (1.0 equiv) and Pd(PPh₃)₄ (5 mol%) or PEPPSI-IPr (2 mol%) in dry THF.
 - Note: PEPPSI catalysts are exceptionally stable and active for hindered Negishi couplings.

- Coupling: Add the Ar-ZnCl solution dropwise to the iodide solution at RT.
- Reaction: Stir at 60°C for 2–6 hours.
- Quench: Quench with saturated NH₄Cl solution (carefully).

Troubleshooting & Optimization Matrix

If conversion is low (<50%) or side products form, consult this logic table:

Observation	Probable Cause	Corrective Action
No Reaction (SM Recovery)	Catalyst death (O ₂) or Steric failure	1. Degas solvents more rigorously.2. Switch ligand from SPhos to XPhos or AdBippyPhos.3. Increase temp to 110°C (switch solvent to Xylene).
Protodehalogenation (Ar-H)	"Hydride" source present	1.[2] Ensure solvent is dry (unless water is required for base).2. Switch base to anhydrous Cs ₂ CO ₃ in Dioxane.3. Avoid alcoholic solvents.
C-Cl Activation (Mix of products)	Catalyst too aggressive	1. Lower temperature to 60°C.2. Reduce catalyst loading.3. Ensure stoichiometry of Boronic acid is not >1.5 equiv.
Homocoupling of Boronic Acid	Oxidative coupling	1. Strictly exclude O ₂ .2. Change base to K ₂ CO ₃ .

Workflow Visualization

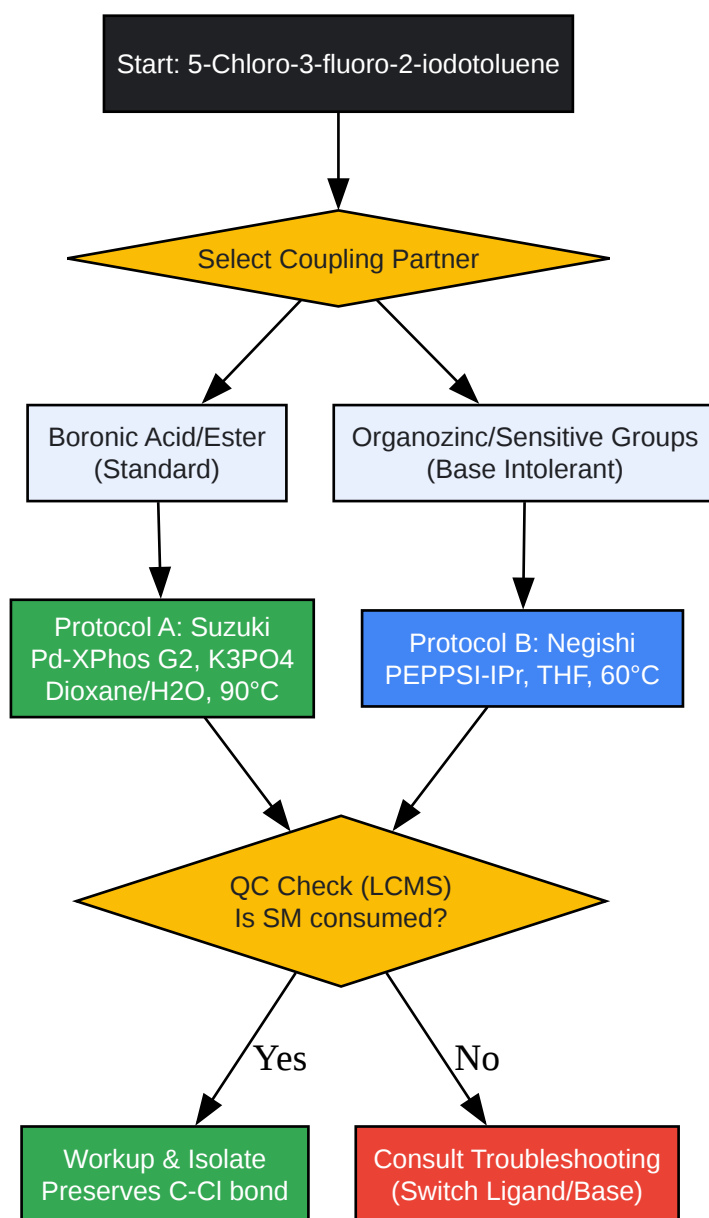

[Click to download full resolution via product page](#)

Caption: Decision tree for selecting the optimal coupling protocol based on substrate compatibility.

References

- Barder, T. E., Walker, S. D., Martinelli, J. R., & Buchwald, S. L. (2005). Catalysts for Suzuki-Miyaura Coupling Processes: Scope and Studies of the Effect of Ligand Structure. *Journal of the American Chemical Society*. [\[Link\]](#)

- Context: Establishes SPhos/XPhos as superior ligands for hindered biaryl synthesis.
- Miyaura, N., & Suzuki, A. (1995). Palladium-Catalyzed Cross-Coupling Reactions of Organoboron Compounds. Chemical Reviews. [[Link](#)]
 - Context: Foundational text on the mechanism and chemoselectivity of the Suzuki reaction.
- Organ, M. G., Avola, S., Dubovyk, I., Hadei, N., Assen, E. B., Kantchev, C. J., ... & Valente, C. (2006). A User-Friendly, All-Purpose Pd-NHC (PEPPSI) Precatalyst. Chemistry – A European Journal. [[Link](#)]
 - Context: Protocol for using PEPPSI catalysts in Negishi couplings of hindered halides.
- Littke, A. F., & Fu, G. C. (2002). Palladium-Catalyzed Coupling Reactions of Aryl Chlorides. Angewandte Chemie International Edition. [[Link](#)]
 - Context: Discusses the reactivity hierarchy of halogens (I > Br > Cl)

Need Custom Synthesis?

BenchChem offers custom synthesis for rare earth carbides and specific isotopic labeling.

Email: info@benchchem.com or [Request Quote Online](#).

Sources

- [1. pdf.benchchem.com](https://pdf.benchchem.com) [pdf.benchchem.com]
- [2. Organic Syntheses Procedure](https://orgsyn.org) [orgsyn.org]
- To cite this document: BenchChem. [synthesis of biaryls using 5-Chloro-3-fluoro-2-iodotoluene intermediate]. BenchChem, [2026]. [Online PDF]. Available at: [<https://www.benchchem.com/product/b3308847/docs#synthesis-of-biaryls-using-5-chloro-3-fluoro-2-iodotoluene-intermediate>]

Disclaimer & Data Validity:

The information provided in this document is for Research Use Only (RUO) and is strictly not intended for diagnostic or therapeutic procedures. While BenchChem strives to provide

accurate protocols, we make no warranties, express or implied, regarding the fitness of this product for every specific experimental setup.

Technical Support: The protocols provided are for reference purposes. Unsure if this reagent suits your experiment?

Need Industrial/Bulk Grade? [Request Custom Synthesis Quote](#)

BenchChem

Our mission is to be the trusted global source of essential and advanced chemicals, empowering scientists and researchers to drive progress in science and industry.

Contact

Address: 3281 E Guasti Rd

Ontario, CA 91761, United States

Phone: (601) 213-4426

Email: info@benchchem.com

[Contact our Ph.D. Support Team for a compatibility check](#)