

Technical Support Center: Synthesis of N-(3-bromophenyl)cyclopentanecarboxamide

Author: BenchChem Technical Support Team. **Date:** May 2026

Compound of Interest

Compound Name: N-(3-bromophenyl)cyclopentanecarboxamide

Cat. No.: B330198

[Get Quote](#)

Welcome to the dedicated technical support center for the synthesis of **N-(3-bromophenyl)cyclopentanecarboxamide**. This guide is designed for researchers, scientists, and drug development professionals to navigate the common challenges and optimize the yield and purity of this important synthetic transformation. Here, we move beyond simple protocols to explain the underlying chemical principles, helping you make informed decisions in your laboratory work.

I. Troubleshooting Guide: Common Issues and Solutions

This section addresses specific experimental issues in a question-and-answer format, providing both corrective actions and preventative measures.

Q1: My reaction yield is consistently low. What are the most likely causes and how can I improve it?

A1: Low yield in this amide coupling reaction typically stems from one of three main areas: inefficient activation of the carboxylic acid, poor nucleophilicity of the amine, or suboptimal reaction conditions.

- Inefficient Carboxylic Acid Activation: The direct reaction between a carboxylic acid and an amine is generally unfavorable due to a competing acid-base reaction that forms a non-reactive ammonium carboxylate salt.^{[1][2][3]} To overcome this, the carboxylic acid's carbonyl group must be "activated" to make it more electrophilic.
 - Solution 1: Acyl Chloride Intermediate. Convert cyclopentanecarboxylic acid to cyclopentanecarbonyl chloride using a chlorinating agent like thionyl chloride (SOCl₂) or oxalyl chloride.^[1] The resulting acyl chloride is highly reactive towards the amine. This is often referred to as the Schotten-Baumann reaction.^{[1][4][5][6][7]}
 - Solution 2: Use of Coupling Agents. Employ a coupling agent such as a carbodiimide.^{[8][9]} Reagents like N,N'-dicyclohexylcarbodiimide (DCC) or 1-ethyl-3-(3-dimethylaminopropyl)carbodiimide (EDC) react with the carboxylic acid to form a highly reactive O-acylisourea intermediate, which is then readily attacked by the 3-bromoaniline.^{[1][12]}
- Reduced Nucleophilicity of 3-Bromoaniline: The bromine atom on the aniline ring is an electron-withdrawing group, which reduces the electron density on the nitrogen atom, making it a less effective nucleophile compared to aniline itself.^[13]
 - Solution: Base Selection. The choice of base is critical. For the Schotten-Baumann approach, an aqueous base like NaOH or a tertiary amine like triethylamine (TEA) or pyridine is used to neutralize the HCl generated during the reaction, preventing it from protonating the starting amine.^{[1][5][6]} For coupling agent methods, a non-nucleophilic base like N,N-diisopropylethylamine (DIPEA) is often preferred to scavenge any acid without competing in the reaction.^[14]
- Suboptimal Reaction Conditions:
 - Solution: Temperature and Solvent. The reaction is typically performed at room temperature or slightly below (0 °C to RT).^{[1][4]} Using an aprotic solvent like dichloromethane (DCM), tetrahydrofuran (THF), or N,N-dimethylformamide (DMF) is

standard.[1][14][15] DMF can sometimes accelerate sluggish reactions due to its high polarity.[14]

Q2: I am observing significant amounts of unreacted 3-bromoaniline in my crude product. What's going wrong?

A2: This indicates an incomplete reaction. Assuming your reagents are pure, the issue likely lies with the stoichiometry or the activation step.

- **Stoichiometry:** Ensure you are using at least a 1:1 molar ratio of your activated carboxylic acid (or carboxylic acid with coupling agent) to the amine. It is common practice to use a slight excess (1.05-1.2 equivalents) of the acylating agent to ensure the complete consumption of the valuable amine.
- **Activation Issues:** If using a coupling agent like DCC or EDC, ensure it is fresh and has been stored under anhydrous conditions. These reagents are moisture-sensitive. The addition of additives like 1-hydroxybenzotriazole (HOBt) can improve the efficiency of carbodiimide-mediated couplings, especially with less reactive amines, by forming a more stable activated ester intermediate.[8][13]

Q3: My final product is difficult to purify. I see a persistent impurity that is hard to remove by column chromatography.

A3: The most common and troublesome impurity in DCC-mediated reactions is the N,N'-dicyclohexylurea (DCU) byproduct.[8][9]

- **Problem:** DCU is poorly soluble in many organic solvents and can co-elute with the product or even precipitate during the reaction, making filtration and purification challenging.[8][9]
- **Solution 1: Filtration.** Most of the DCU can be removed by simple filtration of the reaction mixture before workup. Chilling the reaction mixture can sometimes help to precipitate more of the urea.
- **Solution 2: Use a Water-Soluble Carbodiimide.** Switch from DCC to EDC. The corresponding urea byproduct from EDC is water-soluble and can be easily removed during an aqueous

workup.[8] This is a highly effective strategy for simplifying purification.

- Solution 3: Alternative Coupling Reagents. Reagents like HATU (1-[Bis(dimethylamino)methylene]-1H-1,2,3-triazolo[4,5-b]pyridinium 3-oxid hexafluorophosphate) are highly efficient and their byproducts are generally water-soluble and easy to remove.[14][16]

II. Frequently Asked Questions (FAQs)

Q: Which method is better: the acyl chloride (Schotten-Baumann) route or a coupling agent-based approach?

A: The "better" method depends on the scale of your reaction and the sensitivity of your starting materials.

- Acyl Chloride (Schotten-Baumann) Method:
 - Pros: This is a cost-effective and classic method that is often high-yielding.[5][7] The reagents (e.g., SOCl_2) are inexpensive.
 - Cons: The generation of acyl chlorides can involve harsh reagents and produces HCl as a byproduct, which may not be suitable for substrates with acid-sensitive functional groups. [10] The acyl chloride may also need to be isolated before reacting with the amine.[1]
- Coupling Agent Method:
 - Pros: These reactions are typically performed in one pot under mild conditions, making them suitable for complex molecules with sensitive functional groups.[10][17] There is a wide variety of coupling reagents available to optimize the reaction.[16]
 - Cons: Coupling agents can be expensive, and some, like DCC, produce byproducts that complicate purification.[9]

For general laboratory scale, the EDC/HOBt coupling method often provides a good balance of high yield, mild conditions, and straightforward purification.

Q: Can I use a base other than DIPEA or Triethylamine?

A: Yes. For Schotten-Baumann conditions, an inorganic base like sodium hydroxide or sodium carbonate in a biphasic system (e.g., DCM/water) is common.^{[4][5][7]} For coupling reactions, other hindered organic bases can be used. The key is that the base should be non-nucleophilic to avoid reacting with the activated carboxylic acid. Pyridine can also be used, acting as both a base and a nucleophilic catalyst.^{[1][6]}

Q: How do I monitor the progress of the reaction?

A: Thin Layer Chromatography (TLC) is the most common method. Spot the reaction mixture against your starting materials (3-bromoaniline and cyclopentanecarboxylic acid). The disappearance of the limiting reagent (usually the amine) and the appearance of a new, typically less polar, product spot indicates the reaction is proceeding. A suitable mobile phase might be a mixture of hexanes and ethyl acetate (e.g., 7:3 or 5:5 v/v).

III. Recommended Experimental Protocol

This protocol details a reliable method for the synthesis of **N-(3-bromophenyl)cyclopentanecarboxamide** using EDC and HOBt, which is designed to maximize yield and simplify purification.

Materials:

- Cyclopentanecarboxylic acid
- 3-Bromoaniline
- 1-Ethyl-3-(3-dimethylaminopropyl)carbodiimide (EDC)
- 1-Hydroxybenzotriazole (HOBt)
- N,N-Diisopropylethylamine (DIPEA)
- Dichloromethane (DCM), anhydrous
- 1 M Hydrochloric Acid (HCl)
- Saturated Sodium Bicarbonate (NaHCO_3) solution

- Brine (saturated NaCl solution)
- Anhydrous Magnesium Sulfate (MgSO₄) or Sodium Sulfate (Na₂SO₄)

Procedure:

- To a dry round-bottom flask under a nitrogen atmosphere, add cyclopentanecarboxylic acid (1.0 eq).
- Dissolve the acid in anhydrous DCM (approx. 0.1 M concentration).
- Add HOBt (1.1 eq) and 3-bromoaniline (1.05 eq) to the solution.
- Cool the mixture to 0 °C using an ice bath.
- Add DIPEA (1.5 eq) to the stirred solution.
- Slowly add EDC (1.2 eq) portion-wise over 5 minutes.
- Allow the reaction to warm to room temperature and stir for 12-18 hours. Monitor the reaction progress by TLC.
- Once the reaction is complete, dilute the mixture with DCM.
- Transfer the mixture to a separatory funnel and wash sequentially with 1 M HCl (2x), saturated NaHCO₃ solution (2x), and brine (1x).
- Dry the organic layer over anhydrous MgSO₄ or Na₂SO₄, filter, and concentrate the solvent under reduced pressure using a rotary evaporator.
- The resulting crude solid can be purified by recrystallization (e.g., from ethanol/water or ethyl acetate/hexanes) or by flash column chromatography on silica gel to yield the pure **N-(3-bromophenyl)cyclopentanecarboxamide**.[\[15\]](#)[\[18\]](#)[\[19\]](#)

IV. Data Summary and Visualization

Table 1: Comparison of Common Amide Synthesis Methods

| Method | Activating Agent | Typical Base | Pros | Cons |
|-------------------|--|---------------------|--|-----------------------------------|
| Schotten-Baumann | SOCl ₂ or (COCl) ₂ | Pyridine, TEA, NaOH | Cost-effective, High-yielding | Harsh reagents, HCl byproduct |
| DCC Coupling | DCC | DMAP, DIPEA | High activation | Insoluble urea byproduct (DCU) |
| EDC/HOBt Coupling | EDC, HOBt | DIPEA, TEA | Mild, One-pot, Water-soluble byproduct | Higher cost than Schotten-Baumann |
| HATU Coupling | HATU | DIPEA | Very efficient, Fast, Mild | Expensive |

Diagrams

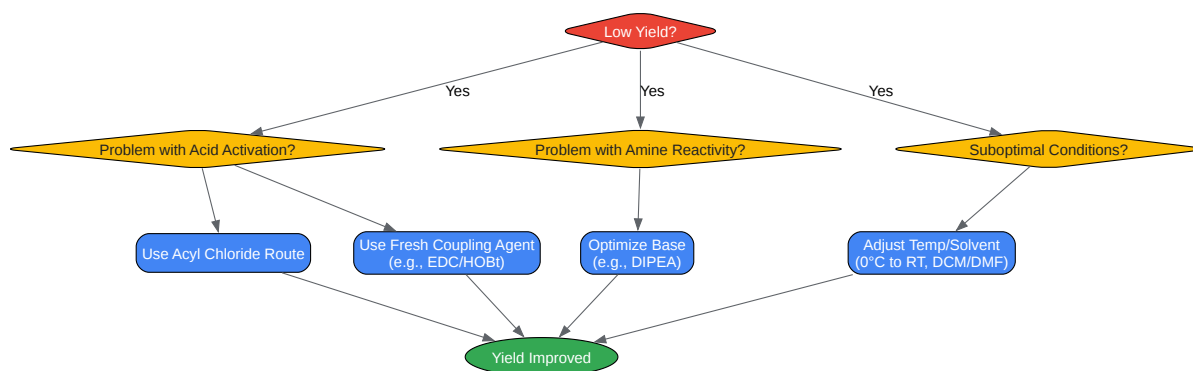
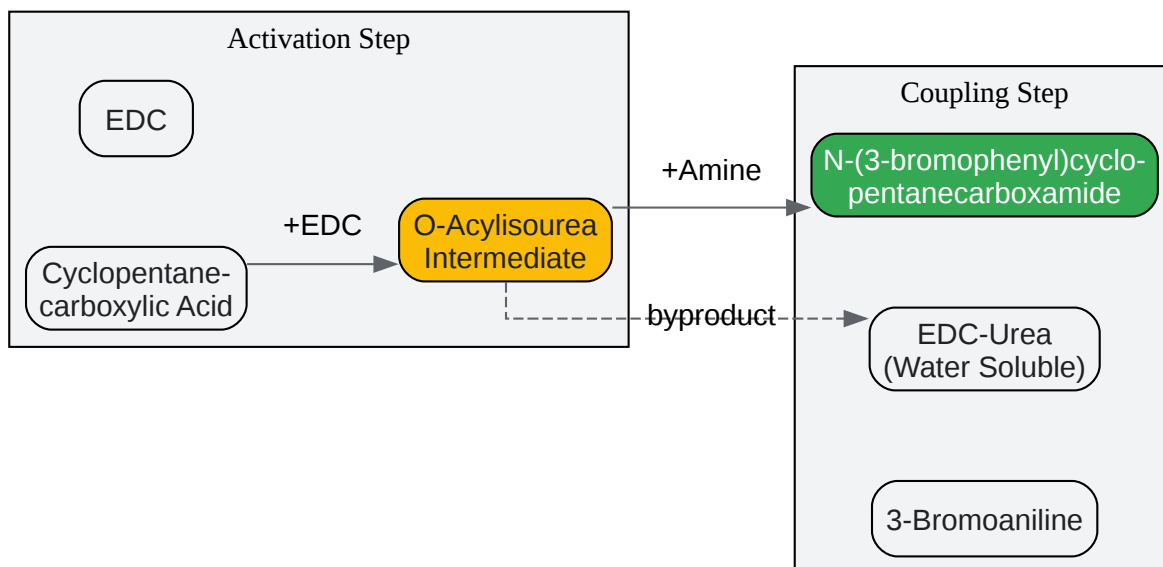

[Click to download full resolution via product page](#)

Caption: Troubleshooting workflow for low reaction yield.

V. References

- AAPPTEC. (n.d.). Coupling Reagents - AAPPTEC - Peptides. Retrieved from [\[Link\]](#)
- Wikipedia. (2023, October 27). Carbodiimide. Retrieved from [\[Link\]](#)
- Chemistry Steps. (2025, November 29). Amides from Carboxylic Acids-DCC and EDC Coupling. Retrieved from [\[Link\]](#)
- HepatoChem, Inc. (n.d.). Amide coupling reaction in medicinal chemistry. Coupling reagents. Retrieved from [\[Link\]](#)
- Taylor & Francis. (n.d.). Carbodiimide – Knowledge and References. Retrieved from [\[Link\]](#)
- SATHEE. (n.d.). Chemistry Schotten Baumann Reaction. Retrieved from [\[Link\]](#)
- Organic Chemistry Portal. (n.d.). Schotten-Baumann Reaction. Retrieved from [\[Link\]](#)
- Bobbili, V. V., et al. (2021). Convenient synthesis, characterization and biological evaluation of novel 1-phenylcyclopropane carboxamide derivatives. PLoS ONE, 16(8), e0255813. Retrieved from [\[Link\]](#)
- Lokey Lab Protocols - Wikidot. (2017, March 7). Schotten-Baumann Reaction. Retrieved from [\[Link\]](#)
- ResearchGate. (n.d.). Optimization of the reaction conditions a Catalysts. b Brominating reagents. Retrieved from [\[Link\]](#)
- Wikipedia. (2020, August 1). Schotten–Baumann reaction. Retrieved from [\[Link\]](#)
- Gunda, P., et al. (2021). Synthesis of amide derivatives for electron deficient amines and functionalized carboxylic acids using EDC and DMAP and a catalytic amount of HOBT as the coupling reagents. Tetrahedron Letters, 62, 152739. Retrieved from [\[Link\]](#)
- Growing Science. (2022, August 29). Process optimization for acid-amine coupling: a catalytic approach. Current Chemistry Letters. Retrieved from [\[Link\]](#)

- Technology Networks. (2023, February 16). Optimized Amide Bond Reaction Using Heterocyclic Compounds and Carboxylic Acid. Retrieved from [\[Link\]](#)
- Fisher Scientific. (n.d.). Amide Synthesis. Retrieved from [\[Link\]](#)
- Beilstein-Institut. (2025, May 22). Recent total synthesis of natural products leveraging a strategy of enamide cyclization. Retrieved from [\[Link\]](#)
- Organic Syntheses. (n.d.). A 1000-mL single-necked, round-bottomed flask equipped with a 7 cm magnetic stir bar... Retrieved from [\[Link\]](#)
- PrepChem.com. (n.d.). Synthesis of phenyl N-(3-bromophenyl)carbamate. Retrieved from [\[Link\]](#)
- Google Patents. (n.d.). WO2008079380A1 - Process for the preparation and isolation of the individual stereoisomers of 1-amino, 3-substituted phenylcyclopentane carboxylates. Retrieved from
- National Center for Biotechnology Information. (n.d.). Optimization of Cyclophilin B-Targeted Tri-vector Inhibitors for Novel MASH Treatments. Retrieved from [\[Link\]](#)
- Organic Syntheses. (n.d.). synthesis of unsymmetrical biaryls using a modified suzuki cross-coupling. Retrieved from [\[Link\]](#)
- CHIMIA. (n.d.). The Synthesis of Sterically Hindered Amides. Retrieved from [\[Link\]](#)
- Organic Chemistry Portal. (n.d.). Cyclopentane synthesis. Retrieved from [\[Link\]](#)
- ChemRxiv. (n.d.). Discovery and Optimization of a Novel Carboxamide Scaffold with Selective Antimalarial Activity. Retrieved from [\[Link\]](#)
- MDPI. (2024, September 20). Facile Synthesis of N-(4-Bromo-3-methylphenyl)pyrazine-2-carboxamide Derivatives... Retrieved from [\[Link\]](#)
- NINGBO INNO PHARMCHEM CO.,LTD. (2026, February 14). Mastering 3-Bromopentane: A Deep Dive into Its Synthesis and Industrial Applications. Retrieved from [\[Link\]](#)

- Science and Education Publishing. (2015, March 10). Greener Synthesis of an Amide by Direct Reaction of an Acid and Amine under Catalytic Conditions. Retrieved from [\[Link\]](#)
- Arabian Journal of Chemistry. (2021, February 23). Synthesis of N-arylamides via amination of aryltriazenes with acetonitrile under metal-free and mild conditions. Retrieved from [\[Link\]](#)
- Organic Chemistry Portal. (n.d.). Amide synthesis by acylation. Retrieved from [\[Link\]](#)
- National Center for Biotechnology Information. (n.d.). Concise synthesis of N-thiomethyl benzimidazoles through base-promoted sequential multicomponent assembly. Retrieved from [\[Link\]](#)
- Master Organic Chemistry. (2018, February 28). The Amide Functional Group: Properties, Synthesis, and Nomenclature. Retrieved from [\[Link\]](#)
- Google Patents. (2007, December 21). (12) United States Patent. Retrieved from [\[Link\]](#)
- The Royal Society of Chemistry. (n.d.). Nitrilation of Carboxylic Acids by PIII/PV Catalysis. Retrieved from [\[Link\]](#)

Need Custom Synthesis?

BenchChem offers custom synthesis for rare earth carbides and specific isotopic labeling.

Email: info@benchchem.com or [Request Quote Online](#).

Sources

1. Lab Reporter [fishersci.co.uk]
2. Greener Synthesis of an Amide by Direct Reaction of an Acid and Amine under Catalytic Conditions [pubs.sciepub.com]
3. masterorganicchemistry.com [masterorganicchemistry.com]
4. SATHEE: Chemistry Schotten Baumann Reaction [sathee.iitk.ac.in]
5. Schotten-Baumann Reaction [organic-chemistry.org]
6. jk-sci.com [jk-sci.com]

- [7. lscollge.ac.in \[lscollge.ac.in\]](https://lscollge.ac.in)
- [8. peptide.com \[peptide.com\]](https://peptide.com)
- [9. Carbodiimide - Wikipedia \[en.wikipedia.org\]](https://en.wikipedia.org)
- [10. hepatochem.com \[hepatochem.com\]](https://hepatochem.com)
- [11. taylorandfrancis.com \[taylorandfrancis.com\]](https://taylorandfrancis.com)
- [12. Amides from Carboxylic Acids-DCC and EDC Coupling - Chemistry Steps \[chemistrysteps.com\]](https://chemistrysteps.com)
- [13. Synthesis of amide derivatives for electron deficient amines and functionalized carboxylic acids using EDC and DMAP and a catalytic amount of HOBT as the coupling reagents - PMC \[pmc.ncbi.nlm.nih.gov\]](https://pubmed.ncbi.nlm.nih.gov)
- [14. Convenient synthesis, characterization and biological evaluation of novel 1-phenylcyclopropane carboxamide derivatives - PMC \[pmc.ncbi.nlm.nih.gov\]](https://pubmed.ncbi.nlm.nih.gov)
- [15. mdpi.com \[mdpi.com\]](https://mdpi.com)
- [16. One moment, please... \[growingscience.com\]](https://growingscience.com)
- [17. asiaresearchnews.com \[asiaresearchnews.com\]](https://asiaresearchnews.com)
- [18. Organic Syntheses Procedure \[orgsyn.org\]](https://orgsyn.org)
- [19. pdf.benchchem.com \[pdf.benchchem.com\]](https://pdf.benchchem.com)
- To cite this document: BenchChem. [Technical Support Center: Synthesis of N-(3-bromophenyl)cyclopentanecarboxamide]. BenchChem, [2026]. [Online PDF]. Available at: [\[https://www.benchchem.com/product/b330198/docs#technical-support-center-synthesis-of-n-3-bromophenyl-cyclopentanecarboxamide\]](https://www.benchchem.com/product/b330198/docs#technical-support-center-synthesis-of-n-3-bromophenyl-cyclopentanecarboxamide)

Disclaimer & Data Validity:

The information provided in this document is for Research Use Only (RUO) and is strictly not intended for diagnostic or therapeutic procedures. While BenchChem strives to provide accurate protocols, we make no warranties, express or implied, regarding the fitness of this product for every specific experimental setup.

Technical Support: The protocols provided are for reference purposes. Unsure if this reagent suits your experiment?

Need Industrial/Bulk Grade? [Request Custom Synthesis Quote](#)

BenchChem

Our mission is to be the trusted global source of essential and advanced chemicals, empowering scientists and researchers to drive progress in science and industry.

Contact

Address: 3281 E Guasti Rd

Ontario, CA 91761, United States

Phone: (601) 213-4426

Email: info@benchchem.com

[Contact our Ph.D. Support Team for a compatibility check](#)