

Application Note: Regioselective Synthesis of 5-Chloro-2-ethoxypyridine-3-carbaldehyde

Author: BenchChem Technical Support Team. **Date:** April 2026

Compound of Interest

Compound Name: *5-Chloro-2-ethoxy-pyridine-3-carbaldehyde*

CAS No.: *870721-63-4*

Cat. No.: *B3291212*

[Get Quote](#)

Executive Summary & Strategic Analysis

The synthesis of 5-chloro-2-ethoxypyridine-3-carbaldehyde (Target) from 2,5-dichloropyridine (SM) presents a classic problem in pyridine regioselectivity. The target molecule requires two distinct functionalizations:

- Nucleophilic substitution of a chloride with an ethoxy group.
- Formylation (introduction of an aldehyde) at the C3 position.

Route Selection: The "SnAr-First" Advantage

While multiple routes exist, this guide advocates for the Nucleophilic Aromatic Substitution (SnAr) followed by Directed Ortho Metalation (DoM) pathway.

- Route A (Lithiation

SnAr): Lithiation of 2,5-dichloropyridine typically occurs at C4 (kinetic) or C3/C4 mixtures, leading to difficult separations. Subsequent SnAr is less selective due to competing activation from the newly installed aldehyde.

- Route B (SnAr

Lithiation): This is the preferred protocol.

- Step 1 (SnAr): The C2-chloride is highly activated by the adjacent ring nitrogen, allowing exclusive substitution over the C5-chloride.
- Step 2 (DoM): The newly installed ethoxy group (-OEt) at C2 acts as a powerful Directed Ortho Metalation group (DMG), chelating lithium and directing deprotonation exclusively to the C3 position.

Reaction Scheme Visualization

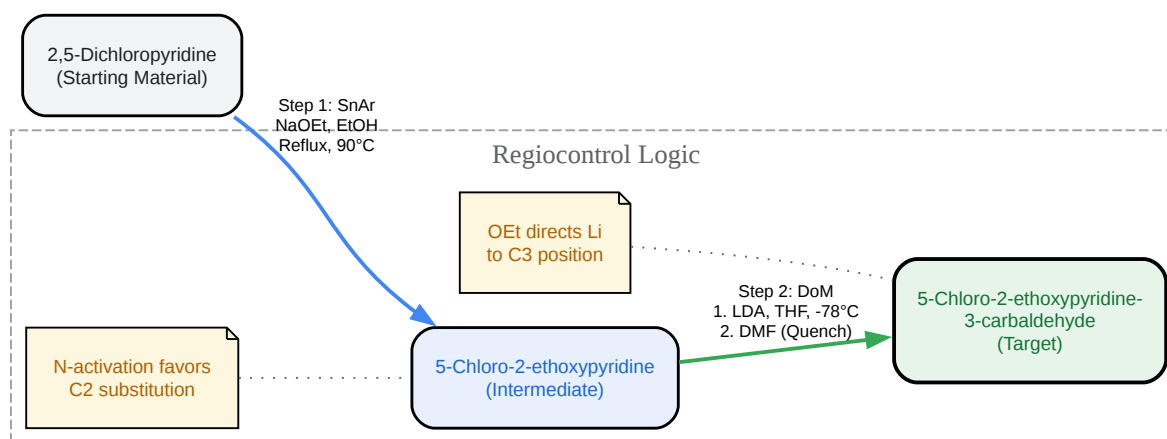

[Click to download full resolution via product page](#)

Figure 1: Strategic workflow for the regioselective synthesis of the target aldehyde. The pathway leverages intrinsic electronic biases (N-activation) and chelation effects (DoM) to ensure high isomer purity.

Detailed Experimental Protocols

Step 1: Preparation of 5-Chloro-2-ethoxypyridine

This step utilizes the high electrophilicity of the C2 position. The reaction is robust and typically proceeds with >90% regioselectivity.

Reagents:

- 2,5-Dichloropyridine (1.0 eq)
- Sodium Ethoxide (2.0 eq) [Prepared in situ or commercial solution]
- Ethanol (anhydrous)

Protocol:

- Setup: Charge a flame-dried round-bottom flask equipped with a magnetic stir bar and a reflux condenser with anhydrous ethanol under an inert atmosphere (or Ar).
- Base Preparation: Add Sodium Ethoxide (21% wt in EtOH or solid) to the flask.
 - Note: If using NaH + EtOH, ensure H₂ evolution ceases before adding substrate.
- Addition: Add 2,5-Dichloropyridine (1.0 eq) to the ethoxide solution at room temperature. The reaction may be slightly exothermic.
- Reaction: Heat the mixture to reflux (approx. 80-90°C) for 12–20 hours.
 - Monitoring: Monitor by TLC (Hexane:EtOAc 9:1) or HPLC.^{[2][3][4]} The starting material (SM) should disappear; the product is more polar than the SM but less polar than the bis-ethoxy byproduct (rare).
- Workup:
 - Cool the mixture to room temperature.

- Concentrate under reduced pressure to remove most ethanol.
- Dilute the residue with water and extract with Ethyl Acetate ().^[5]
- Wash combined organics with Brine, dry over , and concentrate.
- Purification: The crude oil is often sufficiently pure (>95%) for the next step. If necessary, purify via vacuum distillation or flash chromatography (, 0-5% EtOAc in Hexanes).

Key Mechanistic Insight: The nitrogen atom in the pyridine ring withdraws electron density, making the C2 and C6 positions susceptible to nucleophilic attack. Since C2 bears a leaving group (Cl) and C6 does not, substitution occurs exclusively at C2. The C5-Cl is deactivated (meta to N) and remains intact.

Step 2: Synthesis of 5-Chloro-2-ethoxypyridine-3-carbaldehyde

This step relies on Directed Ortho Metalation (DoM). The ethoxy group coordinates the lithium base, placing the anion specifically at C3.

Reagents:

- 5-Chloro-2-ethoxypyridine (Intermediate from Step 1)
- LDA (Lithium Diisopropylamide) (1.2 eq) [Freshly prepared or commercial 2.0M]
- DMF (Dimethylformamide) (1.5 eq) [Anhydrous]
- THF (Tetrahydrofuran) [Anhydrous, inhibitor-free]

Protocol:

- Cryogenic Setup: Flame-dry a 3-neck flask. Cool to -78°C (Dry ice/Acetone bath). Maintain strict anhydrous conditions.
- Base Preparation: Add anhydrous THF and LDA (1.2 eq). Stir for 10 minutes to equilibrate.
 - Why LDA? n-BuLi is nucleophilic and may attack the C6 position of the pyridine ring. LDA is a bulky, non-nucleophilic base that acts strictly as a proton scavenger.
- Lithiation: Dissolve 5-Chloro-2-ethoxypyridine in a minimum volume of THF and add it dropwise to the LDA solution over 15-30 minutes, keeping the internal temperature below -70°C .
- Chelation Time: Stir at -78°C for 1 to 2 hours.
 - Observation: The solution often turns a deep yellow or orange color, indicating the formation of the lithiated species.
- Formylation: Add anhydrous DMF (1.5 eq) dropwise.
- Warming: Stir at -78°C for 30 minutes, then remove the cooling bath and allow the reaction to warm to 0°C or Room Temperature.
- Quench: Quench the reaction with saturated aqueous
or dilute HCl (careful not to hydrolyze the ethoxy group with strong acid/heat).
- Workup: Extract with EtOAc or DCM. Wash with water (to remove DMF) and brine. Dry and concentrate.
- Purification: Recrystallize from Hexane/EtOAc or purify via column chromatography.

Mechanism of Direction (DoM)

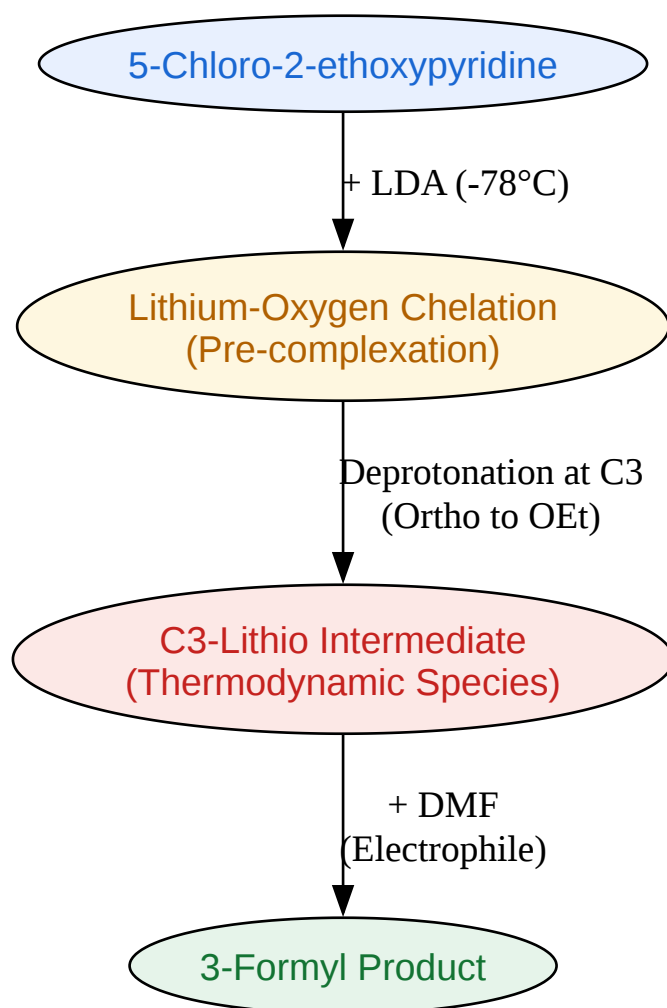

[Click to download full resolution via product page](#)

Figure 2: The ethoxy oxygen lone pair coordinates with Lithium, positioning the amide base to deprotonate the sterically accessible C3 proton.

Analytical Data & Quality Control

When validating the final product, look for these specific spectroscopic signatures:

Technique	Parameter	Expected Observation
1H NMR	Aldehyde (-CHO)	Singlet at ~10.2 - 10.4 ppm. Distinctive desheilding.
1H NMR	Pyridine Ring	Two aromatic singlets (or doublets with small J coupling). H4 and H6 will appear at different shifts.
1H NMR	Ethoxy Group	Quartet (~4.5 ppm) and Triplet (~1.4 ppm).
IR	Carbonyl (C=O)	Strong stretch at 1680 - 1700 cm ⁻¹ .
LC-MS	Mass	[M+H] ⁺ = 186.0 (approx). Look for Cl isotope pattern (3:1 ratio of M : M+2).

Safety & Handling

- Organolithiums (LDA/n-BuLi): Pyrophoric. Handle only under inert atmosphere. Ensure quench vessels are ready before starting.
- Sodium Ethoxide: Corrosive and moisture sensitive.
- Exotherms: The SnAr reaction (Step 1) can be exothermic upon mixing. The Lithiation quench (Step 2) is exothermic; add acid slowly.

References

- Regioselectivity of SnAr on Dichloropyridines
 - General Principle: 2,5-dichloropyridine undergoes substitution at C2 due to nitrogen activ
 - Patent Reference: WO 2016/022742 A1. (See Example 1, Step 1: Synthesis of 5-chloro-2-ethoxypyridine).
 - Source:

- Lithiation of 2-Alkoxy pyridines
 - Mechanism:[6][7][8] Directed Ortho Metalation (DoM) directs lithiation to the C3 position (ortho to alkoxy).
 - Scientific Context: "Regioselective ortho-lithiation of halopyridines." [2] Heterocycles, Vol 35, No 1, 1993.
 - Source:
- Product Identification
 - Compound: **5-Chloro-2-ethoxy-pyridine-3-carbaldehyde** (CAS 870721-63-4).[9]
 - Source: (Verified availability of specific isomer).
- General Review of Pyridine Functionalization: Schlosser, M. "Organometallics in Synthesis." John Wiley & Sons. (Standard text on DoM chemistry).

Need Custom Synthesis?

BenchChem offers custom synthesis for rare earth carbides and specific isotopic labeling.

Email: info@benchchem.com or [Request Quote Online](#).

Sources

- 1. pdf.benchchem.com [pdf.benchchem.com]
- 2. researchgate.net [researchgate.net]
- 3. EP1346984B1 - Process for the preparation of 2-chloro-5-methylpyridine-3- carbaldehyde - Google Patents [patents.google.com]
- 4. CN104529881B - 2-chloro-5-ethyl pyridine preparation method - Google Patents [patents.google.com]
- 5. WO2016022742A1 - Antidiabetic bicyclic compounds - Google Patents [patents.google.com]
- 6. researchgate.net [researchgate.net]

- [7. researchgate.net \[researchgate.net\]](https://www.researchgate.net)
- [8. CN101830845A - Synthesis method of 5-chloro-2,3-dihydroxyl pyridine - Google Patents \[patents.google.com\]](https://patents.google.com/patents/CN101830845A)
- [9. 870721-63-4 | 5-Chloro-2-ethoxy-pyridine-3-carbaldehyde | Boroncore \[boroncore.com\]](https://boroncore.com)
- To cite this document: BenchChem. [Application Note: Regioselective Synthesis of 5-Chloro-2-ethoxypyridine-3-carbaldehyde]. BenchChem, [2026]. [Online PDF]. Available at: [\[https://www.benchchem.com/product/b3291212/docs#application-note-regioselective-synthesis-of-5-chloro-2-ethoxypyridine-3-carbaldehyde\]](https://www.benchchem.com/product/b3291212/docs#application-note-regioselective-synthesis-of-5-chloro-2-ethoxypyridine-3-carbaldehyde)

Disclaimer & Data Validity:

The information provided in this document is for Research Use Only (RUO) and is strictly not intended for diagnostic or therapeutic procedures. While BenchChem strives to provide accurate protocols, we make no warranties, express or implied, regarding the fitness of this product for every specific experimental setup.

Technical Support: The protocols provided are for reference purposes. Unsure if this reagent suits your experiment?

Need Industrial/Bulk Grade? [Request Custom Synthesis Quote](#)

BenchChem

Our mission is to be the trusted global source of essential and advanced chemicals, empowering scientists and researchers to drive progress in science and industry.

Contact

Address: 3281 E Guasti Rd
Ontario, CA 91761, United States
Phone: (601) 213-4426
Email: info@benchchem.com

[Contact our Ph.D. Support Team for a compatibility check](#)

