

# Technical Support Center: Handling Air-Sensitive Amino Esters

**Author:** BenchChem Technical Support Team. **Date:** April 2026

## Compound of Interest

Compound Name: *tert-Butyl 3-(diethylamino)propanoate*

CAS No.: 85608-16-8

Cat. No.: B3289196

[Get Quote](#)

Welcome to the Technical Support Center dedicated to the nuanced handling of air-sensitive amino esters. This guide is designed for researchers, chemists, and drug development professionals who work with these reactive molecules. The stability and reactivity of amino esters are paramount to successful experimental outcomes, and their sensitivity to atmospheric oxygen and moisture presents a significant challenge.[1] This resource provides in-depth, field-proven insights and protocols to ensure the integrity of your compounds and the reliability of your results.

## Part 1: Fundamentals of Handling Air-Sensitive Amino Esters

This section addresses the foundational principles behind the specialized handling requirements for these compounds.

### Q1: Why are amino esters considered "air-sensitive"?

A: The "air-sensitive" nature of amino esters stems from two primary chemical vulnerabilities: the nucleophilic amino group and the electrophilic ester group.

- **Oxidation of the Amino Group:** The lone pair of electrons on the nitrogen atom of the primary or secondary amine makes it susceptible to oxidation by atmospheric oxygen. This can lead to the formation of various undesired byproducts, such as nitroso compounds or colored degradation products, which can complicate reactions and purification. While many simple amino esters are stable enough for benchtop handling over short periods, prolonged exposure or the presence of sensitive functional groups necessitates inert atmosphere techniques.
- **Hydrolysis of the Ester Group:** The ester functional group is susceptible to hydrolysis, a reaction with water (moisture from the air) that cleaves the ester back into a carboxylic acid and an alcohol. This reaction can be catalyzed by acidic or basic impurities and accelerated by heat. Inappropriate handling and storage can lead to product degradation over time, which is often difficult to detect but can significantly impact experimental results.[2]
- **Reactivity with Carbon Dioxide:** The free amino group can react with carbon dioxide from the air to form carbamates, introducing another potential impurity.

The combination of these potential degradation pathways requires that these reagents be handled with care to exclude both oxygen and moisture.[3]

## Q2: What is an "inert atmosphere," and which gas should I use—Argon or Nitrogen?

A: An inert atmosphere is an environment from which reactive gases, primarily oxygen and water vapor, have been removed and replaced with a non-reactive gas.[4] The two most common choices in the laboratory are nitrogen ( $N_2$ ) and argon (Ar).[5] The choice between them depends on a balance of cost, required inertness, and the specific reaction conditions.

Feature	Nitrogen (N <sub>2</sub> )	Argon (Ar)	Rationale & Recommendation
Cost	Less expensive	More expensive	For most standard procedures involving amino esters, nitrogen is the more economical and perfectly suitable choice. <sup>[5]</sup>
Density	Lighter than air	~1.4 times denser than air	Argon's higher density makes it more effective at displacing air from a reaction vessel, providing a superior "blanket" of protection, especially in systems that are not perfectly sealed. <sup>[5]</sup>
Reactivity	Generally inert, but can react with certain metals (e.g., lithium) at high temperatures to form nitrides.	Highly inert (noble gas)	While nitrogen's reactivity is a concern for specific organometallic reactions, it is not typically an issue for the majority of amino ester chemistry. Argon is preferred for highly sensitive systems or when working with reagents known to react with N <sub>2</sub> . <sup>[4]</sup>

Senior Scientist Recommendation: For routine handling, purification, and reactions of most amino esters, high-purity nitrogen is sufficient and cost-effective. For highly sensitive catalytic

systems or when absolute exclusion of reactive gases is critical to prevent even trace byproducts, Argon is the superior choice.

## Part 2: Essential Laboratory Setups & Protocols

Proper technique begins with the right setup. This section details the equipment and step-by-step procedures for creating and maintaining an inert environment.

**Q3: What is a Schlenk line, and what are the key principles for its use?**

**A:** A Schlenk line (or vacuum-gas manifold) is a standard piece of laboratory apparatus that allows for the safe and effective manipulation of air-sensitive compounds.<sup>[6][7]</sup> It consists of a dual glass manifold with several ports: one manifold is connected to a source of purified inert gas, and the other is connected to a vacuum pump, protected by a cold trap (typically liquid nitrogen).<sup>[7]</sup> Special dual-way stopcocks on each port allow the user to switch between applying a vacuum or an inert gas atmosphere to the attached glassware.<sup>[7]</sup>

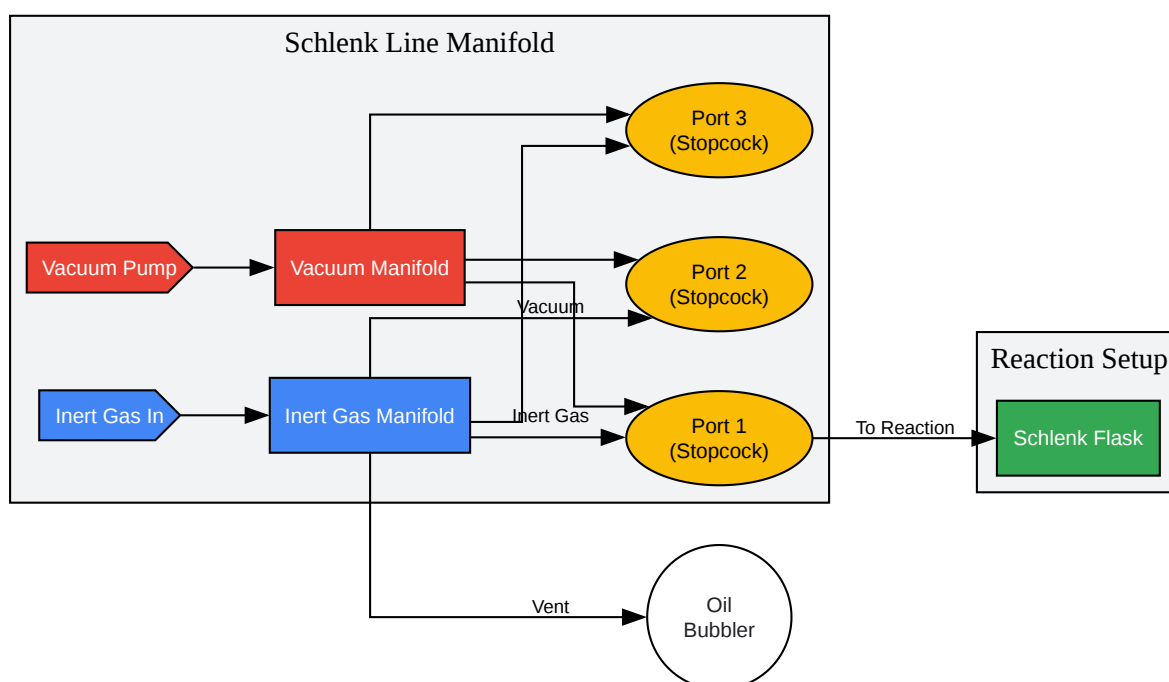

[Click to download full resolution via product page](#)

Caption: Basic schematic of a Schlenk line setup.

The core technique for making glassware air-free on a Schlenk line is the "purge-and-refill" cycle.<sup>[3]</sup> This involves evacuating the flask to remove the bulk of the air and adsorbed water, followed by refilling it with inert gas. This cycle is typically repeated at least three times to ensure the atmosphere inside the flask is sufficiently inert.<sup>[3][6]</sup>

## Protocol 1: Preparing Glassware on a Schlenk Line

- **Oven-Dry:** Thoroughly dry all glassware (reaction flask, stir bar, condensers, etc.) in an oven (e.g., >125°C for at least 4 hours, or overnight) to remove the thin film of adsorbed moisture.<sup>[8][9]</sup>
- **Assemble Hot:** While the glassware is still hot, assemble the apparatus quickly. Use a thin, uniform layer of high-vacuum grease on all ground-glass joints. Secure the joints with clips.
- **Connect to Schlenk Line:** Immediately connect the assembled, hot glassware to a port on the Schlenk line via thick-walled rubber tubing.
- **First Evacuation:** Open the stopcock on the flask to the vacuum manifold. The flask will cool under vacuum. Allow it to evacuate for several minutes. For a 100 mL flask, 5 minutes is a reasonable starting point.<sup>[6]</sup>
- **First Backfill:** Slowly and carefully, turn the stopcock to switch from the vacuum to the inert gas manifold. You should hear the gas flowing in. Never open the stopcock abruptly, as this can dislodge solid reagents or cause the oil in the bubbler to suck back.
- **Repeat Cycles:** Repeat the evacuation (Step 4) and backfill (Step 5) process at least two more times for a total of three cycles.<sup>[3]</sup> The glassware is now under a positive pressure of inert gas and ready for use.

## Q4: What is the best way to degas my reaction solvent?

A: Dissolved oxygen in solvents is a common source of reaction failure, especially in heated or long-duration experiments.<sup>[10]</sup> Removing it is critical. The best method depends on the required level of purity and the solvent's properties.

Method	Procedure	Pros	Cons	Best For
Freeze-Pump-Thaw	The solvent is frozen (liquid N <sub>2</sub> ), a vacuum is applied to remove gases from the headspace, the flask is sealed, and the solvent is thawed to release dissolved gases. This is repeated 3x.[8] [10]	Most effective method. Removes virtually all dissolved gases. [8][10][11]	Time-consuming; requires liquid nitrogen and a high-vacuum line for best results. [12]	Highly oxygen-sensitive reactions, such as those involving organometallic catalysts or radical intermediates. [10]
Sparging (Bubbling)	A stream of inert gas is bubbled through the liquid via a long needle or tube for an extended period (30-60 min).[8] [13]	Simple, fast, and does not require a vacuum. Good for large volumes.	Least effective method.[8] Reaches an equilibrium of dissolved inert gas but may not remove all oxygen. Can evaporate volatile solvents.	Reactions that are moderately air-sensitive where trace oxygen is tolerable.
Sonication & Vacuum	The solvent is subjected to several cycles of sonication under a light vacuum, followed by backfilling with inert gas.[8][10]	Faster than freeze-pump-thaw. More effective than sparging alone.	Not as thorough as freeze-pump-thaw.	Quickly preparing solvents for applications like HPLC or moderately sensitive reactions.[10]

## Protocol 2: Degassing a Solvent via Freeze-Pump-Thaw

- **Prepare the Flask:** Place the solvent in a Schlenk flask, filling it no more than halfway. Ensure the flask has a well-greased stopcock.
- **Freeze:** Immerse the bottom of the flask in a dewar of liquid nitrogen. Swirl the flask gently to freeze the solvent in a thin layer on the walls, avoiding a solid block at the bottom which can crack the flask upon thawing.<sup>[14]</sup>
- **Pump:** Once the solvent is completely frozen solid, connect the flask to a vacuum line and open the stopcock. Evacuate for 3-5 minutes.<sup>[8][10]</sup> You are removing the gases from the headspace above the frozen solid.
- **Thaw:** Close the stopcock to isolate the flask from the vacuum. Remove the liquid nitrogen dewar and allow the solvent to thaw completely. A warm water bath can be used to speed this up.<sup>[12]</sup> You will see bubbles of gas being released from the liquid as it thaws.
- **Repeat:** Repeat the entire freeze-pump-thaw cycle two more times for a total of three cycles.<sup>[8]</sup>
- **Final Backfill:** After the final cycle, backfill the flask with your chosen inert gas (N<sub>2</sub> or Ar) before the solvent thaws completely to prevent it from bumping into the vacuum line.<sup>[12]</sup> The solvent is now degassed and ready for use.

## Q5: How do I safely transfer an air-sensitive amino ester solution?

A: Transferring liquids without introducing air is a critical skill. The two primary methods are by syringe for smaller volumes and by cannula for larger volumes.

### Protocol 3: Transfer via Syringe

- **Prepare Syringe:** Dry the syringe and needle in an oven. Allow it to cool in a desiccator or by flushing with inert gas.<sup>[8][9]</sup>
- **Pressurize Source:** Puncture the septum of the reagent bottle (e.g., a Sure/Seal™ bottle) with a needle connected to your inert gas line to introduce a slight positive pressure.<sup>[9]</sup>
- **Withdraw Reagent:** Insert the needle of your prepared syringe through the septum and into the liquid. Allow the positive pressure in the bottle to slowly fill the syringe to a volume

slightly greater than needed. Do not pull back on the plunger, as this can create leaks and introduce air.[15]

- Remove Bubbles & Set Volume: Invert the syringe and push the excess reagent and any gas bubbles back into the reagent bottle.[15]
- Create Gas Buffer: With the needle tip still in the headspace of the reagent bottle, withdraw a small volume (~0.5 mL) of inert gas. This "buffer" protects the reagent in the needle from exposure to air during the transfer.[16]
- Transfer: Quickly withdraw the syringe and insert it into the septum of the receiving flask. First, inject the inert gas buffer, then slowly deliver the reagent.

#### Protocol 4: Transfer via Cannula (Double-Tipped Needle)

- Setup: Place the source flask and the receiving flask side-by-side. Both must be sealed with rubber septa and be under a positive pressure of inert gas.
- Insert Cannula: Puncture the septum of the source flask with one end of the cannula, ensuring the tip is in the headspace above the liquid. Allow inert gas to flush through the cannula for a minute.
- Vent Receiving Flask: Insert a short "venting" needle connected to a bubbler into the septum of the receiving flask. This allows pressure to escape.
- Initiate Transfer: Insert the other end of the cannula through the septum of the receiving flask. Lower the end of the cannula in the source flask into the liquid. The positive pressure in the source flask will push the liquid through the cannula into the receiving flask.[5]
- Control Flow: The flow rate can be controlled by adjusting the depth of the venting needle in the receiving flask (deeper = slower flow) or by slightly increasing the inert gas pressure in the source flask.
- Stop Transfer: Once the desired volume is transferred, raise the cannula tip above the liquid level in the source flask and allow inert gas to push the remaining liquid out of the cannula. Then, remove the cannula from both flasks.

## Part 3: Troubleshooting Guide

Even with careful technique, problems can arise. This section provides a logical framework for diagnosing and solving common issues.

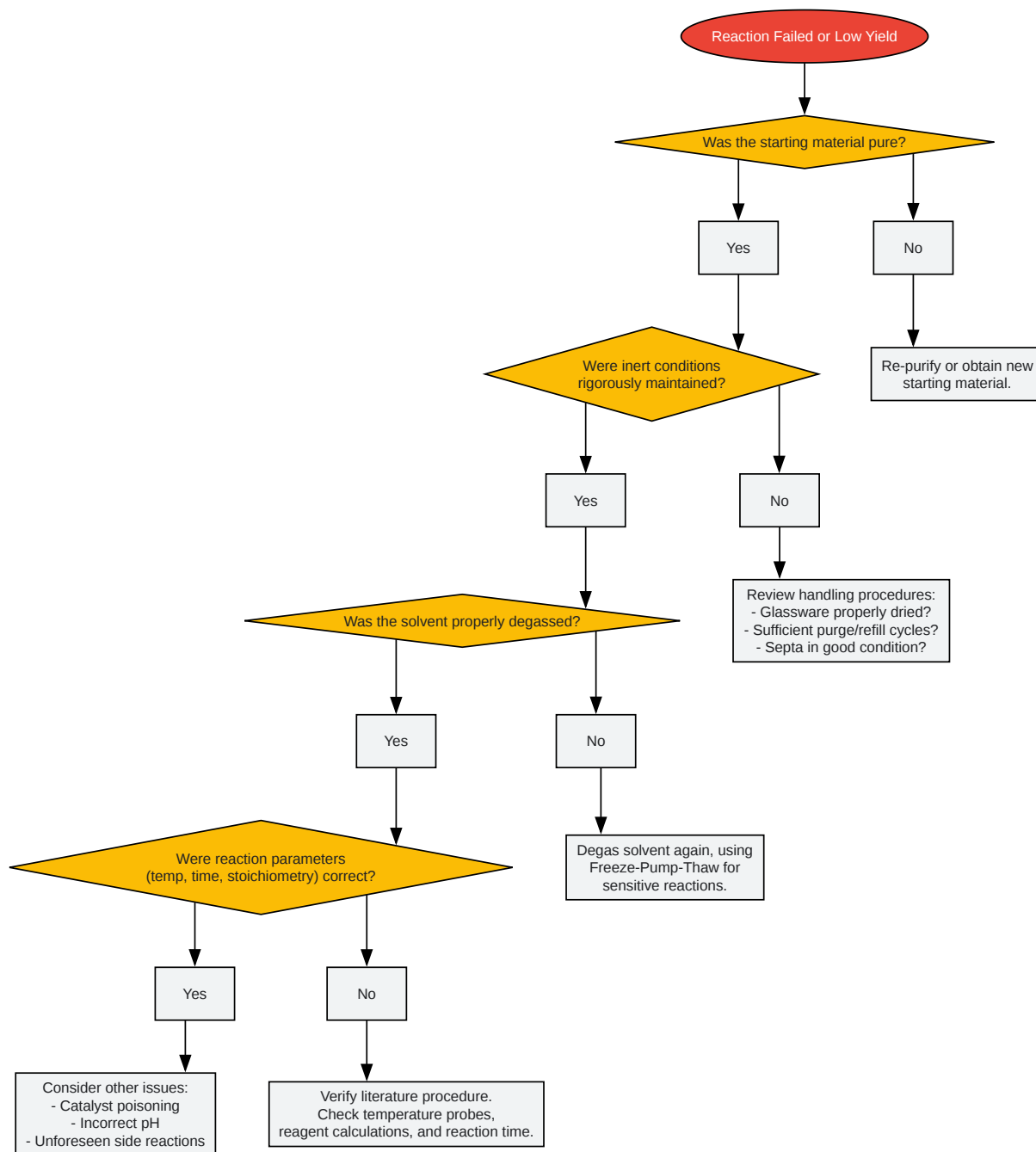

[Click to download full resolution via product page](#)

Caption: Troubleshooting flowchart for a failed reaction.

## Q6: I'm observing unexpected byproducts. What are common side reactions with amino esters?

A: Beyond simple decomposition, several side reactions can occur:

- **Hydrolysis:** As mentioned, moisture will hydrolyze the ester to the parent amino acid. This is especially problematic during aqueous workups. If your product is soluble in organic solvents, wash with brine instead of pure water and dry thoroughly with an agent like  $\text{Na}_2\text{SO}_4$  or  $\text{MgSO}_4$ .
- **Racemization:** The stereochemical integrity of chiral amino esters can be compromised, especially under basic conditions or at elevated temperatures. The  $\alpha$ -proton is acidic and can be abstracted, leading to a loss of enantiomeric purity.<sup>[17]</sup> Use mild bases and the lowest effective reaction temperature.
- **Dimerization/Polymerization:** Unprotected amino esters can potentially react with each other to form diketopiperazines (cyclic dimers) or linear polymers, especially upon heating. This is more common when attempting to generate the free base from the salt form in situ without another electrophile present.
- **Side reactions with reagents:** In syntheses involving amino esters, unwanted reactions can occur. For example, during some preparations, O-alkylation can compete with the desired reaction pathway.<sup>[18]</sup>

## Q7: My amino ester decomposed during workup or purification. How can I avoid this?

A: Workup and purification are stages of high vulnerability.

- **Aqueous Workup:** Minimize contact time with aqueous layers. Use chilled solutions and work quickly. Ensure the pH is controlled, as both strongly acidic and basic conditions can accelerate hydrolysis.
- **Solvent Removal:** Remove solvents under reduced pressure at low temperatures (i.e., use a room temperature or cool water bath for your rotovap). Do not heat aggressively.

- **Chromatography:** If flash chromatography is necessary, consider deactivating the silica gel to prevent degradation of sensitive compounds. This can be done by pre-treating the silica with a small amount of a non-nucleophilic base (like triethylamine) in the eluent. Perform the chromatography quickly.
- **Inert Atmosphere Filtration:** For isolating solid products that are air-sensitive, filtration must be done under an inert atmosphere using a Schlenk filter or by performing the filtration inside a glovebox.<sup>[6][11]</sup>

## Part 4: Frequently Asked Questions (FAQs)

### Q8: How should I properly store my air-sensitive amino ester?

A: Proper storage is essential for maintaining the compound's integrity. The best method is to store the compound in a sealed vessel under a positive pressure of inert gas.<sup>[19]</sup> Storing in a Schlenk flask with a greased stopcock or in a sealed ampoule is ideal.<sup>[1]</sup> For routine use, a Sure/Seal™ type bottle is very effective.<sup>[9][15]</sup> Always store in a cool, dry, and dark place, such as a refrigerator or freezer designated for chemicals, and allow the container to warm to room temperature before opening to prevent condensation of moisture on the cold surfaces.<sup>[19]</sup>

### Q9: Can I reuse a rubber septum?

A: It is poor practice to reuse septa for highly air-sensitive applications. Each puncture creates a potential leak path for air to enter the flask. While high-quality septa can reseal effectively after a few punctures from a small-gauge needle, they will eventually deteriorate.<sup>[19][20]</sup> For critical reactions, always use a new septum. Fold the septum over the joint for a better seal.<sup>[16]</sup>

### Q10: How do I safely quench and clean glassware?

A: Never open a flask containing residual reactive material directly to the atmosphere. After the reaction is complete and has cooled to room temperature, slowly and carefully add a quenching agent while still under an inert atmosphere. A good general practice is to add a less reactive protic solvent like isopropanol first, followed by methanol, and finally water, all while cooling the flask in an ice bath.<sup>[5]</sup> Once fully quenched, the glassware can be opened to the air and cleaned normally. Syringes and cannulas should be cleaned immediately after use by flushing with a dry, inert solvent, followed by a quenching solvent, to prevent the reagent from seizing the parts.<sup>[9]</sup>

## References

- An Illustrated Guide to Schlenk Line Techniques. (2023).
- Schlenk line - Wikipedia. Wikipedia.
- Techniques for Handling Air- and Moisture-Sensitive Compounds. (2014). Wipf Group - University of Pittsburgh.
- Air-Sensitive Chemistry: Practical and Safety Consider
- Chem 1140; Techniques for Handling Air-Sensitive Compounds. Wipf Group.
- Air Free Techniques | Handling Air-Sensitive M
- Guides - Chemistry LibreTexts. (2024). Chemistry LibreTexts.
- Procedures for Safe Use of Pyrophoric Liquid Reagents. UCLA – Chemistry and Biochemistry.
- Working with air and moisture sensitive compounds. (2008). Molecular Inorganic Chemistry.
- Application Notes and Protocols for Handling and Storage of Air-Sensitive Chlorin
- How To: Degas Solvents. Chemistry - University of Rochester.
- Degassing solvents. Chemistry Teaching Labs - University of York.
- Degassing Solvents. (2019). Berry Group.
- Solvent Degassing by Freeze-Thaw. EPFL.
- Handling Air-Sensitive Reagents Technical Bulletin AL-134. Sigma-Aldrich.
- Handling air-sensitive reagents AL-134. MIT.
- Air Sensitive Compounds. Ossila.
- Air-free technique - Wikipedia. Wikipedia.
- Storage of air and temperature sensitive reagents. (2023). Chemistry Stack Exchange.
- The Manipulation of Air-Sensitive Compounds. Thieme.
- Inert
- Transferring Methods - Inert Atmospheric Methods. (2022). Chemistry LibreTexts.
- What Methods Are Used To Implement Inert
- Technical Support Center: Synthesis of Amino Alcohol Compounds. Benchchem.
- Automated Parallel Synthesis of N-Alkylated- $\alpha$ -Amino Methyl Esters in Gram Quantities. (2005). CHIMIA.
- Synthesis of unnatural  $\alpha$ -amino esters using ethyl nitroacetate and condensation or cycloaddition reactions. (2018). Beilstein Journals.
- Handling air-sensitive reagents AL-134. Division of Research Safety.

### *Need Custom Synthesis?*

*BenchChem offers custom synthesis for rare earth carbides and specific isotopic labeling.*

*Email: [info@benchchem.com](mailto:info@benchchem.com) or [Request Quote Online](#).*

## Sources

- [1. molan.wdfiles.com](http://molan.wdfiles.com) [[molan.wdfiles.com](http://molan.wdfiles.com)]
- [2. Air-Sensitive Chemistry: Practical and Safety Considerations | Fisher Scientific](https://fishersci.be) [[fishersci.be](https://fishersci.be)]
- [3. Air-free technique - Wikipedia](https://en.wikipedia.org) [[en.wikipedia.org](https://en.wikipedia.org)]
- [4. kintekfurnace.com](http://kintekfurnace.com) [[kintekfurnace.com](http://kintekfurnace.com)]
- [5. pdf.benchchem.com](http://pdf.benchchem.com) [[pdf.benchchem.com](http://pdf.benchchem.com)]
- [6. schlenklinesurvivalguide.com](http://schlenklinesurvivalguide.com) [[schlenklinesurvivalguide.com](http://schlenklinesurvivalguide.com)]
- [7. Schlenk line - Wikipedia](https://en.wikipedia.org) [[en.wikipedia.org](https://en.wikipedia.org)]
- [8. ccc.chem.pitt.edu](http://ccc.chem.pitt.edu) [[ccc.chem.pitt.edu](http://ccc.chem.pitt.edu)]
- [9. ehs.umich.edu](http://ehs.umich.edu) [[ehs.umich.edu](http://ehs.umich.edu)]
- [10. How To](http://chem.rochester.edu) [[chem.rochester.edu](http://chem.rochester.edu)]
- [11. ccc.chem.pitt.edu](http://ccc.chem.pitt.edu) [[ccc.chem.pitt.edu](http://ccc.chem.pitt.edu)]
- [12. epfl.ch](http://epfl.ch) [[epfl.ch](http://epfl.ch)]
- [13. Chemistry Teaching Labs - Degassing solvents](http://chemtl.york.ac.uk) [[chemtl.york.ac.uk](http://chemtl.york.ac.uk)]
- [14. berry.chem.wisc.edu](http://berry.chem.wisc.edu) [[berry.chem.wisc.edu](http://berry.chem.wisc.edu)]
- [15. web.mit.edu](http://web.mit.edu) [[web.mit.edu](http://web.mit.edu)]
- [16. chem.libretexts.org](http://chem.libretexts.org) [[chem.libretexts.org](http://chem.libretexts.org)]
- [17. pdf.benchchem.com](http://pdf.benchchem.com) [[pdf.benchchem.com](http://pdf.benchchem.com)]
- [18. BJOC - Synthesis of unnatural  \$\alpha\$ -amino esters using ethyl nitroacetate and condensation or cycloaddition reactions](https://beilstein-journals.org) [[beilstein-journals.org](https://beilstein-journals.org)]
- [19. chemistry.stackexchange.com](http://chemistry.stackexchange.com) [[chemistry.stackexchange.com](http://chemistry.stackexchange.com)]
- [20. drs.illinois.edu](http://drs.illinois.edu) [[drs.illinois.edu](http://drs.illinois.edu)]
- To cite this document: BenchChem. [Technical Support Center: Handling Air-Sensitive Amino Esters]. BenchChem, [2026]. [Online PDF]. Available at: [<https://www.benchchem.com/product/b3289196/docs#technical-support-center-handling-air-sensitive-amino-esters>]

---

### Disclaimer & Data Validity:

The information provided in this document is for Research Use Only (RUO) and is strictly not intended for diagnostic or therapeutic procedures. While BenchChem strives to provide accurate protocols, we make no warranties, express or implied, regarding the fitness of this product for every specific experimental setup.

**Technical Support:** The protocols provided are for reference purposes. Unsure if this reagent suits your experiment?

**Need Industrial/Bulk Grade?** [Request Custom Synthesis Quote](#)

## BenchChem

Our mission is to be the trusted global source of essential and advanced chemicals, empowering scientists and researchers to drive progress in science and industry.

### Contact

Address: 3281 E Guasti Rd  
Ontario, CA 91761, United States  
Phone: (601) 213-4426  
Email: [info@benchchem.com](mailto:info@benchchem.com)

[Contact our Ph.D. Support Team for a compatibility check](#)